

APPENDIX J

NON-CEQA INTERSECTION OPERATIONAL EVALUATION

Intersection Operational Evaluation

# Beach Cities Health District Healthy Living Campus Master Plan

Prepared for:

Wood Environment & Infrastructure Solutions, Inc.

February 2021

LB19-0004

FEHR  PEERS

# Table of Contents

---

<b>1. Introduction</b>	<b>1</b>
1.1 Project Description	1
1.2 Localized Analysis Study Scope	3
1.2.1 Study Area	3
1.2.3 Localized Analysis Scenarios	7
1.2.4 Localized Analysis Methodologies & Operational Effect Criteria	7
1.2.5 Trip Generation	7
1.2.6 Trip Distribution	10
1.2.7 Signalized Intersection Operational Effect Analysis	10
1.3 Organization of the Report	12
<b>2. Existing (2020) Conditions</b>	<b>13</b>
2.1 Existing Roadway Facilities	13
2.2 Existing Pedestrian and Bicycle Facilities	15
2.3 Existing Public Transit Facilities	16
2.4 Existing Intersection Operating Conditions	19
2.4.1 Intersection Lane Geometries	19
2.4.2 Intersection Traffic Volumes	19
2.4.3 Level of Service Methodology	19
2.4.4 Intersection Level of Service Results	21
<b>3. Cumulative (2032) Conditions</b>	<b>23</b>
3.1 Cumulative Without Project (2032) Operating Conditions	23
3.1.1 Intersection Lane Geometries	23
3.1.2 Intersection Traffic Volumes	23
3.1.3 Level of Service Methodology	23
3.1.4 Level of Service Results	24
3.1.5 Cumulative without Project Pedestrian and Bicycle Conditions	26
3.1.6 Cumulative without Project Transit Conditions	26
<b>4. Project Conditions &amp; Operational Effects Analysis</b>	<b>27</b>
4.1 Project Trip Generation	27
4.2 Project Trip Distribution	27
4.3 Cumulative Plus Project Conditions	30
4.3.1 Intersection Traffic Volumes	30

4.3.2 Level of Service Methodology .....	30
4.3.3 Level of Service Results.....	30
4.3.4 Cumulative plus Project Pedestrian and Bicycle Conditions.....	32
4.3.5 Cumulative plus Project Transit Conditions.....	32
<b>5. Summary .....</b>	<b>33</b>

## Appendices

---

- Appendix A – Trip Generation Methodologys
- Appendix B – Driveway & Pedestrian Counts
- Appendix C – Ballard\*King & Associates Aquatics Center Preliminary Market Feasibility Evaluation
- Appendix D – Peak Period Turning Movements & Lane Geometries
- Appendix E – Traffic Count Sheets
- Appendix F – Level of Service Worksheets

## List of Figures

---

Figure 1 – Project Site Plan.....	4
Figure 2 – Study Area Intersections.....	5
Figure 3 – Existing and Planned Bicycle Facilities.....	17
Figure 4 – Study Area Transit Routes.....	18
Figure 5 – Project Trip Distribution.....	29

## List of Tables

---

Table 1 – Study Area Intersections.....	6
Table 2 – Project Trip Calibration.....	9
Table 3 – Thresholds of Evaluation.....	11
Table 4 – Level of Service Definitions for Signalized Intersections – ICU Methodology.....	20
Table 5 - Level of Service Definitions for Unsignalized Intersections – HCM Methodology.....	20
Table 6 – Existing (2020) Intersection Level of Service.....	22
Table 7 – Cumulative Year (2032) Intersection Level of Service.....	25
Table 8 – Project Trip Generation.....	28

# 1. Introduction

This report documents the results of the intersection operational evaluation prepared by Fehr & Peers to evaluate the potential operational effects of the proposed Beach Cities Health District (BCHD) Healthy Living Campus Master Plan ("Project"), in the City of Redondo Beach, California, and adjacent to the City of Torrance. The report documents the methodologies and criteria used to evaluate the Project and summarizes the analysis of existing and future cumulative conditions.

Signed into law in 2013, Senate Bill (SB) 743 eliminates level of service (LOS) as a basis for determining significant transportation impacts under CEQA and provides a new performance metric – VMT. While SB 743 prohibits the use of LOS as a basis for determining significant transportation impacts under CEQA, the legislation does not preclude the application of local general plan policies, zoning codes, conditions of approval, or any other planning requirements. This report was prepared in response to requests by the Cities of Redondo Beach and Torrance to analyze the Project's effects on the local street system. Localized transportation assessments may continue to utilize LOS as a basis for assessing the effects of development projects on traffic operations. LOS analysis has been included in this report for informational and planning purposes only. The methodologies used to develop the LOS analysis are detailed below.

## 1.1 Project Description

The proposed Project would involve the long-term redevelopment of the existing BCHD campus and the adjacent vacant Flagler lot with new public health care and wellness facilities that would address the need to replace seismically vulnerable buildings on-site and expand public health programs and services offered by BCHD. The proposed redevelopment of the BCHD campus would occur in two phases of development that would demolish and replace the Beach Cities Health Center with new, purpose-built facilities on the existing campus and the vacant Flagler lot. The proposed Healthy Living Campus Master Plan presents a site development plan for Phase 1, providing the best available detail given preliminary planning efforts. Phase 2 of development would occur well into the future and is described as a program of proposed uses within a maximum envelope of development.

Phase 1 of the development would provide a 203,700-square-foot (sf) Residential Care for the Elderly (RCFE) Building with 157 new Assisted Living units, 60 replacement Memory Care units (replacing the Silverado Beach Cities Memory Care Community located within the existing Beach Cities Health Center), 14,000 sf of space for the Program of All-Inclusive Care for the Elderly (PACE), and 6,270 sf of space for Community Services. The Beach Cities Health Center would remain in place for the duration of construction of the RCFE Building to allow a majority of BCHD's existing programs to continue, and would be demolished only at the end of Phase 1. However, prior to the beginning of construction, the Center for Health and Fitness (CHF) will be temporarily relocated to an off-site location. Because a fitness center use tends to have a high parking demand, relocating the CHF would alleviate the potential for temporary parking constraints associated with the demolition of the 70,000-sf surface parking lot at the beginning of Phase 1. The primary vehicle ingress and egress would continue to be provided from the main entrance and the two secondary entrances along

North Prospect Avenue. However, once completed, the new RCFE Building would include a patient pick-up/drop-off zone within a new one-way porte-cochère driveway located on the vacant Flagler Lot as well as a subterranean service area and loading dock. The porte-cochère driveway would be accessible via a right-turn along eastbound Beryl Street, and would provide a left-turn-only exit onto Flagler Lane, immediately south of Beryl Street. A new service-only access entrance would be provided off of Flagler Lane approximately 150 feet south of Beryl Street, providing a right-turn in and left-turn out service entrance. This driveway would lead directly to the service area and loading dock beneath the RCFE Building, and would be limited to service vehicles and delivery vehicles only and would not be used by staff, residents, participants, or other visitors to the BCHD campus. Phase 1 would also include approximately 125,890 sf of open space and an approximately 36,500-sf surface parking lot with 91 parking spaces (including 6 handicap accessible parking spaces).

The ultimate buildout for Phase 2 may vary due to facility needs, funding, and market conditions. However, to assess the potential for impacts associated with Phase 2, this study assumes the maximum development within the envelope included in the proposed Healthy Living Campus Master Plan. For the purposes of the EIR evaluation to provide a reasonable worst-case assessment, Phase 2 of the development is assumed to consist of a 97,550-sf Community Health and Wellness Center with a 31,300-sf Aquatics Center (including 7,300 sf of outdoor space), a 20,000-sf Center for Health and Fitness, and a 37,150-sf Wellness Pavilion, and 9,100-sf Youth Wellness Center. The footprint of the Community Health and Wellness Center would generally be located within the surface parking lot constructed during Phase 1. Parking would be provided by a 7-story above ground parking structure with up to 739 parking spaces (including 15 accessible parking spaces). As noted above, these estimates of buildout represent the maximum end of potential future Phase 2 development.

Construction of the proposed Project would require demolition of the existing Beach Cities Health Center the associated Maintenance Building at the end of Phase 1 as well as the existing above ground parking structure at 512 North Prospect Avenue at the beginning of Phase 2. Additionally, depending on the scope of development in Phase 2, the proposed Project may involve the demolition of the 510 North Prospect Avenue building and the replacement of existing Medical Office Building (MOB) space in a new purpose-built facility. **Figure 1** illustrates the ground level site plan for the Project.

#### *1.1.1.1 Vehicular Site Access*

Vehicular access from the existing three driveways on Prospect Avenue will be maintained with the Project. These are described below:

- Full access signalized main driveway
- Right-in/right-out only south driveway
- Right-in/right-out only north driveway

Vehicular access would also be provided at two new driveways, described below:



- One right-in only driveway on Beryl Street west of Flagler Lane
- One left-out only driveway on Flagler Lane south of Beryl Street

The Project's new access locations would be designed to national, state and City of Redondo Beach and City of Torrance (where applicable) engineering standards and would provide adequate sight distance, sidewalks, crosswalks, and pedestrian movement controls that meet each City's requirements to protect pedestrian, driver, and bicyclist safety.

## 1.2 Localized Analysis Study Scope

This section details the analysis scenarios, methodologies, and operational effect criteria used to assess the Project's potential to trigger transportation operational effects. While the cities have level of service standards, the evaluation follows how the cities previously would have evaluated a project's contribution to declining operations at an intersection. This scope was prepared in accordance with the requirements of the City of Redondo Beach, and in consultation with the City of Torrance.

### 1.2.1 Study Area

In consultation with City of Redondo Beach and City of Torrance staff, the study area for the localized analysis was selected to include the intersections most likely to be affected by traffic generated by the Project. A total of 25 intersections were identified for analysis in the scenarios detailed below. These study intersections are shown in **Figure 2**. Of the study intersections, listed in **Table 1**, 21 are signalized and four are stop-controlled. AM and PM peak hour turning movement volumes were analyzed at these study intersections. Traffic intersection counts for the localized analysis were collected in January 2020 on a typical weekday when schools were in session, prior to the COVID-19 pandemic and the associated disruptions to businesses and schools and resulting changes in travel behavior.



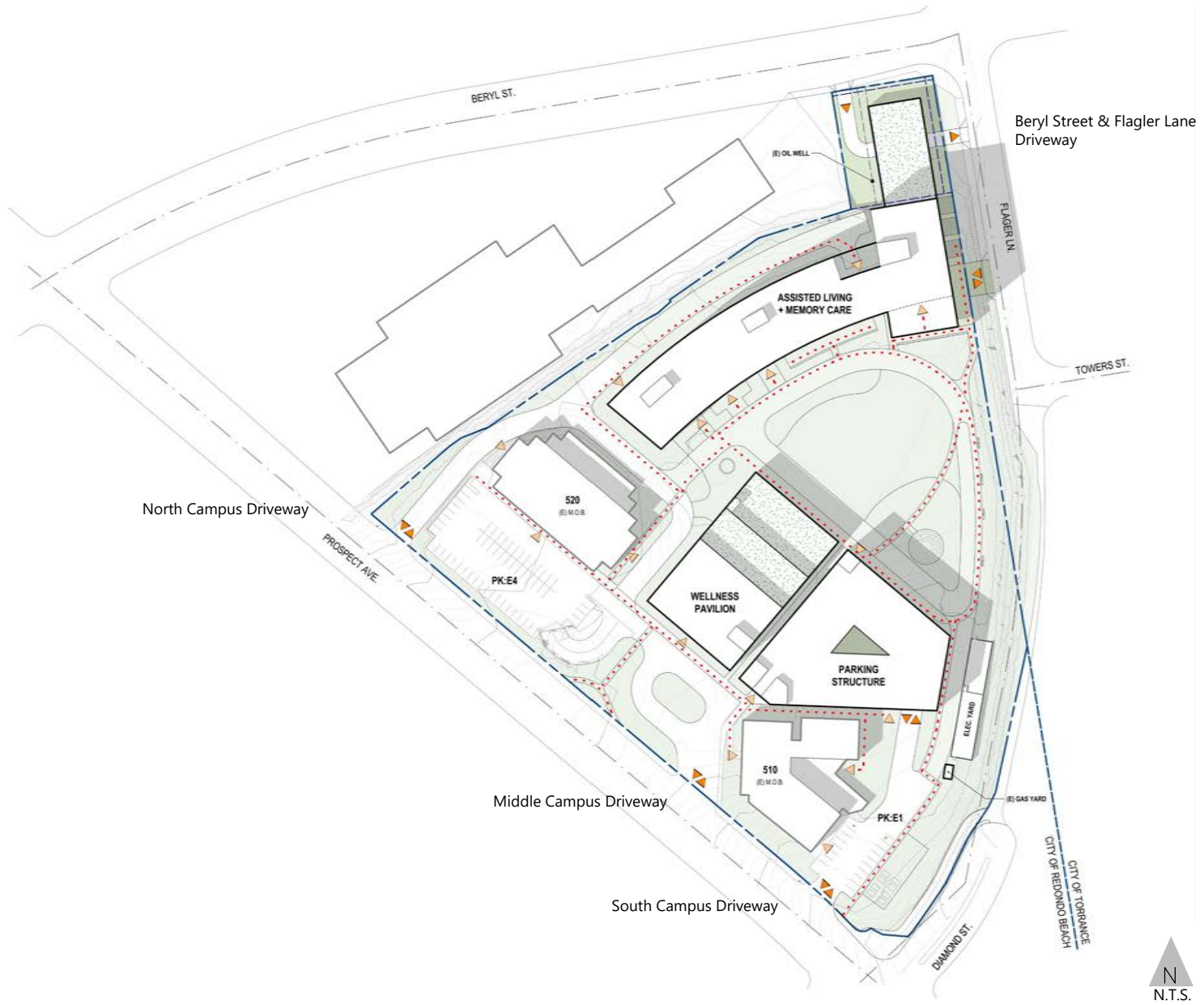
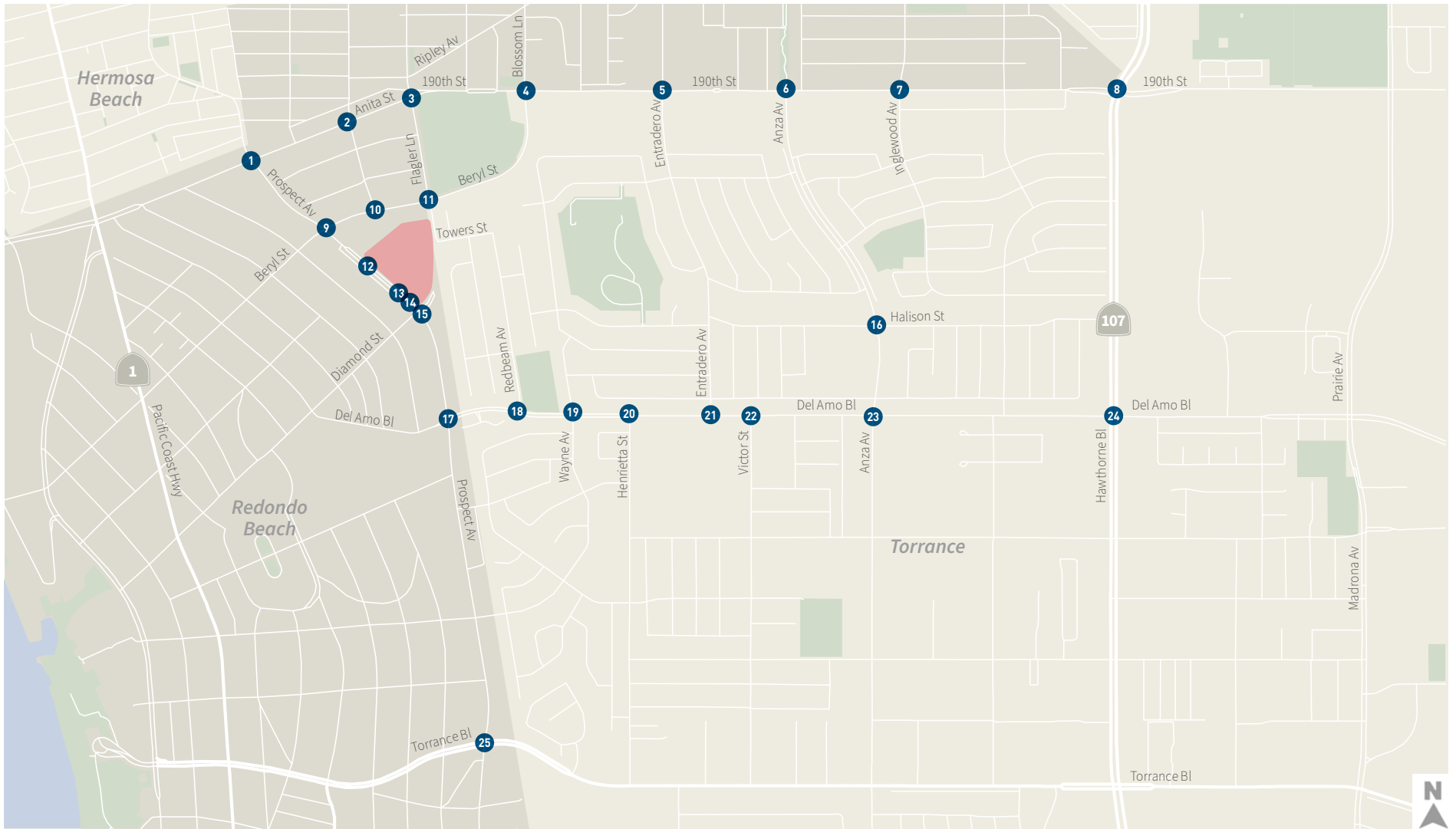

Figure 1

Ground Level Site Plan



CONCEPTUAL - NOT FOR CONSTRUCTION.



**Study Intersections**

- # Proposed Study Intersections
- ▾ Beach Cities Health District
- Ocean
- Parks



Figure 2  
Study Intersections

**Table 1 – Study Area Intersections**

ID	North-South Street Name	East-West Street Name	Jurisdiction	Control
1	Prospect Avenue	Anita Street	Redondo Beach	Signalized
2	Harkness Lane	Anita Street	Redondo Beach	Signalized
3	Flagler Lane	190 <sup>th</sup> Street	Redondo Beach	All-way stop-control
4	Beryl Street/Blossom Lane	190 <sup>th</sup> Street	Shared jurisdiction	Signalized
5	Entradero Avenue/Meyer Lane	190 <sup>th</sup> Street	Shared jurisdiction	Signalized
6	Anza Avenue	190 <sup>th</sup> Street	Shared jurisdiction	Signalized
7	Inglewood Avenue	190 <sup>th</sup> Street	Shared jurisdiction	Signalized
8	Hawthorne Boulevard	190 <sup>th</sup> Street	Shared jurisdiction	Signalized
9	Prospect Avenue	Beryl Street	Redondo Beach	Signalized
10	Harkness Lane/Parking Lot	Beryl Street	Redondo Beach	All-way stop-control
11	Flagler Lane	Beryl Street	Redondo Beach	All-way stop-control
12	Prospect Avenue	North Campus Driveway	Redondo Beach	Side-street stop-control
13	Prospect Avenue	Middle Campus Driveway	Redondo Beach	Signalized
14	Prospect Avenue	South Campus Driveway	Redondo Beach	Side-street stop-control
15	Prospect Avenue	Diamond Street	Redondo Beach	Signalized
16	Anza Avenue	Harrison Street	Torrance	Signalized
17	Prospect Avenue	Del Amo Boulevard	Redondo Beach	Signalized
18	Redbeam Avenue	Del Amo Boulevard	Torrance	Side-street stop-control
19	Wayne Avenue	Del Amo Boulevard	Torrance	Signalized
20	Henrietta Street	Del Amo Boulevard	Torrance	Signalized
21	Entradero Avenue	Del Amo Boulevard	Torrance	Signalized
22	Victor Street	Del Amo Boulevard	Torrance	Signalized
23	Anza Avenue	Del Amo Boulevard	Torrance	Signalized
24	Hawthorne Boulevard	Del Amo Boulevard	Torrance	Signalized
25	Prospect Avenue	Torrance Boulevard	Torrance	Signalized



### 1.2.3 Localized Analysis Scenarios

The scenarios described below were analyzed for this study.

#### 1.2.3.1 Baseline Conditions

- Existing (Year 2020) Conditions – The analysis of existing traffic conditions using existing counts and geometric lane configurations provides a basis for the remainder of the study and includes an assessment of the street system, traffic volumes, and operating conditions. Traffic counts were collected in January 2020, prior to the COVID-19 pandemic.
- Cumulative without Project Conditions (Year 2032) – Future traffic conditions are provided in this scenario without the proposed Project. The City of Redondo Beach assumes an annual traffic growth rate of 0.38% per year to be applied to estimate future Year 2032 traffic volumes, based on the population growth rate for the City of Redondo Beach included in the 2016 Southern California Association of Governments (SCAG) travel demand model.<sup>1</sup> The 2020 SCAG model is not yet available. The City of Torrance assumes a 0.525% growth. For intersections with shared jurisdictions, the City of Torrance’s growth rate was applied to develop the most conservative analysis. The inclusion of specific other development projects (related projects) in cumulative growth estimates was considered, however there were no significant related projects within 1-½ miles for inclusion in the forecasts. Therefore, cumulative conditions were developed only using the growth rates provided by the individual cities, as the ambient growth would be sufficient to cover expected growth.

#### 1.2.3.2 Project Conditions

- Cumulative plus Project Conditions (Year 2032) – This scenario provides the basis for the analysis of future conditions with traffic generated by the Project after Phase 2 would be completed. Project trips were assigned to the roadway network based on the trip generation and trip distribution analyses described in this report. This scenario was developed by adding Project trips to the Cumulative Conditions (2032) without Project scenario detailed above.

### 1.2.4 Localized Analysis Methodologies & Operational Effect Criteria

The following section documents the transportation analysis methodologies used to evaluate whether the Project is consistent or not with local land use standards for roadway LOS.

### 1.2.5 Trip Generation

*Trip Generation, 10<sup>th</sup> Edition* (Institute of Transportation Engineers [ITE], 2017) represents the industry standard for estimating trip generation and is based on a compilation of empirical trip generation surveys at locations throughout the country. Using ITE is a defensible approach. However, ITE always recommends utilizing local data where it is available. Based on feedback from the City of Redondo Beach and the City of Torrance, an empirical trip generation study was conducted to validate and, if necessary, calibrate ITE trip

---

<sup>1</sup> SCAG 2016 RTP/SCS is available online at: <http://scagrtpscs.net/Pages/FINAL2016RTPSCS.aspx>

generation rates to reflect site conditions on the BCHD campus. The trip generation methodology is further detailed in **Appendix A**.

A full day (24 hours) of driveway counts were collected at the Project site on a typical weekday when school was in session in October 2019 (included in this report as **Appendix B**). While driveway counts can be used for validating overall campus trip generation, they do not allow for the analysis of how trip generation rates for a particular land use at the BCHD campus vary from ITE rates. Providing more detailed trip rate validation further enhances the accuracy and defensibility of the trip rates used in this analysis, as well as allowing for the use of locally accurate trip rates by land use, so that the Project trip generation estimates accurately account for the expected trip generation with the changing mix of land uses in the Project.

In order to assess the difference by land use type, 24-hour pedestrian counts were conducted at the entrances to each building on campus on the same day as driveway counts were collected. Buildings 510 and 520 both contain exclusively Medical Office functions, so pedestrian counts at those buildings were used to develop a BCHD Medical Office trip rate to compare with ITE. Pedestrian trips to Building 514 could not be fully isolated by land use due to the mix of land uses contained therein. However, because the Childcare Center has a dedicated entrances to the building, that use could be isolated and compared with ITE. Membership scans of the Center for Health and Fitness were used to estimate trips to that use. The remaining Building 514 uses (Assisted Living, College, General Office), cannot be individually compared with the ITE rate, but could be compared collectively, as described below in the discussion of the calibration process. Pedestrian counts are included in this report in **Appendix B**.

#### *1.2.5.1 Trip Generation Rate Calibration*

**Table 2** presents the trip calibration for the proposed Project. For the existing campus, ITE rates were applied to each specific land use based on the existing occupied space. Using ITE rates, the BCHD campus is currently estimated to generate 5,854 daily trips, 530 AM peak hour trips, and 637 PM peak hour trips. **Table 2** also presents the ITE trip generation estimates by building and the land uses that were isolatable, compared with the actual collected counts. As counted during 2019 on-site surveys, the existing BCHD campus generated 6,713 daily trips, 610 AM peak hour trips, and 455 PM peak hour trips. Compared with ITE estimates, the campus generates 15% more daily, 15% more AM peak hour trips, and 29% fewer PM peak hour trips. Most of the isolatable land uses in the count study show a similar trend of generating more trips than would be expected using ITE trip rate estimates, with the exception of the Childcare Center, which generated fewer trips compared with ITE across all time periods.

A combined calibration factor for the non-isolated uses at Building 514 was calculated by deducting the trips to the building destined for the Center for Health & Fitness and the Childcare Center from the total and calculating a factor with the remaining trips.



**Table 2  
Project Trip Calibration**

Land Use	Existing Occupied Land Use	ITE Rates							ITE Trip Generation							Collected Counts			Calibration Rate		
		Daily	AM Peak Hour			PM Peak Hour			Daily	AM Peak Hour			PM Peak Hour			Daily	AM Peak Hour	PM Peak Hour	Daily	AM Peak Hour	PM Peak Hour
			In	Out	Total	In	Out	Total		In	Out	Total	In	Out	Total						
<b>Existing Uses To Be Removed</b>																					
Building 514 - Child Care Center [c]	9.717 ksf gfa	47.62	53%	47%	11.00	47%	53%	11.12	463	57	50	107	51	57	108	384	91	63	0.829	0.850	0.583
Building 514 - Medical Office [c]	42.103 ksf gfa	34.80	78%	22%	2.78	28%	72%	3.46	1,465	91	26	117	41	105	146	1,556	137	106	1.062	1.167	0.726
Building 514 - Center for Health & Fitness [c]	12.294 ksf gfa	28.82	66%	34%	1.76	47%	53%	2.31	354	15	7	22	13	15	28	797	64	42	2.251	2.909	1.500
Building 514 (Other - Not isolatable)									497			44			52	547	17	11	1.101	0.386	0.212
Building 514 - Memory Care	120 beds	2.60	63%	37%	0.19	38%	62%	0.26	312	14	9	23	12	19	31				1.101	0.386	0.212
Building 514 - College [c]	1.519 ksf gfa	20.25	77%	23%	2.07	50%	50%	1.86	31	2	1	3	1	2	3				1.101	0.386	0.212
Building 514 - General Office [c]	15.810 ksf gfa	9.74	86%	14%	1.16	16%	84%	1.15	154	15	3	18	3	15	18				1.101	0.386	0.212
<b>Subtotal Existing to be Removed</b>									2,779			290			334	3,284	309	222			
<b>Existing Uses Remaining</b>																					
Building 510 - Medical Office [a]	45.913 ksf gfa	34.80	78%	22%	2.78	28%	72%	3.46	1,598	100	28	128	45	114	159				1.062	1.167	0.726
Building 520 - Medical Office [b]	46.881 ksf gfa	34.80	78%	22%	2.78	28%	72%	3.46	1,631	101	29	130	45	117	162				1.062	1.167	0.726
<b>Subtotal Existing to Remain</b>	92.794 ksf gfa	34.80	78%	22%	2.78	28%	72%	3.46	3,229			258			321	3,429	301	233	1.062	1.167	0.726
<b>TOTAL TRIP GENERATION</b>									<b>5,854</b>	<b>380</b>	<b>150</b>	<b>530</b>	<b>208</b>	<b>429</b>	<b>637</b>	<b>6,713</b>	<b>610</b>	<b>455</b>	<b>1.147</b>	<b>1.151</b>	<b>0.714</b>

Notes

[a] Bldg 510 is 51,500 SF GFA. At time of counts 4,998 SF of GLA space was vacant, which is an estimated 5,587 SF of GFA. This has been deducted from the space to reflect the occupied space at the time of the driveway counts.

[b] Bldg 520 is 47,700 SF GFA. At time of counts 815 SF of GLA space was vacant, which is an estimated 819 SF of GFA. This has been deducted from the space to reflect the occupied space at the time of the driveway counts.

[c] Bldg 514 is 157,681 SF GFA, and 132,900 SF of GLA (excluding 4,224 SF of outdoor child care area). At time of counts 13,044 SF of GLA was vacant, which is an estimated 15,476 SF of GFA. This has been deducted from the space to reflect occupied space at the time of the driveway counts. Land uses presented as GFA were estimated by applying overall bldg ratio of GFA to GLA.

### *1.2.5.2 Phased Trip Generation Estimates*

The calibrated trip rates from **Table 2** were applied to a trip generation analysis by phase for each of the two proposed phases. The phased analyses include estimated trip generation for the proposed land uses that would be added, with the trip generation of the existing uses to be removed. Chapter 5 presents the trip generation estimates for the proposed Project.

### **1.2.6 Trip Distribution**

Fehr & Peers obtained origin-destination data for the existing BCHD site using StreetLight data location-based service (LBS) data. StreetLight is a “big data” vendor that aggregates and summarizes origin/destination data using cell phone and app location-based data (such as Google Maps) to quantify and measure the travel patterns for a site using the travel patterns of unique cellular devices (these data are aggregated into grid cells to maintain individual user privacy). Fehr & Peers input BCHD’s campus into the Streetlight portal and mapped the relative weight of the origin/destination grid cells to/from the campus. The resulting analysis was used to inform trip distribution from the site.

In addition to the information gleaned from the StreetLight analysis, Fehr & Peers also considered the effects on distribution at the intersections immediately adjacent to the Project site of the new Project driveways into and out of the subterranean parking facility on the northeast corner of the campus. A new driveway on Beryl Street would provide right-turn-only ingress into the Project site, while a driveway on Flagler Lane would provide left-turn-only egress. These new driveways will generally not be used by the majority of visitors to the site, who will find the existing driveways on Prospect Avenue to be the most direct access to parking that serves the medical office, Center for Health and Fitness, and the Aquatics Center, among other patient/visitor focused uses. The Beryl Street driveway would primarily serve memory care and assisted living residents and PACE participants. It is expected that a certain portion of residents of the assisted living facility and participants at PACE would use the Beryl Street driveway, while employees will likely continue to use the Prospect Avenue driveways. However, since trip generation estimates do not disaggregate trips to assisted living facilities by user (resident, visitor, employee), 100% of assisted living trips were assigned to the Beryl driveway. This represents the most conservative approach, as the assisted living use is the highest trip generator of any proposed land use.

Based on the results of the StreetLight analysis, Fehr & Peers developed a trip distribution pattern for the Project. **Figure 5** in Chapter 5 shows the trip distribution for the Project.

### **1.2.7 Signalized Intersection Operational Effect Analysis**

#### *1.2.7.1 Analysis Methodology*

Consistent with City of Redondo Beach and City of Torrance requirements, signalized study intersections were analyzed using the Intersection Capacity Utilization (ICU) methodology. The ICU methodology is used to determine the intersection V/C ratio and corresponding level of service (LOS) for the turning movements and intersection characteristics at signalized intersections. The ICU value is calculated by summing the V/C



ratio sum of the critical movements, plus a factor for yellow signal time. AM and PM peak hour ICU ratios and levels of service (LOS) were calculated using the Fehr & Peers' ICU spreadsheet tool. Lane capacity assumptions do not exceed 1,600 vehicles per lane per hour. This methodology addresses operational effects on all motor vehicles utilizing City of Redondo Beach and City of Torrance roadways, including transit vehicles. The four stop-controlled intersections were analyzed using the Highway Capacity Manual (HCM) method. For side-street stop-controlled intersections, the HCM unsignalized methodology assesses available and critical gaps in the traffic stream on the major street which allow for side street traffic to enter the major street flow, particularly for left-turn movements which require the greatest gap in traffic, and reports the worst-case approach delay (i.e., the approach with the longest delay). For all-way stop-controlled intersections, the average approach delay experienced by all vehicles passing through the intersection is reported. The Synchro software was used to calculate peak hour intersection delay and LOS at unsignalized intersections.

#### 1.2.7.1.1 Standards for Intersection Operational Evaluation – City of Redondo Beach

**Table 3** details standards for evaluation of the incremental increase in ICU ratio were used to assess transportation operational effects at the signalized study intersections. The level of effect of the Project's incremental increase in the ICU ratio is dependent upon the underlying LOS value for that specific peak hour based on the thresholds in the table.

**Table 3 – Thresholds of Evaluation**

Intersection LOS Under Without Project Conditions	Change in Volume to Capacity (Future w/Project less Future w/o Project)
A	----
B	----
C	0.040
D	0.020
E	0.010
F	0.010

Source: City of Redondo Beach Circulation Element, 2008

#### 1.2.7.1.2 Standards for Intersection Operational Evaluation – City of Torrance

The following thresholds of evaluation for the incremental increase in ICU ratio were used to assess whether substantial operational effects occur as the result of Project implementation at the signalized study intersections, based on input from City of Torrance staff. The level of effect of the Project's incremental increase in the ICU ratio is dependent upon the underlying LOS value for that specific peak hour based on the following thresholds:



- Based on the ICU analysis, a substantial operational effect would occur when the Project causes a change from LOS D or better to LOS E or F.
- If the Project increases traffic at the intersection by 2% of capacity (ICU increase  $\geq 0.020$ ), causing or worsening LOS E or F (ICU  $> 0.901$ ), it would be classified as a substantial operational effect.
- Based on the HCM analysis, a substantial operational effect would be identified when the Project causes a change from LOS D or better to LOS E or F, or the Project causes an increase in delay of 2% or more at an intersection operating LOS E or F.

### **1.3 Organization of the Report**

This report is divided into five chapters, including this introduction. Chapter 2 introduces the localized analysis and documents Existing Conditions in the study area. Chapter 3 describes the methodologies used to develop traffic forecasts for the Cumulative (2032) Without Project scenario and assesses Cumulative operating conditions. Chapter 4 summarizes the methodologies to forecast Project conditions and includes an assessment of the Project's potential transportation operational effects compared with the existing and cumulative baseline scenarios. Chapter 5 summarizes the results of the study.



## 2. Existing (2020) Conditions

This chapter details the comprehensive data collection and analysis effort undertaken to assess Existing Conditions in the study area.

### 2.1 Existing Roadway Facilities

The street network in the City of Redondo Beach is primarily gridded with good connectivity. Arterial streets in the study area generally provide two to three vehicle travel lanes in each direction, with left-turn pockets at most intersections and right-turn pockets at some intersections. Posted travel speeds in the study area range from 35 to 50 miles per hour (mph), with the majority of streets allowing travel up to 35 mph. As described in detail below, regional access to the Project site is provided by the Pacific Coast Highway (PCH) and a network of arterial and collector streets. The arterial street network that serves the proposed Project area includes 190th Street, Anita Street, Anza Avenue, Beryl Street, Del Amo Boulevard, Hawthorne Boulevard, Inglewood Avenue, Prospect Avenue, and Torrance Boulevard. The local streets include Blossom Lane, Diamond Street, Harkness Lane, Entradero Avenue, Flagler Lane, Halison Avenue, Henrietta Street, Redbeam Avenue, and Wayne Avenue. The following describes the key roadway facilities that serve the Project site:

The following details the key roadway facilities that serve the Project site:

- Pacific Coast Highway (State Route 1) - PCH is a 4-lane north/south major arterial. Left-turn lanes are provided at major intersections. On-street parking is prohibited along sections of PCH at Torrance Boulevard, Catalina Avenue and Diamond Street, and generally permitted elsewhere. As a state route, PCH is under the jurisdiction of Caltrans.
- 190th Street – 190th Street is an east/west major arterial that runs east from Flagler Lane following the transition from Anita Street. The roadway provides two lanes in each direction. There are left-turn pockets at most intersections. On-street parking is generally allowed on the north side of the street, except between Rindge Lane and Phelan Avenue. On the south side of the street, on-street parking is generally prohibited west of Entradero Avenue. West of Flagler Lane, 190th Street transitions to become Anita Street.
- Anita Street - Anita Street is an east/west major arterial that runs east of PCH with two lanes in each direction. Between Maria and Prospect Avenue, it has a center turning lane. East of Prospect, there are left-turn pockets at most intersections, with a raised median. On-street parking is generally permitted on both sides of Anita Street. Anita Street becomes 190th Street at the intersection with Flagler Lane.
- Anza Avenue – Anza Avenue is a north/south secondary arterial that runs from 190th Street south to PCH. Within the study area, Anza Avenue provides two lanes in each direction. Left-turn pockets are provided at most intersections. On-street parking is prohibited. However, between Arvada

Street and the junction with Halison Street, a service road is provided on the east side of the street, separated by a raised median, and on-street parking is allowed on the service road.

- Beryl Street - Beryl Street is an east/west secondary arterial that runs from Harbor Drive to 190th Street. Between Prospect Street and Catalina Avenue, Beryl Street has one lane in each direction with a center turning lane. Beryl Street narrows to two lanes east of Flagler Lane. On-street parking is permitted between Catalina Avenue and Flagler Lane.
- Blossom Lane – Blossom Lane is a local street that runs north/south from 190th Street to Manhattan Beach Boulevard. South of 190th Street, Blossom Lane transitions to become Beryl Street. The roadway provides one travel lane in each direction. On-street parking is generally allowed on both sides of the street.
- Del Amo Boulevard – Del Amo Boulevard is an east/west major arterial that runs from Diamond Street on the western end to the City of Cerritos in the east. From Diamond Street to Prospect Avenue, one travel lane is provided in each direction. East of Prospect Avenue, two travel lanes in each direction are provided and a raised center median is provided in places. Between Diamond Street and Prospect Avenue, on-street parking is permitted on the north side of the street only. East of Prospect Avenue, on-street parking is only allowed for a brief stretch on south side of the street from Donora Avenue to the bike lane transition west of the intersection with Anza Avenue, and is otherwise prohibited.
- Diamond Street – Diamond Street is an east/west collector street that runs from Catalina Avenue to Prospect Avenue, culminating in a cul-de-sac east of Prospect Avenue. This street provides one travel lane in each direction with a two-way left-turn lane. On-street parking is provided on both sides of the street.
- Entradero Avenue – Entradero Avenue is a north/south collector street that runs from 190th Street to Del Amo Boulevard and provides one travel lane in each direction. On-street parking is generally allowed on both sides of the street.
- Flagler Lane – Flagler Lane is a north/south collector street that runs from Towers Street to Artesia Boulevard and provides one travel lane in each direction. On-street parking is generally allowed on both sides of the street.
- Halison Street – Halison Street is an east/west local street that runs from Linda Street to Hawthorne Boulevard and provides one travel lane in each direction. On-street parking is generally allowed on both sides of the street.
- Hawthorne Boulevard – Hawthorne Boulevard is north/south major arterial that provides four travel lanes in each direction. A raised median separates opposing traffic. Left-turn lanes are provided at most intersections. On-street parking is prohibited within the study area.
- Henrietta Street – Henrietta Street is a north/south connector street that runs from Del Amo Boulevard to Torrance Boulevard and provides one travel lane in each direction. On-street parking is generally allowed on both sides of the street.



- Inglewood Avenue – is a north/south major arterial that provides two travel lanes in each direction north of 190th Street. South of 190th Street, the roadway transitions to a local road providing one travel lane in each direction. On-street parking is permitted north and south of 190th Street.
- Prospect Avenue – Prospect Avenue is a north/south secondary arterial that runs from Artesia Boulevard to PCH. Within the study area, it provides two travel lanes in each direction. Left-turn lanes are provided at most intersections. On-street parking is prohibited but is facilitated by the presence of a service road on which on-street parking is permitted located to the west of the main roadway, separated by a raised median.
- Redbeam Avenue – Redbeam Avenue is a north/south local street that runs from Towers Street to Del Amo Boulevard and provides one travel lane in each direction. On-street parking is generally allowed on both sides of the street.
- Torrance Boulevard – Torrance Boulevard is an east/west major arterial that provides two travel lanes in each direction west of Anza Avenue and three travel lanes in each direction east of Anza Avenue. A raised median is present from Prospect Avenue to Wendy Drive. Left-turn lanes are provided at most intersections. On-street parking is permitted on both sides of the street between Henrietta Street and Anza Avenue.
- Wayne Avenue – Wayne Avenue is a north/south local street that runs from Norton Street to Edgemere Drive and provides one travel lane in each direction. On-street parking is generally allowed on both sides of the street.

## 2.2 Existing Pedestrian and Bicycle Facilities

Sidewalks are generally present throughout the study area, and marked crosswalks are provided at all major arterial intersections. Most signalized intersections of major arterials and collector streets in the study area provide marked crossings on all four legs of the intersection, while some do not provide crossing facilities on all four legs of the intersection. Pedestrian access to the Project site is provided via a sidewalk on Prospect Avenue, with marked crosswalks provided at the intersection of Prospect Avenue & Diamond Street and Prospect Avenue & Beryl Street.

Within a half-mile radius of the Project site, existing Class II bicycle lanes are available on Beryl Street between Flagler Lane and 190th Street, Anza Avenue between 190<sup>th</sup> Street and Del Amo Boulevard, and Diamond Street between Prospect Avenue and North Catalina Avenue. An existing Class III bicycle route is available on Flagler Lane, heading north from Beryl Street. There are no existing Class I bicycle paths or Class IV separated bikeways within the study area. The nearest existing bicycle access to the Project site is provided via the Class II bicycle lanes on Diamond Street and Beryl Street, but there are no existing facilities which provide direct access. The South Bay Bicycle Master Plan indicates that additional Class I, II, and III facilities are planned throughout the study area. Existing and planned bicycle facilities are presented in **Figure 3**. LOS standards do not exist for bicycle or pedestrian facilities in either city.

## 2.3 Existing Public Transit Facilities

The study area is served by several bus routes operated by three transit operators, including the Los Angeles County Metropolitan Transportation Authority (Metro), Beach Cities Transit (BCT), and Torrance Transit (TT). LOS standards do not exist for transit service in either city. **Figure 4** illustrates transit routes in the study area. The following details each individual line that serves the study area:

- Metro Line 344 - Metro Line 344 provides limited service between the Harbor Gateway Transit Center and Rancho Palos Verdes. In the study area, Line 344 travels north/south along Hawthorne Boulevard. Service is provided seven days per week, with weekday peak period headways of approximately 20 to 30 minutes.
- BCT Line 102 - BCT Line 102 provides local service between the Metro Green Line, the South Bay Galleria, and the Redondo Beach Pier. In the study area, Line 102 travels north and south along Prospect Avenue and northeast and southwest along Beryl Street. Service is provided seven days per week, with weekday peak period headways of approximately 30 to 45 minutes.
- TT Line 2 - TT Line 2 provides local service between the Del Amo Fashion Center and the Harbor Freeway. In the study area, Line 3 travels east and west along Torrance Boulevard and north/south along Inglewood Avenue. Service is provided seven days per week, with weekday peak period headways of approximately 60 minutes.
- TT Line 3 - TT Line 3 provides rapid service between Downtown Long Beach and the Redondo Beach Pier. In the study area, Line 3 travels east/west along Torrance Boulevard. Service is provided seven days per week, with weekday peak period headways of approximately 10 to 15 minutes.
- TT Line R3 - TT Line R3 provides local service between Downtown Long Beach and the South Bay Galleria. In the study area, Line 3 travels north/south along Hawthorne Boulevard. Service is provided seven days per week. Westbound headways in the AM peak hour are approximately 6 – 15 minutes, and 25 minutes in the PM peak hour. Eastbound headways are approximately 45 – 55 minutes in the AM peak hour and 20 – 25 minutes in the PM peak hour.
- TT Line 8 - Line 8 provides local service between Torrance and the LAX Transit Center. In the study area, Line 8 travels north/south along Hawthorne Boulevard. Service is provided seven days per week, with weekday peak period headways of approximately 20 - 30 minutes.



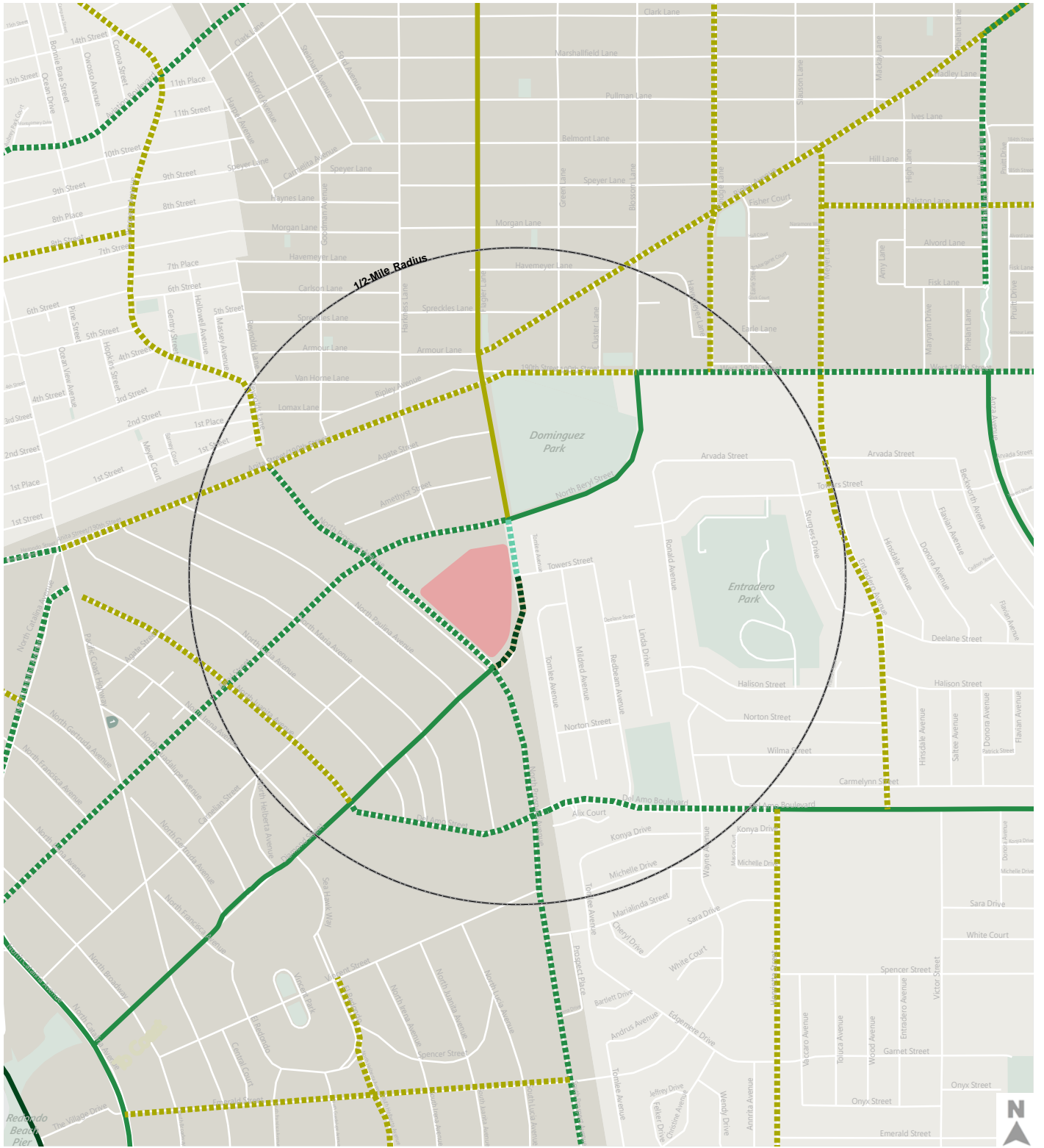

Proposed Bicycle Facilities

- Class I
- Class II
- Class III
- Class IV

Existing Bicycle Facilities

- Class I
- Class II
- Class III
- Beach Cities Health District

Figure 3

Existing & Proposed Bicycle Facilities

Source: The South Bay Bicycle Master Plan, 2011



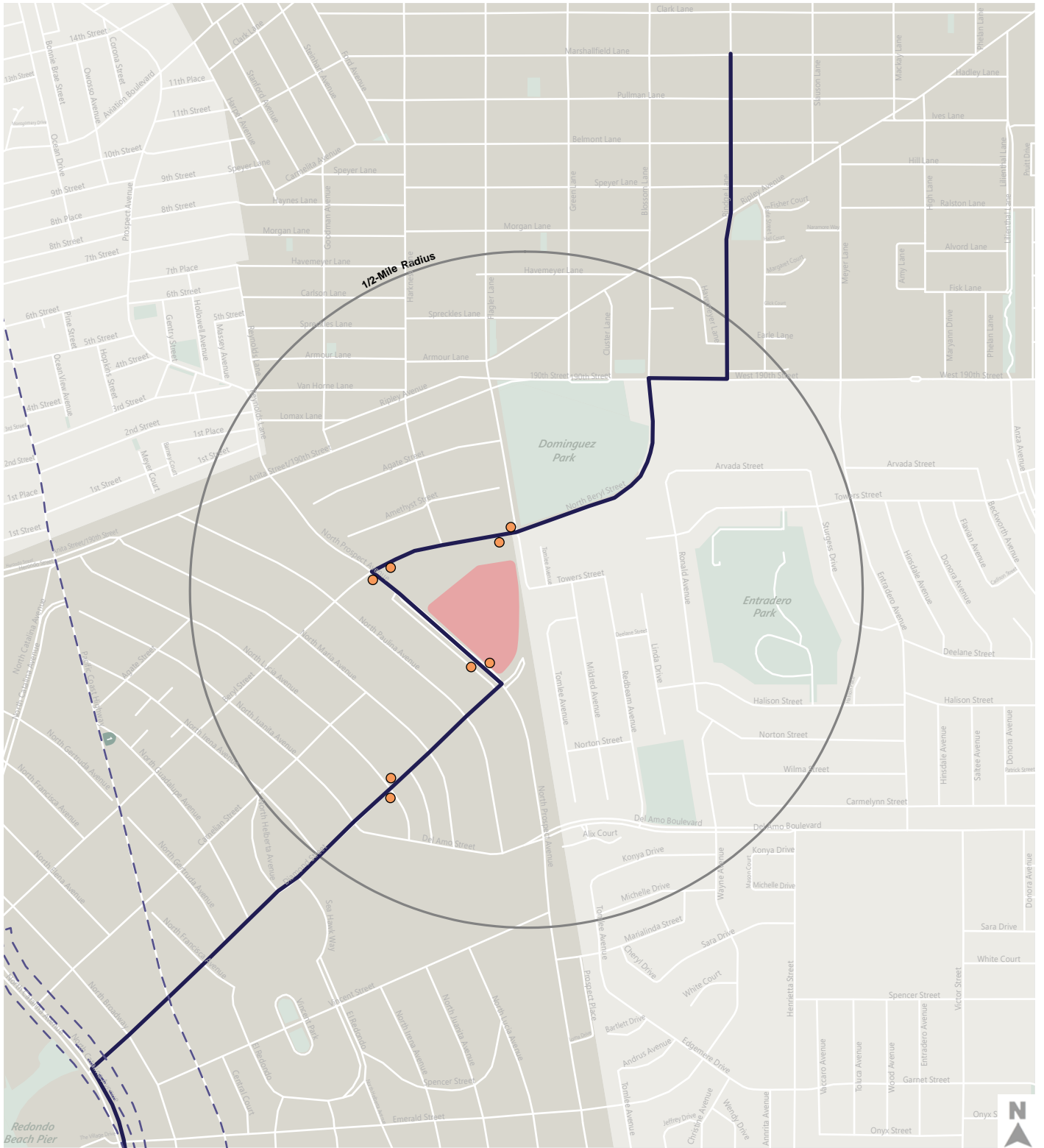

- 102 Bus Route
- Nearby Transit Routes
- Bus Stops
- Beach Cities Health District



Figure 4

## Existing Transit Facilities

## 2.4 Existing Intersection Operating Conditions

This section details existing intersection operating conditions, including the peak hour turning movement traffic volumes developed for the intersections analyzed in the study, as well as the resulting operating conditions at each intersection, analyzed by the calculation of volume-to-capacity (V/C) ratios, and the corresponding LOS.

### 2.4.1 Intersection Lane Geometries

A detailed field review of each study intersection was conducted to document the existing geometric lane configurations to be used as input to the LOS analysis.

### 2.4.2 Intersection Traffic Volumes

To analyze Existing Conditions, weekday morning and afternoon peak period intersection turning movement counts were conducted at the study intersections in January 2020. The maximum peak hour traffic volumes for each intersection from the combined data sets were selected to reflect peak volumes at each intersection, regardless of the season.

Peak hour turning movement volumes, as well as intersection lane configurations are included in **Appendix D**. Traffic count data sheets are provided in **Appendix E**.

### 2.4.3 Level of Service Methodology

LOS is a qualitative measure used to describe the condition of traffic flow on the street system, ranging from excellent conditions at LOS A to overloaded conditions at LOS F. Of the 25 study intersections, 21 are signalized. As described in Chapter 1, the Intersection Capacity Utilization (ICU) methodology was used to analyze signalized intersections. LOS definitions for the ICU methodology are provided in **Table 4**, and for the HCM methodology in **Table 5**.

The ICU method of intersection analysis was used to determine the intersection V/C ratio and corresponding LOS for the turning movements and intersection characteristics. The ICU value is determined by summing the V/C ratio sum of the critical movements, plus a factor for yellow signal time.



**Table 4 – Level of Service Definitions for Signalized Intersections – ICU Methodology**

Level of Service	Intersection Capacity Utilization (ICU)	Definition
A	0.000-0.600	<b>EXCELLENT.</b> No vehicle waits longer than one red light and no approach phase is fully used.
B	0.601-0.700	<b>VERY GOOD.</b> An occasional approach phase is fully utilized; many drivers begin to feel somewhat restricted within groups of vehicles.
C	0.701-0.800	<b>GOOD.</b> Occasionally drivers may have to wait through more than one red light; backups may develop behind turning vehicles.
D	0.801-0.900	<b>FAIR.</b> Delays may be substantial during portions of the rush hours, but enough lower volume periods occur to permit clearing of developing lines, preventing excessive backups.
E	0.901-1.000	<b>POOR.</b> Represents the most vehicles intersection approaches can accommodate; may be long lines of waiting vehicles through several signal cycles.
F	> 1.000	<b>FAILURE.</b> Backups from nearby locations or on cross streets may restrict or prevent movement of vehicles out of the intersection approaches. Tremendous delays with continuously increasing queue lengths.

Source: Adapted from Transportation Research Board

The HCM method for unsignalized intersection analysis was used to determine the vehicle delay (in seconds) and corresponding LOS for the turning movements and intersection characteristics.

**Table 5 - Level of Service Definitions for Unsignalized Intersections – HCM Methodology**

Level of Service	Description	Average Control Delay Per Vehicle (Seconds)
A	Little or no delay.	≤ 10.0
B	Short traffic delay.	> 10.0 and ≤ 15.0
C	Average traffic delays.	> 15.0 and ≤ 25.0
D	Long traffic delays.	> 25.0 and ≤ 35.0
E	Very long traffic delays.	> 35.0 and ≤ 50.0
F	Extreme traffic delays with intersection capacity exceeded.	> 50.0

Source: *Highway Capacity Manual*, Transportation Research Board, 2010.



#### 2.4.4 Intersection Level of Service Results

The existing peak hour traffic volumes shown in **Appendix D** were analyzed using the ICU methodology described above to determine the existing operating conditions at the 19 signalized intersections selected for analysis and using the HCM methodology at the six stop-controlled intersections. LOS calculation worksheets are included in **Appendix F**.

**Table 6** summarizes the results of the AM and PM peak hour intersection analysis. As shown in **Table 6**, the following six intersections operate at LOS E or F during the AM and PM peak hour under Existing Conditions. All other intersections currently operate at LOS D or better during both peak hours.

- (3) Flagler Lane & 190<sup>th</sup> Street (AM & PM peak hour)
- (10) Harkness Lane & Beryl Street (AM & PM peak hour)
- (11) Flagler Lane & Beryl Street (AM & PM peak hour)
- (18) Redbeam Avenue & Del Amo Boulevard (AM peak hour)
- (23) Anza Avenue & Del Amo Boulevard (PM peak hour)
- (24) Hawthorne Boulevard & Del Amo Boulevard (PM peak hour)

**Table 6 - Existing (2020) Intersection Levels of Service**

No.	Intersection	Control Type [a]	Peak Hour	Existing (2020)	
				V/C or Delay (Secs)	LOS
1	Prospect Av & Anita St	Signalized	AM	0.652	B
			PM	0.645	B
2	Harkness Ln & Anita St	Signalized	AM	0.637	B
			PM	0.490	A
3	Flagler Ln & 190th St	AWSC	AM	122.0	F
			PM	80.9	F
4	Beryl St/Blossom Ln & 190th St	Signalized	AM	0.719	C
			PM	0.775	C
5	Entradero Av/Meyer Ln & 190th St	Signalized	AM	0.770	C
			PM	0.716	C
6	Anza Av & 190th St	Signalized	AM	0.791	C
			PM	0.833	D
7	Inglewood Av & 190th St	Signalized	AM	0.751	C
			PM	0.856	D
8	Hawthorne Bl & 190th St	Signalized	AM	0.819	D
			PM	0.813	D
9	Prospect Av & Beryl St	Signalized	AM	0.798	C
			PM	0.686	B
10	Harkness Ln/Parking Lot & Beryl St	AWSC	AM	106.4	F
			PM	46.4	E
11	Flagler Ln & Beryl St	AWSC	AM	91.7	F
			PM	45.3	E
12	Prospect Av & North BCHD Driveway	TWSC	AM	14.6	B
			PM	12.2	B
13	Prospect Av & Middle BCHD Driveway	Signalized	AM	0.769	C
			PM	0.482	A
14	Prospect Av & South BCHD Driveway	TWSC	AM	16.0	C
			PM	11.6	B
15	Prospect Av & Diamond St	Signalized	AM	0.515	A
			PM	0.474	A
16	Anza Av & Hallison St	Signalized	AM	0.576	A
			PM	0.567	A
17	Prospect Av & Del Amo Bl	Signalized	AM	0.813	D
			PM	0.774	C
18	Redbeam Av & Del Amo Bl	TWSC	AM	69.7	F
			PM	32.3	D
19	Wayne Av & Del Amo Bl	Signalized	AM	0.446	A
			PM	0.392	A
20	Henrietta St & Del Amo Bl	Signalized	AM	0.508	A
			PM	0.468	A
21	Entradero Av & Del Amo Bl	Signalized	AM	0.685	B
			PM	0.526	A
22	Victor St & Del Amo Bl	Signalized	AM	0.543	A
			PM	0.433	A
23	Anza Av & Del Amo Bl	Signalized	AM	0.765	C
			PM	0.921	E
24	Hawthorne Bl & Del Amo Bl	Signalized	AM	0.883	D
			PM	0.915	E
25	Prospect Av & Torrance Bl	Signalized	AM	0.706	C
			PM	0.718	C

Notes: [a] TWSC = Two-Way Stop Controlled, AWSC = All-Way Stop Controlled

[b] Signalized intersections were analyzed using ICU methodology.

[c] Unsignalized intersections were analyzed using HCM methodology. The worst performing approach was reported for TWSC intersections.

# 3. Cumulative (2032) Conditions

This chapter details the traffic volume forecasts prepared to evaluate cumulative conditions, and the resulting forecasted cumulative operating conditions.

## 3.1 Cumulative Without Project (2032) Operating Conditions

### 3.1.1 Intersection Lane Geometries

Study intersections are generally expected to remain consistent with their existing lane geometries under the Cumulative (2032) without Project scenario with the exception of the following intersections, which would be modified to accommodate a proposed bicycle facility on Beryl Street:

- (10) Harkness Lane & Beryl Street – Restripe the eastbound approach to provide 1 left turn only lane and one through right lane
- (11) Flagler Lane & Beryl Street– Restripe eastbound approach to provide 1 left turn only lane and one through right lane

The City of Torrance is pursuing a pilot project that would close Flagler Lane to southbound through traffic south of Beryl Street. It is not known whether the project will be made permanent once the pilot is completed, so this analysis does not assume this lane geometry change since that results in a more conservative analysis. If that project is ultimately implemented, the future of level of service at Intersection 11 would be improved from what is estimated in this analysis.

### 3.1.2 Intersection Traffic Volumes

To estimate Cumulative (2032) without Project traffic volumes, the Existing (2020) traffic volumes for intersections located wholly within the City of Redondo Beach were increased using the SCAG population growth rate of 0.38% per year, for a total of 4.7% growth over 12 years. For intersections located wholly within the City of Torrance, the City of Torrance’s established growth rate of 0.525% per year was applied, for a total growth of 6.5% over 12 years. To provide the most conservative analysis, for intersections located on the border between the two cities, the City of Torrance’s higher growth rate was applied. CEQA typically allows a public agency to rely upon growth projections and/or a list of projects for assessing cumulative impacts. As described in Chapter 1, in addition to forecasted growth projections, the City also considered incorporating related projects planned near the proposed Project to produce a highly conservative cumulative analysis. However, no significant related projects are planned within an applicable distance. Therefore, the analysis of cumulative traffic volumes is based solely on growth projections in the study area. Cumulative without Project AM and PM peak hour traffic volumes are illustrated in **Appendix D**.

### 3.1.3 Level of Service Methodology

The AM and PM peak hour Cumulative (2032) without Project traffic volumes and intersection lane geometries were analyzed using the applicable ICU or HCM methodologies documented above.

### 3.1.4 Level of Service Results

As shown in **Table 7**, of the 25 study area intersections, seven intersections are projected to operate at LOS E or worse during one or both peak hours:

- (3) Flagler Lane & 190<sup>th</sup> Street (AM & PM peak hour)
- (7) Inglewood Avenue & 190<sup>th</sup> Street (PM peak hour)
- (10) Harkness Lane & Beryl Street (AM & PM peak hour)
- (11) Flagler Lane & Beryl Street (AM & PM peak hour)
- (18) Redbeam Avenue & Del Amo Boulevard (AM & PM peak hour)
- (23) Anza Avenue & Del Amo Boulevard (PM peak hour)
- (24) Hawthorne Boulevard & Del Amo Boulevard (AM & PM peak hour)



**Table 7 - Cumulative Year (2032) Intersection Levels of Service**

No.	Intersection	Control Type [a]	Peak Hour	Cumulative (2032) Baseline	
				V/C or Delay	LOS
1	Prospect Av & Anita St	Signalized	AM	0.677	B
			PM	0.671	B
2	Harkness Ln & Anita St	Signalized	AM	0.661	B
			PM	0.508	A
3	Flagler Ln & 190th St	AWSC	AM	143.0	F
			PM	82.0	F
4	Beryl St/Blossom Ln & 190th St	Signalized	AM	0.760	C
			PM	0.818	D
5	Entradero Av/Meyer Ln & 190th St	Signalized	AM	0.814	D
			PM	0.755	C
6	Anza Av & 190th St	Signalized	AM	0.836	D
			PM	0.880	D
7	Inglewood Av & 190th St	Signalized	AM	0.793	C
			PM	0.906	E
8	Hawthorne Bl & 190th St	Signalized	AM	0.865	D
			PM	0.860	D
9	Prospect Av & Beryl St	Signalized	AM	0.832	D
			PM	0.714	C
10	Harkness Ln/Parking Lot & Beryl St	AWSC	AM	132.9	F
			PM	67.7	F
11	Flagler Ln & Beryl St	AWSC	AM	92.7	F
			PM	50.7	F
12	Prospect Av & North BCHD Driveway	TWSC	AM	14.6	B
			PM	12.6	B
13	Prospect Av & Middle BCHD Driveway	Signalized	AM	0.800	C
			PM	0.499	A
14	Prospect Av & South BCHD Driveway	TWSC	AM	15.8	C
			PM	11.9	B
15	Prospect Av & Diamond St	Signalized	AM	0.534	A
			PM	0.492	A
16	Anza Av & Hallison St	Signalized	AM	0.607	B
			PM	0.598	A
17	Prospect Av & Del Amo Bl	Signalized	AM	0.846	D
			PM	0.805	D
18	Redbeam Av & Del Amo Bl	TWSC	AM	97.7	F
			PM	43.4	E
19	Wayne Av & Del Amo Bl	Signalized	AM	0.469	A
			PM	0.411	A
20	Henrietta St & Del Amo Bl	Signalized	AM	0.535	A
			PM	0.492	A
21	Entradero Av & Del Amo Bl	Signalized	AM	0.724	C
			PM	0.555	A
22	Victor St & Del Amo Bl	Signalized	AM	0.571	A
			PM	0.455	A
23	Anza Av & Del Amo Bl	Signalized	AM	0.807	D
			PM	0.973	E
24	Hawthorne Bl & Del Amo Bl	Signalized	AM	0.933	E
			PM	0.969	E
25	Prospect Av & Torrance Bl	Signalized	AM	0.745	C
			PM	0.757	C

Notes: [a] TWSC = Two-Way Stop Controlled, AWSC = All-Way Stop Controlled

[b] Signalized intersections were analyzed using ICU methodology.

[c] Unsignalized intersections were analyzed using HCM methodology. The worst performing

All other intersections are estimated to operate at LOS D or better during both peak hours. Detailed LOS worksheets are provided in **Appendix F**.

### **3.1.5 Cumulative without Project Pedestrian and Bicycle Conditions**

BCHD is, separately from this Project, pursuing grant funding to develop a Bike Path Project on the east side of the campus. The Bike Path Project would close a network gap between existing Class II facilities on Diamond Street and Beryl Street. The bicycle corridor would utilize an existing pedestrian access path between the terminus of Diamond Street and Flagler Lane and then continue north on Flagler Lane to terminate at the intersection with Beryl Street. The portion of the bicycle corridor that would run along the pedestrian access path is planned as a Class I bicycle path and the portion that would run along Flagler Lane is planned as a Class IV separated bikeway. On Flagler Lane, the Bike Path Project would also provide new sidewalk facilities on the west side of the street between Towers Street and Beryl Street. Additionally, as detailed above, the City of Redondo Beach is pursuing a bicycle facility on Beryl Street. No other substantial changes to the pedestrian and bicycle system are expected under Cumulative without Project conditions by 2032, although the South Bay Bicycle Master Plan indicates that additional Class I, II, and III facilities are planned in the study area, including on Prospect Avenue adjacent to the existing Project driveways.

### **3.1.6 Cumulative without Project Transit Conditions**

The SCAG Regional Transportation Plan anticipates increases in transit ridership by 2032. Additionally, The Metro Green Line Extension to Torrance is a planned regional transit project on the east side of the City of Redondo Beach, currently expected to begin operation between 2030 and 2033. Two alignments are still being considered for that project. Either alignment includes a station located within 2.5 miles or less from the Project site.



# 4. Project Conditions & Operational Effects Analysis

This chapter contains the assessment of traffic conditions following completion of the Project.

## 4.1 Project Trip Generation

As described in Chapter 1, ITE trip generation estimates for existing BCHD land use were compared against empirical vehicle and pedestrian counts collected at the campus to develop calibrated trip rates for each of the proposed Project's land uses, except for the Aquatics Center land use, for which a custom market analysis was used as the foundation for the trip generation estimate. Based on the results of the estimates, in Phase 1, the Project is expected to generate 1,365 daily trips, 73 AM peak hour trips, and 64 PM peak hour trips. After accounting for the existing trips on the roadway network generated by the Project uses that will be removed to accommodate the proposed uses, the Project is expected to result in negative trip generation during peak hours – that is, more trips are expected to be removed from the roadway network resulting from the removal of the existing uses than are expected to be added by the proposed Project. The reduction in trips expected with implementation of Phase I is estimated to be -1,920 daily trips, -235 AM peak hour trips, and -158 PM peak hour trips. After completion of Phase 2, the Project is expected to generate 3,660 daily trips, 271 AM peak hour trips, and 195 PM peak hour trips. After accounting for existing trips being removed from the roadway network, the Project is expected to generate a net of 376 new daily trips, -37 AM peak hour trips, and -28 PM peak hour trips. **Table 8** presents the Project trip generation estimates.

## 4.2 Project Trip Distribution

As described in Chapter 1, StreetLight cell phone data were used to develop a trip distribution pattern for the Project. These data were used to estimate the origin data of visitors to the campus, general areas in which visitors would be coming from. The trip distribution pattern also took into account Project driveway changes and accessibility, and the hierarchy and connectivity of streets in the study area. For example, drivers would be more likely to utilize more direct paths on major roadways with minimal turns rather than meandering through slower side-streets. The trip generation estimates were then assigned to the roadway network based on this distribution pattern. Project-Only traffic volumes reflecting this trip distribution/assignment pattern are provided in **Appendix D**, and trip distribution percentages are shown in **Figure 5**.



**Table 5 B  
Project Trip Generation**

Land Use			ITE Rates							Existing Trip Generation			Future Trip Generation								
	Phase 1	Phase 2	Daily	AM Peak Hour			PM Peak Hour			Calibration Rate			Calibrated Trip Generation			Phase 1			Phase 2		
				In	Out	Total	In	Out	Total	Daily	AM Peak Hour	PM Peak Hour	Daily	AM Peak Hour	PM Peak Hour	Daily	AM Peak Hour	PM Peak Hour	Daily	AM Peak Hour	PM Peak Hour
<b>Proposed Project</b>																					
Youth Wellness Center	9.100 ksf gfa	9.100 ksf gfa														288	24	31	288	24	31
Wellness Pavilion (Office)	0.000 ksf gfa	37.150 ksf gfa	9.74	86%	14%	1.16	16%	84%	1.15	1.147	1.151	0.714				0	0	0	415	50	31
PACE & Community Center (Office)	20.270 ksf gfa	20.270 ksf gfa	9.74	86%	14%	1.16	16%	84%	1.15	1.147	1.151	0.714				226	27	17	226	27	17
Center for Health & Fitness	0.000 ksf gfa	20.000 ksf gfa	28.82	66%	34%	1.76	47%	53%	2.31	2.251	2.909	1.500				0	0	0	1,297	102	69
Aquatics Center (includes outdoor pool deck)	0.000 ksf gfa	31.300 ksf gfa														0	0	0	583	46	31
Assisted Living / Memory Care	297 beds	297 beds	2.60	63%	37%	0.19	38%	62%	0.26	1.101	0.386	0.212				850	22	16	850	22	16
<b>Subtotal Proposed Project</b>																<b>1,365</b>	<b>73</b>	<b>64</b>	<b>3,660</b>	<b>271</b>	<b>195</b>
<b>Existing Uses To Be Removed</b>																					
Building 514 - Child Care Center [c]	-9.717 ksf gfa	-9.717 ksf gfa	47.62	53%	47%	11.00	47%	53%	11.12	0.829	0.850	0.583	384	91	63	-384	-91	-63	-384	-91	-63
Building 514 - Medical Office [c]	-42.103 ksf gfa	-42.103 ksf gfa	34.80	78%	22%	2.78	28%	72%	3.46	1.062	1.167	0.726	1,556	137	106	-1,556	-137	-106	-1,556	-137	-106
Building 514 - Center for Health & Fitness [c]	-12.294 ksf gfa	-12.294 ksf gfa	28.82	66%	34%	1.76	47%	53%	2.31	2.251	2.909	1.500	797	64	42	-798	-63	-43	-798	-63	-43
Building 514 (Other - Not isolatable)										1.101	0.386	0.212	547	17	11						
Building 514 - Memory Care	-120 beds	-120 beds	2.60	63%	37%	0.19	38%	62%	0.26	1.101	0.386	0.212	344	9	7	-344	-9	-7	-344	-9	-7
Building 514 - College [c]	-1.519 ksf gfa	-1.519 ksf gfa	20.25	77%	23%	2.07	50%	50%	1.86	1.101	0.386	0.212	34	1	1	-34	-1	-1	-34	-1	-1
Building 514 - General Office [c]	-15.810 ksf gfa	-15.810 ksf gfa	9.74	86%	14%	1.16	16%	84%	1.15	1.101	0.386	0.212	170	7	4	-170	-7	-4	-170	-7	-4
<b>Subtotal Existing to be Removed</b>													3,285	309	223	<b>(3,284)</b>	<b>(307)</b>	<b>(222)</b>	<b>(3,284)</b>	<b>(307)</b>	<b>(222)</b>
<b>NET NEW TRIP GENERATION (NEW - REMOVED)</b>																<b>-1,920</b>	<b>-235</b>	<b>-158</b>	<b>376</b>	<b>-37</b>	<b>-28</b>

Notes

[a] Bldg 510 is 51,500 SF GFA. At time of counts 4,998 SF of GLA space was vacant, which is an estimated 5,587 SF of GFA. This has been deducted from the space to reflect the occupied space at the time of the driveway counts.

[b] Bldg 520 is 47,700 SF GFA. At time of counts 815 SF of GLA space was vacant, which is an estimated 819 SF of GFA. This has been deducted from the space to reflect the occupied space at the time of the driveway counts.

[c] Bldg 514 is 157,681 SF GFA, and 132,900 SF of GLA (excluding 4,224 SF of outdoor child care area). At time of counts 13,044 SF of GLA was vacant, which is an estimated 15,476 SF of GFA. This has been deducted from the space to reflect occupied space at the time of the driveway counts. Land uses presented as GFA were estimated by applying overall bldg ratio of GFA to GLA.

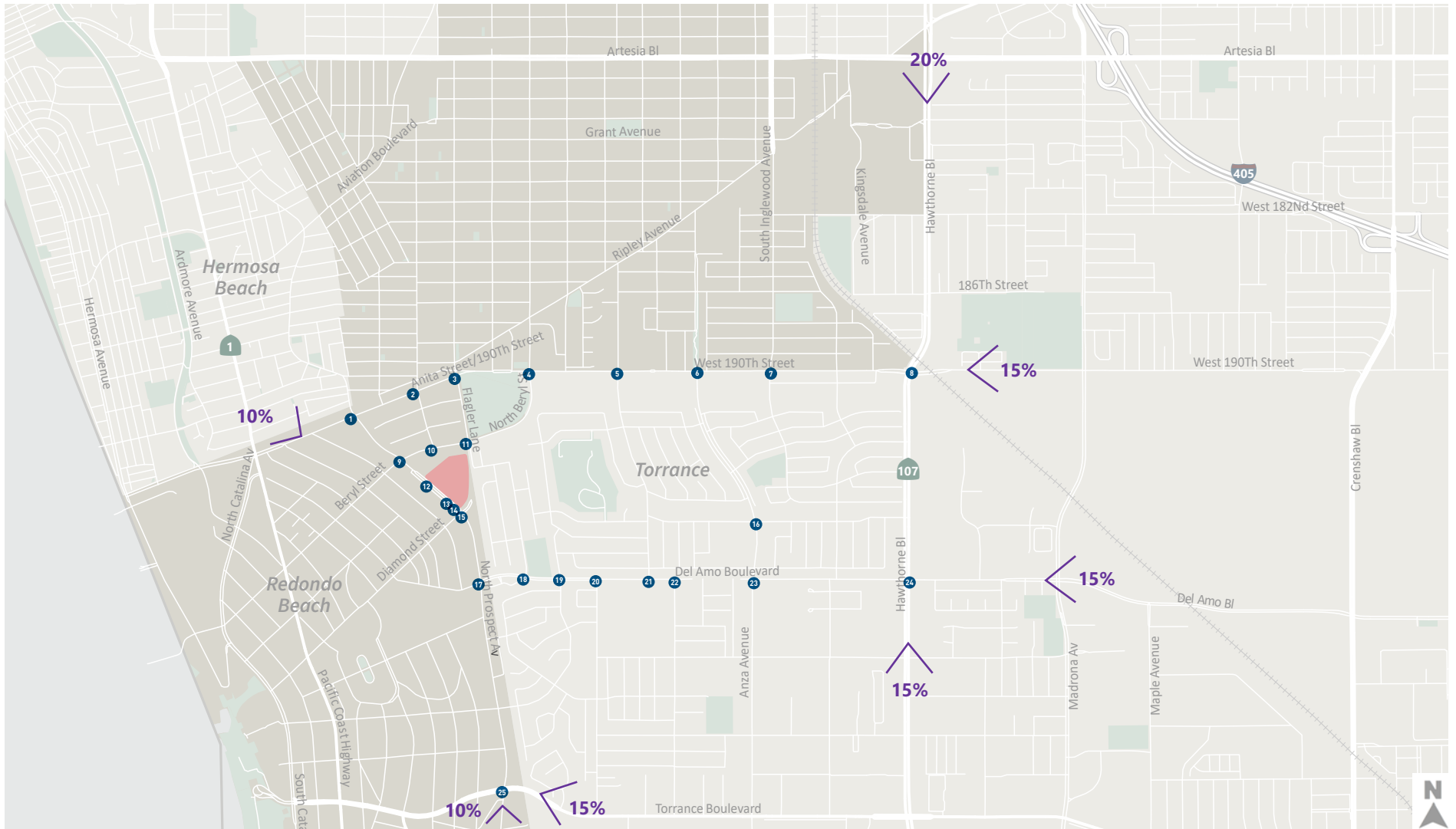

**Study Intersections**

- # Proposed Study Intersections
- Beach Cities Health District
- Ocean
- Parks



Figure 5  
Project Trip Distribution

## 4.3 Cumulative Plus Project Conditions

### 4.3.1 Intersection Traffic Volumes

The Project-only AM and PM peak hour traffic volumes described above were added to the Cumulative without Project traffic volumes to develop Cumulative plus Project traffic volumes.

### 4.3.2 Level of Service Methodology

The AM and PM peak hour Cumulative plus Project traffic volumes and intersection lane geometries were analyzed using the ICU and HCM methodologies documented above, as applicable.

### 4.3.3 Level of Service Results

**Table 9** summarizes the results of the AM and PM peak hour intersection LOS analysis for Cumulative plus Project conditions. Based on the analysis, the following seven intersections are projected to operate at LOS E or F during one or both peak hours under this scenario:

- (3) Flagler Lane & 190<sup>th</sup> Street (AM & PM peak hour)
- (7) Inglewood Avenue & 190<sup>th</sup> Street (PM peak hour)
- (10) Harkness Lane & Beryl Street (AM & PM peak hour)
- (11) Flagler Lane & Beryl Street (AM & PM peak hour)
- (18) Redbeam Avenue & Del Amo Boulevard (AM & PM peak hour)
- (23) Anza Avenue & Del Amo Boulevard (PM peak hour)
- (24) Hawthorne Boulevard & Del Amo Boulevard (AM & PM peak hour)

To determine the Project's operational effects under cumulative conditions, the analysis compared: (1) the Cumulative plus Project Conditions (2032) scenario, against (2) the Cumulative Conditions (2032) without Project scenario. As shown in **Table 9**, the Project is expected to result in modest improvements in the V/C ratio or reduction in seconds of vehicle delay at most intersections in both peak periods, due to the reduction in net new peak hour trips. A few intersections would have modest increases in the V/C ratio or seconds of vehicle delay associated with the additional driveway entrance. After applying the applicable operational effect criteria detailed in Chapter 1, the Project is not expected to have any substantive operational effects.



**Table 9 - Cumulative plus Project Year (2032) Intersection Levels of Service**

No.	Intersection	Peak Hour	Cumulative (2032) Baseline		Cumulative (2032) + Project		V/C or Delay Change?	Operational Effect?
			V/C or Delay	LOS	V/C or Delay	LOS		
1	Prospect Av & Anita St	AM	0.677	B	0.677	B	0.000	No
		PM	0.671	B	0.666	B	-0.005	No
2	Harkness Ln & Anita St	AM	0.661	B	0.659	B	-0.002	No
		PM	0.508	A	0.507	A	-0.001	No
3	Flagler Ln & 190th St	AM	143.0	F	142.8	F	-0.2	No
		PM	82.0	F	80.9	F	-1.1	No
4	Beryl St/Blossom Ln & 190th St	AM	0.760	C	0.757	C	-0.003	No
		PM	0.818	D	0.815	D	-0.003	No
5	Entradero Av/Meyer Ln & 190th St	AM	0.814	D	0.816	D	0.002	No
		PM	0.755	C	0.756	C	0.001	No
6	Anza Av & 190th St	AM	0.836	D	0.839	D	0.003	No
		PM	0.880	D	0.881	D	0.001	No
7	Inglewood Av & 190th St	AM	0.793	C	0.788	C	-0.005	No
		PM	0.906	E	0.904	E	-0.002	No
8	Hawthorne Bl & 190th St	AM	0.865	D	0.866	D	0.001	No
		PM	0.860	D	0.860	D	0.000	No
9	Prospect Av & Beryl St	AM	0.832	D	0.823	D	-0.009	No
		PM	0.714	C	0.706	C	-0.008	No
10	Harkness Ln/Parking Lot & Beryl St	AM	132.9	F	134.9	F	2.0	No
		PM	67.7	F	68.1	F	0.4	No
11	Flagler Ln & Beryl St	AM	92.7	F	95.2	F	2.5	No
		PM	50.7	F	50.9	E	0.2	No
12	Prospect Av & North BCHD Driveway	AM	14.6	B	14.8	B	0.2	No
		PM	12.6	B	12.6	B	0.0	No
13	Prospect Av & Middle BCHD Driveway	AM	0.800	C	0.808	D	0.008	No
		PM	0.499	A	0.501	A	0.002	No
14	Prospect Av & South BCHD Driveway	AM	15.8	C	15.6	C	-0.2	No
		PM	11.9	B	11.8	B	-0.1	No
15	Prospect Av & Diamond St	AM	0.534	A	0.526	A	-0.008	No
		PM	0.492	A	0.493	A	0.001	No
16	Anza Av & Hallison St	AM	0.607	B	0.607	B	0.000	No
		PM	0.598	A	0.598	A	0.000	No
17	Prospect Av & Del Amo Bl	AM	0.846	D	0.847	D	0.001	No
		PM	0.805	D	0.805	D	0.000	No
18	Redbeam Av & Del Amo Bl	AM	97.7	F	93.3	E	-4.4	No
		PM	43.4	E	42.6	E	-0.8	No
19	Wayne Av & Del Amo Bl	AM	0.469	A	0.464	A	-0.005	No
		PM	0.411	A	0.408	A	-0.003	No
20	Henrietta St & Del Amo Bl	AM	0.535	A	0.536	A	0.001	No
		PM	0.492	A	0.493	A	0.001	No
21	Entradero Av & Del Amo Bl	AM	0.724	C	0.720	C	-0.004	No
		PM	0.555	A	0.553	A	-0.002	No
22	Victor St & Del Amo Bl	AM	0.571	A	0.573	A	0.002	No
		PM	0.455	A	0.456	A	0.001	No
23	Anza Av & Del Amo Bl	AM	0.807	D	0.803	D	-0.004	No
		PM	0.973	E	0.971	E	-0.002	No
24	Hawthorne Bl & Del Amo Bl	AM	0.933	E	0.931	E	-0.002	No
		PM	0.969	E	0.966	E	-0.003	No
25	Prospect Av & Torrance Bl	AM	0.745	C	0.744	C	-0.001	No
		PM	0.757	C	0.755	C	-0.002	No

Notes: [a] TWSC = Two-Way Stop Controlled, AWSC = All-Way Stop Controlled

[b] Signalized intersections were analyzed using ICU methodology.

[c] Unsignalized intersections were analyzed using HCM methodology. The worst performing approach was reported for TWSC

#### **4.3.4 Cumulative plus Project Pedestrian and Bicycle Conditions**

Development of the proposed Project would not result in any changes to the pedestrian and bicycle system under Cumulative plus Project conditions. Due to the proposed pedestrian entrance to the campus at the intersection of Beryl Street and Flagler Lane, it is expected that pedestrian activity would increase at this location.

#### **4.3.5 Cumulative plus Project Transit Conditions**

Development of the proposed Project would not result in any changes to transit routes within the study area compared to Cumulative without Project conditions. However, due to the proposed inbound Project driveway on Beryl Street, the existing Beach Cities Transit bus stop on eastbound Beryl Street would need to be relocated approximately 150 feet east to the southwest corner of Beryl Street and Flagler Lane.



# 5. Summary

This study was prepared to analyze the potential transportation effects and operational effects associated with the BCHD Healthy Living Campus Master Plan Project. The following summarizes the results of the study:

- The proposed Project involves the demolition of existing structures on the BCHD campus and the long-term redevelopment in two phases of the campus and the adjacent vacant lot with new public health care facilities that would expand public health care and related offerings, as well as address deteriorating buildings in need of extensive maintenance. New construction in Phase 1 would include an RCFE structure providing 60 replacement memory care units and 157 new assisted living units, offices for BCHD staff, 14,000 sf of space for PACE, and 6,270 sf of Community Services space. Phase 2 of the Project would include a Community Health and Wellness Center with 31,300 sf of Aquatics Center, 20,000 sf Center for Health and Fitness, a 37,150 sf Wellness Pavilion, and a 7,100 sf Youth Wellness Center. A new subterranean parking garage and surface parking lot would accommodate up to 739 vehicles. Site access would continue to be provided by the three existing driveways on Prospect Avenue, as well as via two new driveways directly into the planned subterranean parking facility at the northeast corner of the campus. The proposed Project is expected to be completed by 2032.
- The proposed Project is expected to generate fewer vehicle trips compared to those already traveling to the existing BCHD campus.
- In consultation with City of Redondo Beach and City of Torrance staff, the study area was selected to include the intersections most likely to be affected by traffic generated by the Project. A total of 25 intersections were identified for analysis, 19 of which operate under signal control, and six of which are stop-controlled. All signalized intersections were analyzed using the ICU methodology per each City's requirements. Unsignalized intersections were analyzed using the HCM methodology.
- The Project's potential for substantial traffic operational effects was assessed against a Cumulative Baseline (2032).
- The Project is not expected to have any substantive operational effects compared to both the Cumulative baseline. Under Cumulative baseline and plus Project conditions, five intersections operate at LOS E or worse during one or more peak period. At all intersections in both peak periods, implementation of the proposed Project results in an improvement to V/C or reduction in seconds of delay.

- The Project is not expected to significantly degrade transit operations and facilities or pedestrian and bicycle modes. The Project would relocate a Beach Cities Transit bus stop on the south side of Beryl Street to the southwest corner of Beryl Street and Flagler Lane.



# Appendix A – Trip Generation Methodology



## **TRIP GENERATION CALIBRATION APPROACH**

*Trip Generation, 10<sup>th</sup> Edition* (Institute of Transportation Engineers [ITE], 2017) represents the industry standard for estimating trip generation and is based on a compilation of empirical trip generation surveys at locations throughout the country. Using ITE is generally a defensible approach. However, ITE always recommends utilizing local data where it is available, and based on feedback from the Cities of Redondo Beach and Torrance, Fehr & Peers conducted an empirical trip generation study to validate, and if necessary calibrate ITE trip generation rates to reflect site conditions on the BCHD Campus.

A full day (24-hour) of driveway counts were collected at the Project site on Tuesday October 22, 2019. While driveway counts can be used for validating overall campus trip generation, they do not allow for the analysis of how trip generation rates for a particular land use at the BCHD campus varies from ITE rates. Providing more detailed trip rate validation further enhances the accuracy and defensibility of the trip rates used in the EIR, as well as allows for the use of locally accurate trip rates by land use, so that the Project trip generation estimates accurately account for the expected trip generation with the change in mix of land uses in the Project.

In order to assess the difference by land use type, 24-hour pedestrian counts were conducted at the entrances to each building on campus on the same day. Buildings 510 and 520 both contain exclusively Medical Office functions, so pedestrian counts at those buildings were used to develop a BCHD Medical Office trip rate to compare with ITE. Building 514, because it is mixed use, cannot be fully isolated by land use. However, because the Childcare Center has a dedicated entrance to the building, that use could be isolated and compared with ITE. The Medical Office contained within Building 514 was assumed to have the same patterns as buildings 510 and 520, so those calibration rates were applied.

The remaining Building 514 uses (Assisted Living, Education, General Office), cannot be individually compared with the ITE rate, but could be compared collectively.

Counts of members in the CHF were provided for 2019 for the Center for Health and Fitness (CHF). These data were used to estimate existing trips associated with the CHF for the purposes of validation since the CHF could not be isolated. Weekday member counts were averaged across weekdays and by hour. In order to estimate vehicle trips, the average visit length was assumed to be 90 minutes. Conversion from counted persons to vehicle trips was made by applying the overall average vehicle occupancy of 1.37 for the campus which was calculated by comparing the total pedestrian counts for the building doorways with the vehicle counts of the campus driveways. The CHF is primarily class/program focused and caters to older clientele who are more likely to travel to activities with a companion. CHF estimated existing trips are included in a table in this appendix.

The overall trip rate calibration is included in a table in the body of this report.

### **TRIP GENERATION METHODOLOGY – AQUATICS & YOUTH WELLNESS CENTERS**

The body of this report details the phased trip generation estimates. Appendix C includes the memorandum prepared by the Aquatics Consultant that was used to develop aquatics center trip generation estimates from the market evaluation. The following table in this appendix details the trip generation derived from the market estimates for the Aquatics Center.

Due to the COVID-19 pandemic, and closure of many recreation and aquatics centers in the area, vehicle counts were unable to be collected. The City of Redondo Beach has location of the South Bay Aquatics Center located on Artesia Boulevard. This facility has not been operating with regular class schedules, so would not result in reliable data for validating the trip generation estimates. StreetLight data was reviewed for 2019 for the South Bay Aquatics center as an alternative source for trip generation data. However, it did not have a sufficient sample size to be used as reliable counts.

The Youth Wellness Center program assumptions prepared by the expected operator were used to estimate the overall number of employees and participating students. The assumptions for mode split were made based on reasonable estimates given that the program will primarily be serving students in the immediate area. A table detailing these assumptions are included in this appendix.

**Center for Health & Fitness Existing Trip Generation**

Time of Count	M-F Average Count Members in Gym	Person Trips			Vehicle Trips		
		Arrival	Departure	Total	In	Out	Total
5:30:00 AM	6	6	0	6	4	0	4
6:00:00 AM	20	14	0	14	10	0	10
6:30:00 AM	35	15	0	15	11	0	11
7:00:00 AM	47	18	6	24	14	4	18
7:30:00 AM	51	18	14	32	13	10	23
8:00:00 AM	65	29	15	44	21	11	32
8:30:00 AM	73	26	18	44	19	13	32
9:00:00 AM	95	40	18	58	29	13	42
9:30:00 AM	98	32	29	61	24	21	45
10:00:00 AM	106	34	26	60	25	19	44
10:30:00 AM	92	26	40	66	19	29	48
11:00:00 AM	94	34	32	66	25	23	48
11:30:00 AM	85	25	34	59	18	25	43
12:00:00 PM	80	21	26	47	15	19	34
12:30:00 PM	66	20	34	54	14	25	39
1:00:00 PM	57	16	25	41	12	18	30
1:30:00 PM	52	16	21	37	12	15	27
2:00:00 PM	48	16	20	36	12	14	26
2:30:00 PM	48	16	16	32	12	11	23
3:00:00 PM	44	12	16	28	9	11	20
3:30:00 PM	41	13	16	29	9	12	21
4:00:00 PM	41	16	16	32	12	11	23
4:30:00 PM	43	14	12	26	10	9	19
5:00:00 PM	45	15	13	28	11	9	20
5:30:00 PM	46	17	16	33	12	12	24
6:00:00 PM	43	11	14	25	8	10	18
6:30:00 PM	38	10	15	25	7	11	18
7:00:00 PM	32	11	17	28	8	12	20
7:30:00 PM	26	5	11	16	4	8	12
8:00:00 PM	19	3	10	13	2	7	9
8:30:00 PM	11	3	11	14	2	8	10
9:00:00 PM	5	0	6	6	0	4	4
<b>Total</b>		552	547	1,099	403	394	797

**Aquatics Center Trip Generation Estimates**

	NSGA Factors	Beach Cities Population	Swimming Days / Year	Annual Swimming Days	BCHD Market Capture	BCHD Swimming Days	Weekday Swimming Days % [a]	Annual Weekday Visits	Weekend Swimming Days %	Annual Weekend Visits	Avg Weekday Visits	Avg Weekend Visits	% Internal to Site	Avg Vehicle Occupancy	Avg Weekday External Vehicle Trips	Avg Weekend External Vehicle Trips
Service Area Population that swims (7+)		86,145									251	104				
% Frequent Swimmers (112 days)	8.5%	7,322	112	820,064	3.0%	24,602	71%	17,395	29%	7,207	69	69	20%	1	110	110
% Infrequent Swimmers (67 days)	41.7%	35,922	67	2,406,774	3.0%	72,203	25%	51,051	75%	21,152	203	203	10%	2	365	365
% Occasional Swimmers (15 days)	49.8%	42,900	15	643,500	3.0%	19,305	10%	13,649	90%	5,656	54	54	0%	3	108	108
				3,870,338		116,110		82,095		34,015	326	326			583	583

**Notes**

[a] Ratio of weekday to weekend swimming days for frequent swimmers assumed to be ratio of weekday (non holiday) weekdays to weekend days. Infrequent and occasional assumed to be predominantly swimming on weekends

**Youth Wellness Center Trip Generation Estimates (based on Program Assumptions)**

	Population Size	Auto Mode Choice	Trips Per Day	Total Average Daily Trips	Program	AM Peak Hour (8-9AM)	PM Peak Hour (4-5PM)	Notes
<b>Clients</b>								
School Age (12-18)	100	25%	4	100	3PM-8PM	0	20	Auto assumed to be all drop off (4 trips instead of 2); assume 1/5 of daily trips in PH
Young Adults (18-25)	100	75%	2	150	9AM-3PM	13	0	Self Drive, assume 1/6 of arrivals in PH
<b>Staff</b>								
Full Time								
Medical	8	100%	2	16		4	4	Self Drive, assume 50% arrive & depart in PHs
Executive	3	100%	2	6		3	3	Self Drive, assume 100% arrive & depart in PHs
Part Time	8	100%	2	16		4	4	Self Drive, assume 50% arrive & depart in PHs
<b>Total</b>				<b>288</b>		<b>24</b>	<b>31</b>	

# Appendix B – Driveway & Pedestrian Counts

### IN & OUT

Prospect I Medical 510 Dwy N/O Prospect Ave

Day: Tuesday  
Date: 10/22/2019

City: Redondo Beach  
Project #: CA19\_5613\_002

DAILY TOTALS				IN	OUT					Total
				653	360					1,013
AM Period	IN	OUT		TOTAL	PM Period	IN	OUT		TOTAL	TOTAL
0:00	2	0		2	12:00	6	6		12	
0:15	0	1		1	12:15	14	6		20	
0:30	0	0		0	12:30	9	10		19	
0:45	0	2	0	1	12:45	10	39	10	32	71
1:00	0	0		0	13:00	16	5		21	
1:15	0	0		0	13:15	17	7		24	
1:30	0	0		0	13:30	7	3		10	
1:45	0	0		0	13:45	13	53	2	17	70
2:00	0	0		0	14:00	4	9		13	
2:15	0	0		0	14:15	7	8		15	
2:30	0	0		0	14:30	8	4		12	
2:45	0	0		0	14:45	8	27	6	27	54
3:00	0	0		0	15:00	11	5		16	
3:15	0	0		0	15:15	6	6		12	
3:30	0	0		0	15:30	9	7		16	
3:45	0	0		0	15:45	9	35	15	33	68
4:00	0	0		0	16:00	8	7		15	
4:15	0	0		0	16:15	11	7		18	
4:30	0	0		0	16:30	16	9		25	
4:45	0	0		0	16:45	7	42	15	38	80
5:00	1	0		1	17:00	12	12		24	
5:15	1	0		1	17:15	10	11		21	
5:30	5	2		7	17:30	11	11		22	
5:45	4	11	0	2	17:45	3	36	9	43	79
6:00	4	1		5	18:00	4	2		6	
6:15	7	0		7	18:15	3	4		7	
6:30	5	1		6	18:30	4	1		5	
6:45	1	17	0	2	18:45	3	14	1	8	22
7:00	11	0		11	19:00	1	1		2	
7:15	17	1		18	19:15	1	0		1	
7:30	18	6		24	19:30	1	0		1	
7:45	29	75	0	7	19:45	2	5	0	1	6
8:00	25	5		30	20:00	1	3		4	
8:15	24	6		30	20:15	1	4		5	
8:30	27	7		34	20:30	0	3		3	
8:45	34	110	0	28	20:45	0	2	0	10	12
9:00	33	14		47	21:00	0	0		0	
9:15	20	9		29	21:15	0	0		0	
9:30	16	4		20	21:30	1	1		2	
9:45	23	92	7	34	21:45	0	1	0	1	2
10:00	17	10		27	22:00	0	2		2	
10:15	12	8		20	22:15	0	1		1	
10:30	11	8		19	22:30	0	0		0	
10:45	19	59	11	37	22:45	0	0		3	3
11:00	11	10		21	23:00	0	0		0	
11:15	10	9		19	23:15	0	0		0	
11:30	5	9		14	23:30	0	0		0	
11:45	7	33	8	36	23:45	0	0		0	
<b>TOTALS</b>	<b>399</b>	<b>147</b>		<b>546</b>	<b>TOTALS</b>	<b>254</b>	<b>213</b>			<b>467</b>
<b>SPLIT %</b>	<b>73.1%</b>	<b>26.9%</b>		<b>53.9%</b>	<b>SPLIT %</b>	<b>54.4%</b>	<b>45.6%</b>			<b>46.1%</b>

DAILY TOTALS				IN	OUT					Total	
				653	360					1,013	
AM Peak Hour	8:15	8:30		8:15	PM Peak Hour	13:00	16:45		16:30		
AM Pk Volume	118	40		155	PM Pk Volume	53	49		92		
Pk Hr Factor	0.868	0.714		0.824	Pk Hr Factor	0.779	0.817		0.920		
7 - 9 Volume	185	35	0	0	220	4 - 6 Volume	78	81	0	0	159
7 - 9 Peak Hour	8:00	8:00		8:00	4 - 6 Peak Hour	16:15	16:45		16:30		
7 - 9 Pk Volume	110	28		138	4 - 6 Pk Volume	46	49		0	0	92
Pk Hr Factor	0.809	0.700	0.000	0.000	0.784	Pk Hr Factor	0.719	0.817	0.000	0.000	0.920

### VOLUME

Silverado Beach Cities Memory Care Community Dwy N/O N Prospect Ave

Day: Tuesday  
Date: 10/22/2019

City: Redondo Beach  
Project #: CA19\_5612\_001

DAILY TOTALS					IN	OUT						Total		
					129	583	0	0						712
AM Period	IN	OUT	EB	WB	TOTAL	PM Period	IN	OUT	EB	WB	TOTAL			
00:00	0	1			1	12:00	3	20			23			
00:15	0	1			1	12:15	1	17			18			
00:30	1	0			1	12:30	6	11			17			
00:45	0	1	0	2	0	12:45	6	16	8	56	14			
01:00	0	0			0	13:00	1	10			11			
01:15	0	0			0	13:15	1	10			11			
01:30	0	0			0	13:30	2	15			17			
01:45	0	0			0	13:45	3	7	11	46	14			
02:00	0	0			0	14:00	3	17			20			
02:15	0	0			0	14:15	1	10			11			
02:30	0	0			0	14:30	4	13			17			
02:45	0	0			0	14:45	3	11	10	50	13			
03:00	0	0			0	15:00	4	13			17			
03:15	0	0			0	15:15	1	10			11			
03:30	0	0			0	15:30	1	13			14			
03:45	1	1	0		1	15:45	6	12	12	48	18			
04:00	0	0			0	16:00	1	10			11			
04:15	0	0			0	16:15	4	11			15			
04:30	0	0			0	16:30	3	7			10			
04:45	1	1	0		1	16:45	1	9	16	44	17			
05:00	0	0			0	17:00	5	25			30			
05:15	1	1			2	17:15	3	9			12			
05:30	1	1			2	17:30	1	9			10			
05:45	0	2	0	2	0	17:45	1	10	6	49	7			
06:00	0	1			1	18:00	4	14			18			
06:15	0	2			2	18:15	2	3			5			
06:30	0	2			2	18:30	1	8			9			
06:45	0	3	8		3	18:45	1	8	5	30	6			
07:00	0	2			2	19:00	0	2			2			
07:15	1	1			2	19:15	1	3			4			
07:30	1	2			3	19:30	1	7			8			
07:45	1	3	3	8	4	19:45	0	2	1	13	1			
08:00	2	4			6	20:00	0	3			3			
08:15	1	5			6	20:15	0	1			1			
08:30	2	5			7	20:30	3	4			7			
08:45	3	8	20	34	23	20:45	1	4	2	10	3			
09:00	2	13			15	21:00	5	11			16			
09:15	1	8			9	21:15	1	1			2			
09:30	4	9			13	21:30	0	0			0			
09:45	1	8	18	48	19	21:45	1	7	2	14	3			
10:00	0	22			22	22:00	0	0			0			
10:15	2	17			19	22:15	0	0			0			
10:30	5	16			21	22:30	0	0			0			
10:45	3	10	10	65	13	22:45	0	0			0			
11:00	3	12			15	23:00	0	0			0			
11:15	0	12			12	23:15	0	0			0			
11:30	2	18			20	23:30	0	1			1			
11:45	3	8	12	54	15	23:45	1	1	1	2	2			
<b>TOTALS</b>	<b>42</b>	<b>221</b>			<b>263</b>	<b>TOTALS</b>	<b>87</b>	<b>362</b>			<b>449</b>			
<b>SPLIT %</b>	<b>16.0%</b>	<b>84.0%</b>			<b>36.9%</b>	<b>SPLIT %</b>	<b>19.4%</b>	<b>80.6%</b>			<b>63.1%</b>			

DAILY TOTALS					IN	OUT	EB	WB	Total
					129	583	0	0	712

AM Peak Hour	10:15	09:45		09:45	PM Peak Hour	12:00	16:15		12:00		
AM Pk Volume	13	73		81	PM Pk Volume	16	59		72		
Pk Hr Factor	0.650	0.830		0.920	Pk Hr Factor	0.667	0.590		0.783		
7 - 9 Volume	11	42	0	0	53	4 - 6 Volume	19	93	0	0	112
7 - 9 Peak Hour	08:00	08:00		08:00	4 - 6 Peak Hour	16:15	16:15				16:15
7 - 9 Pk Volume	8	34	0	0	42	4 - 6 Pk Volume	13	59	0	0	72
Pk Hr Factor	0.667	0.425	0.000	0.000	0.457	Pk Hr Factor	0.650	0.590	0.000	0.000	0.600



### IN & OUT

Beach Cities Health District Dwy N/O Prospect Ave

Day: Tuesday  
Date: 10/22/2019

City: Redondo Beach  
Project #: CA19\_5613\_001

DAILY TOTALS				IN	OUT					Total
				2,603	2,385					4,988
AM Period	IN	OUT	TOTAL	PM Period	IN	OUT	TOTAL			
0:00	0	0	0	12:00	36	61	97			
0:15	0	0	0	12:15	42	64	106			
0:30	0	0	0	12:30	41	62	103			
0:45	0	1	1	12:45	66	185	237	116	422	
1:00	1	2	3	13:00	60	40	100			
1:15	0	0	0	13:15	63	27	90			
1:30	1	0	1	13:30	55	47	102			
1:45	0	2	2	13:45	62	240	302	103	395	
2:00	1	0	1	14:00	54	54	108			
2:15	1	0	1	14:15	71	47	118			
2:30	2	1	3	14:30	43	56	99			
2:45	2	6	8	14:45	40	208	248	84	409	
3:00	1	1	2	15:00	50	50	100			
3:15	1	1	2	15:15	39	40	79			
3:30	0	0	0	15:30	37	57	94			
3:45	0	2	2	15:45	32	158	190	101	374	
4:00	1	1	2	16:00	32	45	77			
4:15	0	0	0	16:15	47	58	105			
4:30	1	1	2	16:30	29	57	86			
4:45	4	6	10	16:45	21	129	150	70	338	
5:00	4	0	4	17:00	23	81	104			
5:15	9	1	10	17:15	24	55	79			
5:30	6	0	6	17:30	13	39	52			
5:45	13	32	45	17:45	14	74	88	48	283	
6:00	12	4	16	18:00	9	44	53			
6:15	13	3	16	18:15	50	50	100			
6:30	28	5	33	18:30	21	28	49			
6:45	35	88	123	18:45	15	95	110	26	228	
7:00	32	8	40	19:00	12	8	20			
7:15	37	8	45	19:15	24	15	39			
7:30	46	10	56	19:30	9	12	21			
7:45	92	207	299	19:45	22	67	89	33	113	
8:00	80	24	104	20:00	14	66	80			
8:15	74	26	100	20:15	3	12	15			
8:30	80	27	107	20:30	1	7	8			
8:45	95	329	424	20:45	2	20	22	10	113	
9:00	75	42	117	21:00	1	15	16			
9:15	61	50	111	21:15	2	3	5			
9:30	68	37	105	21:30	6	1	7			
9:45	71	275	346	21:45	9	18	27	11	39	
10:00	69	69	138	22:00	3	1	4			
10:15	57	47	104	22:15	1	2	3			
10:30	66	54	120	22:30	2	14	16			
10:45	66	258	324	22:45	0	6	6	1	24	
11:00	50	68	118	23:00	0	3	3			
11:15	72	64	136	23:15	0	1	1			
11:30	36	81	117	23:30	0	1	1			
11:45	40	198	238	23:45	0	2	2	7		
<b>TOTALS</b>	<b>1403</b>	<b>840</b>	<b>2243</b>	<b>TOTALS</b>	<b>1200</b>	<b>1545</b>	<b>2745</b>			
<b>SPLIT %</b>	<b>62.6%</b>	<b>37.4%</b>	<b>45.0%</b>	<b>SPLIT %</b>	<b>43.7%</b>	<b>56.3%</b>	<b>55.0%</b>			

DAILY TOTALS				IN	OUT					Total
				2,603	2,385					4,988

AM Peak Hour	8:00	11:00	10:30	PM Peak Hour	12:45	16:15	13:30			
AM Pk Volume	329	272	489	PM Pk Volume	244	245	431			
Pk Hr Factor	0.866	0.840	0.899	Pk Hr Factor	0.924	0.756	0.913			
7 - 9 Volume	536	149	685	4 - 6 Volume	203	418	621			
7 - 9 Peak Hour	8:00	8:00	8:00	4 - 6 Peak Hour	16:00	16:15	16:15			
7 - 9 Pk Volume	329	108	437	4 - 6 Pk Volume	129	245	365			
Pk Hr Factor	0.866	0.871	0.867	Pk Hr Factor	0.686	0.756	0.869			

### Pedestrian Study

Location: Facing 520 Building Side Entrance(Key Card Only) N/O N Prospect Ave  
 City: Redondo Beach  
 Date: 10/22/2019  
 Day: Tuesday

TIME	Peds				TOTAL
	Individual Peds		Groups		
	In	Out	In	Out	
12:00 AM	0	0	0	0	0
12:15 AM	0	0	0	0	0
12:30 AM	0	0	0	0	0
12:45 AM	0	0	0	0	0
1:00 AM	0	0	0	0	0
1:15 AM	0	0	0	0	0
1:30 AM	0	0	0	0	0
1:45 AM	0	0	0	0	0
2:00 AM	0	0	0	0	0
2:15 AM	0	0	0	0	0
2:30 AM	0	0	0	0	0
2:45 AM	0	0	0	0	0
3:00 AM	0	0	0	0	0
3:15 AM	0	0	0	0	0
3:30 AM	0	0	0	0	0
3:45 AM	0	0	0	0	0
4:00 AM	0	0	0	0	0
4:15 AM	0	0	0	0	0
4:30 AM	0	0	0	0	0
4:45 AM	0	0	0	0	0
5:00 AM	0	0	0	0	0
5:15 AM	0	0	0	0	0
5:30 AM	0	0	0	0	0
5:45 AM	0	0	0	0	0
6:00 AM	0	0	0	0	0
6:15 AM	0	0	0	0	0
6:30 AM	0	0	0	0	0
6:45 AM	0	0	0	0	0
7:00 AM	0	0	0	0	0
7:15 AM	0	0	0	0	0
7:30 AM	0	0	0	0	0
7:45 AM	0	0	0	0	0
8:00 AM	0	0	0	0	0
8:15 AM	1	0	0	0	1
8:30 AM	0	1	0	0	1
8:45 AM	0	0	0	0	0
9:00 AM	0	0	0	0	0
9:15 AM	0	0	0	0	0
9:30 AM	0	0	0	0	0
9:45 AM	0	0	0	0	0
10:00 PM	0	0	0	0	0
10:15 PM	0	0	0	0	0
10:30 PM	0	0	0	0	0
10:45 PM	0	0	0	0	0
11:00 PM	0	0	0	0	0
11:15 PM	0	0	0	0	0
11:30 PM	0	0	0	0	0
11:45 PM	0	1	0	0	1
12:00 AM	1	0	0	0	1
12:15 AM	0	0	0	0	0
12:30 AM	0	1	0	0	1
12:45 AM	0	0	0	0	0
1:00 AM	0	0	0	0	0
1:15 AM	0	0	0	0	0
1:30 AM	1	1	0	0	2
1:45 AM	0	0	0	0	0
2:00 PM	0	0	0	0	0
2:15 PM	0	0	0	0	0
2:30 PM	0	0	0	0	0
2:45 PM	0	0	0	0	0
3:00 PM	0	0	0	0	0
3:15 PM	0	0	0	0	0
3:30 PM	0	0	0	0	0
3:45 PM	0	0	0	0	0
4:00 PM	0	0	0	0	0
4:15 PM	0	0	0	0	0
4:30 PM	0	1	0	0	1
4:45 PM	0	0	0	0	0
5:00 PM	0	0	0	0	0
5:15 PM	0	0	0	0	0
5:30 PM	0	0	0	0	0
5:45 PM	0	0	0	0	0
6:00 PM	0	1	0	0	1
6:15 PM	0	0	0	0	0
6:30 PM	0	0	0	0	0
6:45 PM	0	0	0	0	0
7:00 PM	0	0	0	0	0
7:15 PM	0	0	0	0	0
7:30 PM	0	0	0	0	0
7:45 PM	0	0	0	0	0
8:00 PM	0	0	0	0	0
8:15 PM	0	0	0	0	0
8:30 PM	0	0	0	0	0
8:45 PM	0	0	0	0	0
9:00 PM	0	0	0	0	0
9:15 PM	0	0	0	0	0
9:30 PM	0	0	0	0	0
9:45 PM	0	0	0	0	0
10:00 PM	0	0	0	0	0
10:15 PM	0	0	0	0	0
10:30 PM	0	0	0	0	0
10:45 PM	0	0	0	0	0
11:00 PM	0	0	0	0	0
11:15 PM	0	0	0	0	0
11:30 PM	0	0	0	0	0
11:45 PM	0	0	0	0	0
<b>Grand Totals</b>	<b>3</b>	<b>6</b>	<b>0</b>	<b>0</b>	<b>9</b>

## Pedestrian Study

Location: 520 Side Entrance Main Entrance N/O N Prospect Ave

City: Redondo Beach

Date: 10/22/2019

Day: Tuesday

TIME	Peds				TOTAL
	Individual Peds		Groups		
	In	Out	In	Out	
12:00 AM	0	0	0	0	0
12:15 AM	0	0	0	0	0
12:30 AM	0	0	0	0	0
12:45 AM	0	0	0	0	0
1:00 AM	0	0	0	0	0
1:15 AM	0	0	0	0	0
1:30 AM	0	0	0	0	0
1:45 AM	0	0	0	0	0
2:00 AM	0	0	0	0	0
2:15 AM	0	0	0	0	0
2:30 AM	0	0	0	0	0
2:45 AM	0	0	0	0	0
3:00 AM	0	0	0	0	0
3:15 AM	0	1	0	0	1
3:30 AM	0	0	0	0	0
3:45 AM	0	0	0	0	0
4:00 AM	0	0	0	0	0
4:15 AM	0	0	0	0	0
4:30 AM	0	0	0	0	0
4:45 AM	0	0	0	0	0
5:00 AM	0	0	0	0	0
5:15 AM	0	0	0	0	0
5:30 AM	0	0	0	0	0
5:45 AM	0	0	0	0	0
6:00 AM	0	0	0	0	0
6:15 AM	0	0	0	0	0
6:30 AM	1	0	0	0	1
6:45 AM	4	0	1	0	5
7:00 AM	7	1	1	0	9
7:15 AM	7	2	0	0	9
7:30 AM	15	2	1	0	18
7:45 AM	12	3	1	1	17
8:00 AM	18	2	2	0	22
8:15 AM	12	14	0	1	27
8:30 AM	21	11	1	0	33
8:45 AM	14	17	1	2	34
9:00 AM	26	22	3	1	52
9:15 AM	24	25	3	1	53
9:30 AM	20	24	2	2	48
9:45 AM	32	24	0	2	58
10:00 PM	21	24	2	3	50
10:15 PM	21	21	6	2	50
10:30 PM	26	23	4	5	58
10:45 PM	23	24	4	2	53
11:00 PM	31	32	3	5	71
11:15 PM	27	20	3	2	52
11:30 PM	21	28	1	4	54
11:45 PM	18	20	2	4	44
12:00 AM	15	25	3	4	47
12:15 AM	14	20	2	1	37
12:30 AM	19	28	1	4	52
12:45 AM	23	19	2	1	45
1:00 AM	21	15	3	1	40
1:15 AM	29	10	4	1	44
1:30 AM	21	16	1	1	39
1:45 AM	26	22	2	2	52
2:00 PM	32	25	3	2	62
2:15 PM	18	27	2	3	50
2:30 PM	24	20	0	1	45
2:45 PM	11	21	0	2	34
3:00 PM	26	14	4	2	46
3:15 PM	28	19	4	4	55
3:30 PM	22	25	3	3	53
3:45 PM	22	26	1	6	55
4:00 PM	18	20	3	1	42
4:15 PM	17	17	1	1	36
4:30 PM	10	28	0	2	40
4:45 PM	8	15	0	2	25
5:00 PM	9	20	0	2	31
5:15 PM	6	17	0	1	24
5:30 PM	5	9	0	2	16
5:45 PM	5	7	0	1	13
6:00 PM	1	7	0	2	10
6:15 PM	1	1	0	0	2
6:30 PM	0	3	0	0	3
6:45 PM	0	0	0	0	0
7:00 PM	0	2	0	0	2
7:15 PM	0	0	0	0	0
7:30 PM	0	0	0	0	0
7:45 PM	3	6	0	1	10
8:00 PM	0	0	0	0	0
8:15 PM	0	0	0	0	0
8:30 PM	1	1	0	0	2
8:45 PM	1	1	0	0	2
9:00 PM	0	0	0	0	0
9:15 PM	2	2	0	0	4
9:30 PM	0	0	0	0	0
9:45 PM	0	0	0	0	0
10:00 PM	0	0	0	0	0
10:15 PM	0	0	0	0	0
10:30 PM	0	0	0	0	0
10:45 PM	0	0	0	0	0
11:00 PM	0	0	0	0	0
11:15 PM	0	0	0	0	0
11:30 PM	0	0	0	0	0
11:45 PM	0	0	0	0	0
<b>Grand Totals</b>	<b>839</b>	<b>828</b>	<b>80</b>	<b>90</b>	<b>1837</b>

### Pedestrian Study

Location: 520 Building Elevator Parking Garage Entrance Underground/N/O N Prospect Ave

City: Redondo Beach

Date: 10/22/2019

Day: Tuesday

TIME	Peds				TOTAL	INS	OUTS
	Individual Peds		Groups				
	In	Out	In	Out			
12:00 AM	0	0	0	0	0	0	0
12:15 AM	0	0	0	0	0		
12:30 AM	0	0	0	0	0		
12:45 AM	0	0	0	0	0		
1:00 AM	0	0	0	0	0	0	0
1:15 AM	0	0	0	0	0		
1:30 AM	0	0	0	0	0		
1:45 AM	0	0	0	0	0		
2:00 AM	0	0	0	0	0	0	0
2:15 AM	0	0	0	0	0		
2:30 AM	0	0	0	0	0		
2:45 AM	0	0	0	0	0		
3:00 AM	0	0	0	0	0	0	0
3:15 AM	0	0	0	0	0		
3:30 AM	0	0	0	0	0		
3:45 AM	0	0	0	0	0		
4:00 AM	0	0	0	0	0	0	0
4:15 AM	0	0	0	0	0		
4:30 AM	0	0	0	0	0		
4:45 AM	0	0	0	0	0		
5:00 AM	0	0	0	0	0	0	0
5:15 AM	0	0	0	0	0		
5:30 AM	0	0	0	0	0		
5:45 AM	0	0	0	0	0		
6:00 AM	0	0	0	0	0	1	0
6:15 AM	0	0	0	0	0		
6:30 AM	1	0	0	0	1		
6:45 AM	0	0	0	0	0		
7:00 AM	4	0	0	0	4	14	0
7:15 AM	1	0	0	0	1		
7:30 AM	5	0	0	0	5		
7:45 AM	4	0	0	0	4		
8:00 AM	12	0	2	0	14	33	4
8:15 AM	4	0	0	0	4		
8:30 AM	10	4	1	0	15		
8:45 AM	7	0	0	0	7		
9:00 AM	3	4	0	1	8	15	11
9:15 AM	7	2	0	0	9		
9:30 AM	1	2	0	0	3		
9:45 AM	4	3	1	1	9		
10:00 PM	5	7	0	1	13	18	11
10:15 PM	6	3	0	0	9		
10:30 PM	4	1	0	0	5		
10:45 PM	3	0	0	0	3		
11:00 PM	2	9	0	3	14	11	22
11:15 PM	4	3	0	0	7		
11:30 PM	5	7	1	0	13		
11:45 PM	0	3	0	0	3		
12:00 AM	0	4	0	0	4	11	28
12:15 AM	4	10	0	4	18		
12:30 AM	2	11	1	2	16		
12:45 AM	5	3	0	0	8		
1:00 AM	11	2	1	0	14	32	12
1:15 AM	6	3	0	0	9		
1:30 AM	12	5	1	0	18		
1:45 AM	3	2	0	0	5		
2:00 PM	4	6	0	1	11	18	22
2:15 PM	8	6	1	1	16		
2:30 PM	3	3	0	0	6		
2:45 PM	3	7	0	0	10		
3:00 PM	4	5	1	0	10	17	23
3:15 PM	9	6	2	2	19		
3:30 PM	1	7	0	1	9		
3:45 PM	3	5	0	1	9		
4:00 PM	2	8	1	1	12	9	25
4:15 PM	5	6	1	1	13		
4:30 PM	2	6	0	1	9		
4:45 PM	0	5	0	0	5		
5:00 PM	0	12	0	3	15	4	24
5:15 PM	0	5	0	1	6		
5:30 PM	3	2	1	0	6		
5:45 PM	1	5	0	0	6		
6:00 PM	0	2	0	0	2	2	3
6:15 PM	0	0	0	0	0		
6:30 PM	1	0	0	0	1		
6:45 PM	1	1	0	0	2		
7:00 PM	0	1	0	0	1	1	2
7:15 PM	1	1	0	0	2		
7:30 PM	0	0	0	0	0		
7:45 PM	0	0	0	0	0		
8:00 PM	1	0	0	0	1	4	0
8:15 PM	2	0	0	0	2		
8:30 PM	0	0	0	0	0		
8:45 PM	1	0	0	0	1		
9:00 PM	0	0	0	0	0	0	0
9:15 PM	0	0	0	0	0		
9:30 PM	0	0	0	0	0		
9:45 PM	0	0	0	0	0		
10:00 PM	0	0	0	0	0	0	0
10:15 PM	0	0	0	0	0		
10:30 PM	0	0	0	0	0		
10:45 PM	0	0	0	0	0		
11:00 PM	0	0	0	0	0	0	0
11:15 PM	0	0	0	0	0		
11:30 PM	0	0	0	0	0		
11:45 PM	0	0	0	0	0		
<b>Grand Totals</b>	<b>190</b>	<b>187</b>	<b>15</b>	<b>25</b>	<b>417</b>		

### Pedestrian Study

Location: 520 Building Elevator Parking Garage Entrance Underground/N/O N Prospect Ave

City: Redondo Beach

Date: 10/22/2019

Day: Tuesday

TIME	Peds				TOTAL	INS	OUTS
	Individual Peds		Groups				
	In	Out	In	Out			
12:00 AM	0	0	0	0	0	0	0
12:15 AM	0	0	0	0	0		
12:30 AM	0	0	0	0	0		
12:45 AM	0	0	0	0	0		
1:00 AM	0	0	0	0	0	0	0
1:15 AM	0	0	0	0	0		
1:30 AM	0	0	0	0	0		
1:45 AM	0	0	0	0	0		
2:00 AM	0	0	0	0	0	0	0
2:15 AM	0	0	0	0	0		
2:30 AM	0	0	0	0	0		
2:45 AM	0	0	0	0	0		
3:00 AM	0	0	0	0	0	1	0
3:15 AM	1	0	0	0	1		
3:30 AM	0	0	0	0	0		
3:45 AM	0	0	0	0	0		
4:00 AM	0	0	0	0	0	0	0
4:15 AM	0	0	0	0	0		
4:30 AM	0	0	0	0	0		
4:45 AM	0	0	0	0	0		
5:00 AM	0	0	0	0	0	0	0
5:15 AM	0	0	0	0	0		
5:30 AM	0	0	0	0	0		
5:45 AM	0	0	0	0	0		
6:00 AM	0	0	0	0	0	2	0
6:15 AM	0	0	0	0	0		
6:30 AM	1	0	0	0	1		
6:45 AM	1	0	0	0	1		
7:00 AM	3	0	0	0	3	14	2
7:15 AM	0	0	0	0	0		
7:30 AM	4	1	0	0	5		
7:45 AM	7	1	1	0	9		
8:00 AM	7	0	1	0	8	38	5
8:15 AM	6	0	1	0	7		
8:30 AM	13	1	3	0	17		
8:45 AM	12	4	3	2	21		
9:00 AM	5	1	2	0	8	14	10
9:15 AM	0	0	0	0	0		
9:30 AM	3	5	1	0	9		
9:45 AM	6	4	0	0	10		
10:00 PM	4	5	0	1	10	14	20
10:15 PM	2	2	0	0	4		
10:30 PM	4	8	0	1	13		
10:45 PM	4	5	1	1	11		
11:00 PM	4	5	1	0	10	14	17
11:15 PM	8	7	2	2	19		
11:30 PM	1	2	0	0	3		
11:45 PM	1	3	0	0	4		
12:00 AM	2	9	0	1	12	14	24
12:15 AM	0	2	0	0	2		
12:30 AM	6	9	0	1	16		
12:45 AM	6	4	0	0	10		
1:00 AM	6	4	0	0	10	23	10
1:15 AM	7	3	0	0	10		
1:30 AM	3	1	1	0	5		
1:45 AM	7	2	2	0	11		
2:00 PM	6	3	1	0	10	22	19
2:15 PM	9	4	2	1	16		
2:30 PM	4	2	1	1	8		
2:45 PM	3	10	0	2	15		
3:00 PM	5	6	1	2	14	12	18
3:15 PM	4	8	1	2	15		
3:30 PM	1	0	0	0	1		
3:45 PM	2	4	1	1	8		
4:00 PM	2	1	1	0	4	5	9
4:15 PM	2	3	0	1	6		
4:30 PM	1	1	0	0	2		
4:45 PM	0	4	0	0	4		
5:00 PM	0	3	0	0	3	2	15
5:15 PM	0	6	0	1	7		
5:30 PM	0	2	0	0	2		
5:45 PM	2	4	0	0	6		
6:00 PM	1	3	0	0	4	1	4
6:15 PM	0	0	0	0	0		
6:30 PM	0	0	0	0	0		
6:45 PM	0	1	0	0	1		
7:00 PM	0	1	0	0	1	5	5
7:15 PM	1	0	0	0	1		
7:30 PM	4	3	1	1	9		
7:45 PM	0	1	0	0	1		
8:00 PM	1	0	0	0	1	2	0
8:15 PM	0	0	0	0	0		
8:30 PM	1	0	0	0	1		
8:45 PM	0	0	0	0	0		
9:00 PM	0	0	0	0	0	1	0
9:15 PM	1	0	0	0	1		
9:30 PM	0	0	0	0	0		
9:45 PM	0	0	0	0	0		
10:00 PM	0	0	0	0	0	0	0
10:15 PM	0	0	0	0	0		
10:30 PM	0	0	0	0	0		
10:45 PM	0	0	0	0	0		
11:00 PM	0	0	0	0	0	0	0
11:15 PM	0	0	0	0	0		
11:30 PM	0	0	0	0	0		
11:45 PM	0	0	0	0	0		
<b>Grand Totals</b>	<b>184</b>	<b>158</b>	<b>28</b>	<b>21</b>	<b>391</b>		

### Pedestrian Study

Location: 520 Building Elevator Parking Garage Entrance Underground/N/O N Prospect Ave

City: Redondo Beach

Date: 10/22/2019

Day: Tuesday

TIME	Peds				TOTAL	INS	OUTS
	Individual Peds		Groups				
	In	Out	In	Out			
12:00 AM	0	0	0	0	0	0	0
12:15 AM	0	0	0	0	0		
12:30 AM	0	0	0	0	0		
12:45 AM	0	0	0	0	0		
1:00 AM	0	0	0	0	0	0	0
1:15 AM	0	0	0	0	0		
1:30 AM	0	0	0	0	0		
1:45 AM	0	0	0	0	0		
2:00 AM	0	0	0	0	0	0	0
2:15 AM	0	0	0	0	0		
2:30 AM	0	0	0	0	0		
2:45 AM	0	0	0	0	0		
3:00 AM	0	0	0	0	0	0	0
3:15 AM	0	0	0	0	0		
3:30 AM	0	0	0	0	0		
3:45 AM	0	0	0	0	0		
4:00 AM	0	0	0	0	0	0	0
4:15 AM	0	0	0	0	0		
4:30 AM	0	0	0	0	0		
4:45 AM	0	0	0	0	0		
5:00 AM	0	0	0	0	0	0	0
5:15 AM	0	0	0	0	0		
5:30 AM	0	0	0	0	0		
5:45 AM	0	0	0	0	0		
6:00 AM	1	0	0	0	1	8	0
6:15 AM	0	0	0	0	0		
6:30 AM	4	0	0	0	4		
6:45 AM	3	0	0	0	3		
7:00 AM	1	0	0	0	1	10	2
7:15 AM	2	1	0	0	3		
7:30 AM	4	1	0	0	5		
7:45 AM	3	0	0	0	3		
8:00 AM	4	0	0	0	4	10	1
8:15 AM	4	1	0	0	5		
8:30 AM	0	0	0	0	0		
8:45 AM	2	0	0	0	2		
9:00 AM	4	0	0	0	4	13	3
9:15 AM	4	2	0	0	6		
9:30 AM	3	0	0	0	3		
9:45 AM	2	1	0	0	3		
10:00 PM	6	2	0	0	8	16	8
10:15 PM	5	2	0	0	7		
10:30 PM	2	3	0	1	6		
10:45 PM	3	1	0	0	4		
11:00 PM	5	8	0	1	14	8	22
11:15 PM	1	4	0	0	5		
11:30 PM	1	4	0	0	5		
11:45 PM	1	6	0	0	7		
12:00 AM	0	8	0	1	9	11	22
12:15 AM	1	2	0	1	3		
12:30 AM	7	7	1	1	16		
12:45 AM	3	5	0	0	8		
1:00 AM	1	1	0	0	2	10	6
1:15 AM	3	1	1	0	5		
1:30 AM	3	1	0	0	4		
1:45 AM	3	3	1	0	7		
2:00 PM	1	2	0	0	3	5	8
2:15 PM	2	2	0	0	4		
2:30 PM	1	3	0	0	4		
2:45 PM	1	1	0	0	2		
3:00 PM	1	1	0	0	2	3	3
3:15 PM	1	0	0	0	1		
3:30 PM	1	2	0	0	3		
3:45 PM	0	0	0	0	0		
4:00 PM	0	5	0	0	5	0	10
4:15 PM	0	2	0	0	2		
4:30 PM	0	2	0	0	2		
4:45 PM	0	1	0	0	1		
5:00 PM	0	6	0	1	7	0	14
5:15 PM	0	3	0	0	3		
5:30 PM	0	2	0	0	2		
5:45 PM	0	3	0	0	3		
6:00 PM	0	2	0	0	2	0	5
6:15 PM	0	1	0	0	1		
6:30 PM	0	2	0	1	3		
6:45 PM	0	0	0	0	0		
7:00 PM	0	0	0	0	0	0	1
7:15 PM	0	0	0	0	0		
7:30 PM	0	0	0	0	0		
7:45 PM	0	1	0	0	1		
8:00 PM	0	0	0	0	0	0	0
8:15 PM	0	0	0	0	0		
8:30 PM	0	0	0	0	0		
8:45 PM	0	0	0	0	0		
9:00 PM	0	0	0	0	0	0	0
9:15 PM	0	0	0	0	0		
9:30 PM	0	0	0	0	0		
9:45 PM	0	0	0	0	0		
10:00 PM	0	0	0	0	0	0	0
10:15 PM	0	0	0	0	0		
10:30 PM	0	0	0	0	0		
10:45 PM	0	0	0	0	0		
11:00 PM	0	0	0	0	0	0	0
11:15 PM	0	0	0	0	0		
11:30 PM	0	0	0	0	0		
11:45 PM	0	0	0	0	0		
<b>Grand Totals</b>	<b>94</b>	<b>105</b>	<b>3</b>	<b>6</b>	<b>208</b>		

### Pedestrian Study

Location: 520 Building Elevator Parking Garage Entrance Underground/N/O N Prospect Ave

City: Redondo Beach

Date: 10/22/2019

Day: Tuesday

TIME	Peds				TOTAL	INS	OUTS
	Individual Peds		Groups				
	In	Out	In	Out			
12:00 AM	0	0	0	0	0	0	0
12:15 AM	0	0	0	0	0		
12:30 AM	0	0	0	0	0		
12:45 AM	0	0	0	0	0		
1:00 AM	0	0	0	0	0	0	0
1:15 AM	0	0	0	0	0		
1:30 AM	0	0	0	0	0		
1:45 AM	0	0	0	0	0		
2:00 AM	0	0	0	0	0	0	0
2:15 AM	0	0	0	0	0		
2:30 AM	0	0	0	0	0		
2:45 AM	0	0	0	0	0		
3:00 AM	0	0	0	0	0	0	0
3:15 AM	0	0	0	0	0		
3:30 AM	0	0	0	0	0		
3:45 AM	0	0	0	0	0		
4:00 AM	0	0	0	0	0	0	0
4:15 AM	0	0	0	0	0		
4:30 AM	0	0	0	0	0		
4:45 AM	0	0	0	0	0		
5:00 AM	0	0	0	0	0	0	0
5:15 AM	0	0	0	0	0		
5:30 AM	0	0	0	0	0		
5:45 AM	0	0	0	0	0		
6:00 AM	0	0	0	0	0	2	0
6:15 AM	0	0	0	0	0		
6:30 AM	2	0	0	0	2		
6:45 AM	0	0	0	0	0		
7:00 AM	0	0	0	0	0	11	0
7:15 AM	5	0	0	0	5		
7:30 AM	1	0	0	0	1		
7:45 AM	5	0	0	0	5		
8:00 AM	6	1	0	0	7	14	1
8:15 AM	2	0	0	0	2		
8:30 AM	2	0	0	0	2		
8:45 AM	4	0	0	0	4		
9:00 AM	11	0	2	0	13	31	10
9:15 AM	2	4	0	1	7		
9:30 AM	12	2	2	0	16		
9:45 AM	6	4	0	1	11		
10:00 PM	6	4	1	1	12	25	24
10:15 PM	6	7	0	2	15		
10:30 PM	3	11	1	3	18		
10:45 PM	10	2	1	0	13		
11:00 PM	3	6	1	0	10	6	23
11:15 PM	1	3	0	1	5		
11:30 PM	2	5	0	1	8		
11:45 PM	0	9	0	1	10		
12:00 AM	0	3	0	0	3	11	13
12:15 AM	3	6	1	0	10		
12:30 AM	3	2	0	0	5		
12:45 AM	5	2	0	0	7		
1:00 AM	2	2	0	0	4	6	5
1:15 AM	2	0	1	0	3		
1:30 AM	1	3	0	0	4		
1:45 AM	1	0	0	0	1		
2:00 PM	2	1	0	0	3	6	4
2:15 PM	1	1	0	0	2		
2:30 PM	2	2	0	0	4		
2:45 PM	1	0	0	0	1		
3:00 PM	2	1	0	0	3	4	5
3:15 PM	2	0	0	0	2		
3:30 PM	0	2	0	0	2		
3:45 PM	0	2	0	0	2		
4:00 PM	1	0	0	0	1	2	10
4:15 PM	1	1	0	0	2		
4:30 PM	0	5	0	1	6		
4:45 PM	0	4	0	0	4		
5:00 PM	0	6	0	0	6	1	12
5:15 PM	0	2	0	0	2		
5:30 PM	0	2	0	0	2		
5:45 PM	1	2	0	0	3		
6:00 PM	0	2	0	0	2	0	4
6:15 PM	0	2	0	0	2		
6:30 PM	0	0	0	0	0		
6:45 PM	0	0	0	0	0		
7:00 PM	0	0	0	0	0	1	2
7:15 PM	1	1	0	0	2		
7:30 PM	0	0	0	0	0		
7:45 PM	0	1	0	0	1		
8:00 PM	1	1	0	0	2	1	1
8:15 PM	0	0	0	0	0		
8:30 PM	0	0	0	0	0		
8:45 PM	0	0	0	0	0		
9:00 PM	0	0	0	0	0	0	0
9:15 PM	0	0	0	0	0		
9:30 PM	0	0	0	0	0		
9:45 PM	0	0	0	0	0		
10:00 PM	0	0	0	0	0	0	0
10:15 PM	0	0	0	0	0		
10:30 PM	0	0	0	0	0		
10:45 PM	0	0	0	0	0		
11:00 PM	0	0	0	0	0	0	0
11:15 PM	0	0	0	0	0		
11:30 PM	0	0	0	0	0		
11:45 PM	0	0	0	0	0		
<b>Grand Totals</b>	<b>121</b>	<b>114</b>	<b>10</b>	<b>12</b>	<b>257</b>		

### Pedestrian Study

Location: 520 Side Entrance (Key Card Only) N/O N Prospect Ave

City: Redondo Beach

Date: 10/22/2019

Day: Tuesday

TIME	Peds				TOTAL	INS	OUTS
	Individual Peds		Groups				
	In	Out	In	Out			
12:00 AM	0	0	0	0	0	0	0
12:15 AM	0	0	0	0	0	0	0
12:30 AM	0	0	0	0	0	0	0
12:45 AM	0	0	0	0	0	0	0
1:00 AM	0	0	0	0	0	0	0
1:15 AM	0	0	0	0	0	0	0
1:30 AM	0	0	0	0	0	0	0
1:45 AM	0	0	0	0	0	0	0
2:00 AM	0	0	0	0	0	0	0
2:15 AM	0	0	0	0	0	0	0
2:30 AM	0	0	0	0	0	0	0
2:45 AM	0	0	0	0	0	0	0
3:00 AM	0	0	0	0	0	0	0
3:15 AM	0	0	0	0	0	0	0
3:30 AM	0	0	0	0	0	0	0
3:45 AM	0	0	0	0	0	0	0
4:00 AM	0	0	0	0	0	0	0
4:15 AM	0	0	0	0	0	0	0
4:30 AM	0	0	0	0	0	0	0
4:45 AM	0	0	0	0	0	0	0
5:00 AM	0	0	0	0	0	0	0
5:15 AM	0	0	0	0	0	0	0
5:30 AM	0	0	0	0	0	0	0
5:45 AM	0	0	0	0	0	0	0
6:00 AM	0	0	0	0	0	0	0
6:15 AM	0	0	0	0	0	0	0
6:30 AM	0	0	0	0	0	0	0
6:45 AM	0	0	0	0	0	0	0
7:00 AM	0	0	0	0	0	0	0
7:15 AM	0	0	0	0	0	0	0
7:30 AM	0	0	0	0	0	0	0
7:45 AM	0	0	0	0	0	0	0
8:00 AM	0	0	0	0	0	0	0
8:15 AM	0	0	0	0	0	0	0
8:30 AM	0	0	0	0	0	0	0
8:45 AM	0	0	0	0	0	0	0
9:00 AM	0	0	0	0	0	0	0
9:15 AM	0	0	0	0	0	0	0
9:30 AM	0	0	0	0	0	0	0
9:45 AM	0	0	0	0	0	0	0
10:00 PM	0	0	0	0	0	0	4
10:15 PM	0	2	0	0	2	0	0
10:30 PM	0	1	0	0	1	0	0
10:45 PM	0	1	0	0	1	0	0
11:00 PM	0	0	0	0	0	1	3
11:15 PM	0	1	0	0	1	0	0
11:30 PM	1	1	0	0	2	0	0
11:45 PM	0	1	0	0	1	0	0
12:00 AM	1	2	0	0	3	1	3
12:15 AM	0	0	0	0	0	0	0
12:30 AM	0	0	0	0	0	0	0
12:45 AM	0	1	0	0	1	0	0
1:00 AM	0	0	0	0	0	0	1
1:15 AM	0	0	0	0	0	0	0
1:30 AM	0	1	0	0	1	0	0
1:45 AM	0	0	0	0	0	0	0
2:00 PM	0	0	0	0	0	0	2
2:15 PM	0	2	0	0	2	0	0
2:30 PM	0	0	0	0	0	0	0
2:45 PM	0	0	0	0	0	0	0
3:00 PM	0	0	0	0	0	0	2
3:15 PM	0	2	0	0	2	0	0
3:30 PM	0	0	0	0	0	0	0
3:45 PM	0	0	0	0	0	0	0
4:00 PM	0	1	0	0	1	0	1
4:15 PM	0	0	0	0	0	0	0
4:30 PM	0	0	0	0	0	0	0
4:45 PM	0	0	0	0	0	0	0
5:00 PM	0	1	0	0	1	0	1
5:15 PM	0	0	0	0	0	0	0
5:30 PM	0	0	0	0	0	0	0
5:45 PM	0	0	0	0	0	0	0
6:00 PM	0	0	0	0	0	0	0
6:15 PM	0	0	0	0	0	0	0
6:30 PM	0	0	0	0	0	0	0
6:45 PM	0	0	0	0	0	0	0
7:00 PM	0	0	0	0	0	1	1
7:15 PM	0	0	0	0	0	0	0
7:30 PM	1	1	0	0	2	0	0
7:45 PM	0	0	0	0	0	0	0
8:00 PM	0	0	0	0	0	0	0
8:15 PM	0	0	0	0	0	0	0
8:30 PM	0	0	0	0	0	0	0
8:45 PM	0	0	0	0	0	0	0
9:00 PM	0	0	0	0	0	0	0
9:15 PM	0	0	0	0	0	0	0
9:30 PM	0	0	0	0	0	0	0
9:45 PM	0	0	0	0	0	0	0
10:00 PM	0	0	0	0	0	0	0
10:15 PM	0	0	0	0	0	0	0
10:30 PM	0	0	0	0	0	0	0
10:45 PM	0	0	0	0	0	0	0
11:00 PM	0	0	0	0	0	0	0
11:15 PM	0	0	0	0	0	0	0
11:30 PM	0	0	0	0	0	0	0
11:45 PM	0	0	0	0	0	0	0
<b>Grand Totals</b>	<b>3</b>	<b>18</b>	<b>0</b>	<b>0</b>	<b>21</b>		



### Pedestrian Study

Location: 514 Side Entrance (Key Card Only) N/O N Prospect Ave

City: Redondo Beach

Date: 10/22/2019

Day: Tuesday

TIME	Peds				TOTAL	INS	OUTS
	Individual Peds		Groups				
	In	Out	In	Out			
12:00 AM	0	0	0	0	0	0	0
12:15 AM	0	0	0	0	0		
12:30 AM	0	0	0	0	0		
12:45 AM	0	0	0	0	0		
1:00 AM	0	0	0	0	0	1	0
1:15 AM	0	0	0	0	0		
1:30 AM	1	0	0	0	1		
1:45 AM	0	0	0	0	0		
2:00 AM	0	0	0	0	0	1	0
2:15 AM	0	0	0	0	0		
2:30 AM	1	0	0	0	1		
2:45 AM	0	0	0	0	0		
3:00 AM	0	0	0	0	0	2	0
3:15 AM	1	0	0	0	1		
3:30 AM	1	0	0	0	1		
3:45 AM	0	0	0	0	0		
4:00 AM	0	0	0	0	0	3	0
4:15 AM	0	0	0	0	0		
4:30 AM	0	0	0	0	0		
4:45 AM	3	0	1	0	4		
5:00 AM	1	0	0	0	1	12	1
5:15 AM	4	1	0	0	5		
5:30 AM	6	0	0	0	6		
5:45 AM	1	0	0	0	1		
6:00 AM	3	1	0	0	4	25	14
6:15 AM	7	4	1	1	13		
6:30 AM	7	3	0	0	10		
6:45 AM	8	6	0	0	14		
7:00 AM	6	3	0	0	9	28	16
7:15 AM	15	3	1	0	19		
7:30 AM	3	4	0	0	7		
7:45 AM	4	6	0	1	11		
8:00 AM	7	7	0	0	14	42	31
8:15 AM	8	4	1	0	13		
8:30 AM	11	6	1	0	18		
8:45 AM	16	14	0	4	34		
9:00 AM	12	8	1	1	22	49	31
9:15 AM	9	6	1	0	16		
9:30 AM	17	3	4	0	24		
9:45 AM	11	14	3	2	30		
10:00 PM	12	9	1	2	24	52	56
10:15 PM	11	24	2	5	42		
10:30 PM	12	10	2	1	25		
10:45 PM	17	13	3	2	35		
11:00 PM	10	18	1	4	33	35	55
11:15 PM	10	7	1	2	20		
11:30 PM	8	15	1	1	25		
11:45 PM	7	15	0	3	25		
12:00 AM	3	16	0	3	22	26	48
12:15 AM	5	16	0	1	22		
12:30 AM	5	10	0	2	17		
12:45 AM	13	6	2	0	21		
1:00 AM	9	10	1	1	21	35	30
1:15 AM	9	5	2	0	16		
1:30 AM	9	5	3	0	17		
1:45 AM	8	10	1	2	21		
2:00 PM	6	14	1	4	25	30	35
2:15 PM	12	4	0	0	16		
2:30 PM	4	6	0	0	10		
2:45 PM	8	11	2	2	23		
3:00 PM	3	12	0	2	17	24	44
3:15 PM	4	7	0	2	13		
3:30 PM	9	12	2	2	25		
3:45 PM	8	13	2	2	25		
4:00 PM	4	1	0	0	5	21	14
4:15 PM	1	6	0	0	7		
4:30 PM	10	4	0	1	15		
4:45 PM	6	3	0	1	10		
5:00 PM	4	8	0	1	13	22	22
5:15 PM	10	5	1	0	16		
5:30 PM	5	2	0	0	7		
5:45 PM	3	7	0	1	11		
6:00 PM	5	14	1	3	23	27	34
6:15 PM	8	9	1	0	18		
6:30 PM	4	6	0	0	10		
6:45 PM	10	5	1	0	16		
7:00 PM	2	4	0	0	6	12	22
7:15 PM	5	7	1	1	14		
7:30 PM	4	8	0	1	13		
7:45 PM	1	3	0	0	4		
8:00 PM	1	22	0	7	30	1	28
8:15 PM	0	1	0	0	1		
8:30 PM	0	3	0	1	4		
8:45 PM	0	2	0	0	2		
9:00 PM	0	1	0	0	1	0	1
9:15 PM	0	0	0	0	0		
9:30 PM	0	0	0	0	0		
9:45 PM	0	0	0	0	0		
10:00 PM	0	0	0	0	0	0	0
10:15 PM	0	0	0	0	0		
10:30 PM	0	0	0	0	0		
10:45 PM	0	0	0	0	0		
11:00 PM	0	0	0	0	0	0	0
11:15 PM	0	0	0	0	0		
11:30 PM	0	0	0	0	0		
11:45 PM	0	0	0	0	0		
<b>Grand Totals</b>	<b>448</b>	<b>482</b>	<b>46</b>	<b>69</b>	<b>1045</b>		

### Pedestrian Study

Location: Patients/Visitors-Ucla Health Entrance/N/O N Prospect Ave

City: Redondo Beach

Date: 10/22/2019

Day: Tuesday

TIME	Peds				TOTAL	INS	OUTS
	Individual Peds		Groups				
	In	Out	In	Out			
12:00 AM	0	0	0	0	0	0	0
12:15 AM	0	0	0	0	0		
12:30 AM	0	0	0	0	0		
12:45 AM	0	0	0	0	0		
1:00 AM	0	0	0	0	0	0	0
1:15 AM	0	0	0	0	0		
1:30 AM	0	0	0	0	0		
1:45 AM	0	0	0	0	0		
2:00 AM	0	0	0	0	0	0	0
2:15 AM	0	0	0	0	0		
2:30 AM	0	0	0	0	0		
2:45 AM	0	0	0	0	0		
3:00 AM	0	0	0	0	0	0	0
3:15 AM	0	0	0	0	0		
3:30 AM	0	0	0	0	0		
3:45 AM	0	0	0	0	0		
4:00 AM	0	0	0	0	0	0	0
4:15 AM	0	0	0	0	0		
4:30 AM	0	0	0	0	0		
4:45 AM	0	0	0	0	0		
5:00 AM	0	0	0	0	0	0	0
5:15 AM	0	0	0	0	0		
5:30 AM	0	0	0	0	0		
5:45 AM	0	0	0	0	0		
6:00 AM	0	0	0	0	0	0	0
6:15 AM	0	0	0	0	0		
6:30 AM	0	0	0	0	0		
6:45 AM	0	0	0	0	0		
7:00 AM	1	0	0	0	1	24	1
7:15 AM	1	0	0	0	1		
7:30 AM	4	0	0	0	4		
7:45 AM	18	1	2	0	21		
8:00 AM	8	0	0	0	8	29	9
8:15 AM	9	2	2	1	14		
8:30 AM	4	5	0	1	10		
8:45 AM	8	2	1	0	11		
9:00 AM	1	6	0	0	7	20	28
9:15 AM	5	10	1	3	19		
9:30 AM	4	2	0	0	6		
9:45 AM	10	10	0	3	23		
10:00 PM	3	7	0	1	11	39	25
10:15 PM	13	6	2	0	21		
10:30 PM	15	10	3	3	31		
10:45 PM	8	2	2	0	12		
11:00 PM	4	3	0	1	8	27	18
11:15 PM	7	5	0	1	13		
11:30 PM	6	3	0	0	9		
11:45 PM	10	7	0	0	17		
12:00 AM	3	3	1	0	7	24	12
12:15 AM	4	2	1	0	7		
12:30 AM	5	4	0	0	9		
12:45 AM	12	3	0	0	15		
1:00 AM	4	4	0	0	8	24	19
1:15 AM	5	5	1	1	12		
1:30 AM	7	2	0	0	9		
1:45 AM	8	8	0	1	17		
2:00 PM	12	2	4	0	18	27	16
2:15 PM	8	2	2	0	12		
2:30 PM	3	9	0	2	14		
2:45 PM	4	3	1	1	9		
3:00 PM	6	5	1	1	13	34	29
3:15 PM	11	8	2	2	23		
3:30 PM	7	8	0	1	16		
3:45 PM	10	8	3	1	22		
4:00 PM	9	4	1	2	16	29	25
4:15 PM	9	6	2	0	17		
4:30 PM	5	8	0	0	13		
4:45 PM	6	7	0	1	14		
5:00 PM	3	9	0	2	14	7	23
5:15 PM	1	8	0	1	10		
5:30 PM	2	4	0	0	6		
5:45 PM	1	2	0	0	3		
6:00 PM	3	0	1	0	4	9	7
6:15 PM	3	3	1	0	7		
6:30 PM	3	0	1	0	4		
6:45 PM	0	4	0	1	5		
7:00 PM	1	1	0	0	2	6	7
7:15 PM	2	0	0	0	2		
7:30 PM	2	2	0	0	4		
7:45 PM	1	4	0	1	6		
8:00 PM	0	0	0	0	0	6	10
8:15 PM	2	1	1	0	4		
8:30 PM	0	0	0	0	0		
8:45 PM	4	9	1	1	15		
9:00 PM	0	0	0	0	0	0	1
9:15 PM	0	0	0	0	0		
9:30 PM	0	1	0	0	1		
9:45 PM	0	0	0	0	0		
10:00 PM	0	0	0	0	0	0	0
10:15 PM	0	0	0	0	0		
10:30 PM	0	0	0	0	0		
10:45 PM	0	0	0	0	0		
11:00 PM	0	0	0	0	0	0	0
11:15 PM	0	0	0	0	0		
11:30 PM	0	0	0	0	0		
11:45 PM	0	0	0	0	0		
<b>Grand Totals</b>	<b>305</b>	<b>230</b>	<b>37</b>	<b>33</b>	<b>605</b>		

### Pedestrian Study

Location: Employees Only-Ucla Health Entrance N/O N Prospect Ave

City: Redondo Beach

Date: 10/22/2019

Day: Tuesday

TIME	Peds				TOTAL	INS	OUTS
	Individual Peds		Groups				
	In	Out	In	Out			
12:00 AM	0	0	0	0	0	0	0
12:15 AM	0	0	0	0	0		
12:30 AM	0	0	0	0	0		
12:45 AM	0	0	0	0	0		
1:00 AM	0	0	0	0	0	0	0
1:15 AM	0	0	0	0	0		
1:30 AM	0	0	0	0	0		
1:45 AM	0	0	0	0	0		
2:00 AM	0	0	0	0	0	0	0
2:15 AM	0	0	0	0	0		
2:30 AM	0	0	0	0	0		
2:45 AM	0	0	0	0	0		
3:00 AM	0	0	0	0	0	0	0
3:15 AM	0	0	0	0	0		
3:30 AM	0	0	0	0	0		
3:45 AM	0	0	0	0	0		
4:00 AM	0	0	0	0	0	0	0
4:15 AM	0	0	0	0	0		
4:30 AM	0	0	0	0	0		
4:45 AM	0	0	0	0	0		
5:00 AM	0	0	0	0	0	0	0
5:15 AM	0	0	0	0	0		
5:30 AM	0	0	0	0	0		
5:45 AM	0	0	0	0	0		
6:00 AM	0	0	0	0	0	0	0
6:15 AM	0	0	0	0	0		
6:30 AM	0	0	0	0	0		
6:45 AM	0	0	0	0	0		
7:00 AM	0	0	0	0	0	5	1
7:15 AM	2	0	0	0	2		
7:30 AM	3	1	0	0	4		
7:45 AM	0	0	0	0	0		
8:00 AM	2	1	0	0	3	3	5
8:15 AM	0	2	0	0	2		
8:30 AM	1	1	0	0	2		
8:45 AM	0	1	0	0	1		
9:00 AM	1	0	0	0	1	4	5
9:15 AM	0	1	0	0	1		
9:30 AM	1	2	0	0	3		
9:45 AM	2	2	0	0	4		
10:00 PM	0	2	0	1	3	2	14
10:15 PM	0	6	0	2	8		
10:30 PM	0	2	0	0	2		
10:45 PM	2	4	0	1	7		
11:00 PM	0	3	0	1	4	3	18
11:15 PM	0	2	0	0	2		
11:30 PM	2	6	0	0	8		
11:45 PM	1	7	0	2	10		
12:00 AM	4	0	1	0	5	5	3
12:15 AM	0	1	0	0	1		
12:30 AM	1	1	0	0	2		
12:45 AM	0	1	0	0	1		
1:00 AM	0	1	0	0	1	2	5
1:15 AM	0	2	0	0	2		
1:30 AM	2	2	0	0	4		
1:45 AM	0	0	0	0	0		
2:00 PM	1	3	0	1	5	2	12
2:15 PM	1	2	0	0	3		
2:30 PM	0	3	0	1	4		
2:45 PM	0	4	0	1	5		
3:00 PM	1	3	0	0	4	2	12
3:15 PM	0	3	0	0	3		
3:30 PM	0	3	0	1	4		
3:45 PM	1	3	0	1	5		
4:00 PM	0	2	0	0	2	2	11
4:15 PM	0	1	0	0	1		
4:30 PM	0	1	0	0	1		
4:45 PM	2	7	0	1	10		
5:00 PM	1	4	0	0	5	1	5
5:15 PM	0	1	0	0	1		
5:30 PM	0	0	0	0	0		
5:45 PM	0	0	0	0	0		
6:00 PM	0	1	0	0	1	0	1
6:15 PM	0	0	0	0	0		
6:30 PM	0	0	0	0	0		
6:45 PM	0	0	0	0	0		
7:00 PM	0	0	0	0	0	2	2
7:15 PM	0	0	0	0	0		
7:30 PM	0	1	0	0	1		
7:45 PM	2	1	0	0	3		
8:00 PM	1	1	0	0	2	3	4
8:15 PM	0	1	0	0	1		
8:30 PM	1	1	0	0	2		
8:45 PM	1	1	0	0	2		
9:00 PM	0	3	0	1	4	0	3
9:15 PM	0	0	0	0	0		
9:30 PM	0	0	0	0	0		
9:45 PM	0	0	0	0	0		
10:00 PM	0	0	0	0	0	0	0
10:15 PM	0	0	0	0	0		
10:30 PM	0	0	0	0	0		
10:45 PM	0	0	0	0	0		
11:00 PM	0	0	0	0	0	0	0
11:15 PM	0	0	0	0	0		
11:30 PM	0	0	0	0	0		
11:45 PM	0	0	0	0	0		
<b>Grand Totals</b>	<b>36</b>	<b>101</b>	<b>1</b>	<b>14</b>	<b>152</b>		

### Pedestrian Study

Location: The Beach Cities Surgery Center-Ucla Health Entrance N/O N Prospect Ave  
 City: Redondo Beach

Date: 10/22/2019  
 Day: Tuesday

TIME	Beach Cities Surgery Center Entrance					UCLA Health Entrance					INS	OUTS
	Individual Peds		Groups		TOTAL	Individual Peds		Groups		TOTAL		
	In	Out	In	Out		In	Out	In	Out			
12:00 AM	0	0	0	0	0	0	0	0	0	0	0	0
12:15 AM	0	0	0	0	0	0	0	0	0	0	0	0
12:30 AM	0	0	0	0	0	0	0	0	0	0	0	0
12:45 AM	0	0	0	0	0	0	0	0	0	0	0	0
1:00 AM	0	0	0	0	0	0	0	0	0	0	0	0
1:15 AM	0	0	0	0	0	0	0	0	0	0	0	0
1:30 AM	0	0	0	0	0	0	0	0	0	0	0	0
1:45 AM	0	0	0	0	0	0	0	0	0	0	0	0
2:00 AM	0	0	0	0	0	0	0	0	0	0	0	0
2:15 AM	0	0	0	0	0	0	0	0	0	0	0	0
2:30 AM	0	0	0	0	0	0	0	0	0	0	0	0
2:45 AM	0	0	0	0	0	0	0	0	0	0	0	0
3:00 AM	0	0	0	0	0	0	0	0	0	0	0	0
3:15 AM	0	0	0	0	0	0	0	0	0	0	0	0
3:30 AM	0	0	0	0	0	0	0	0	0	0	0	0
3:45 AM	0	0	0	0	0	0	0	0	0	0	0	0
4:00 AM	0	0	0	0	0	0	0	0	0	0	0	0
4:15 AM	0	0	0	0	0	0	0	0	0	0	0	0
4:30 AM	0	0	0	0	0	0	0	0	0	0	0	0
4:45 AM	0	0	0	0	0	0	0	0	0	0	0	0
5:00 AM	0	0	0	0	0	0	0	0	0	0	0	0
5:15 AM	0	0	0	0	0	0	0	0	0	0	0	0
5:30 AM	0	0	0	0	0	0	0	0	0	0	0	0
5:45 AM	0	0	0	0	0	0	0	0	0	0	0	0
6:00 AM	1	0	0	0	1	0	0	0	0	0	5	2
6:15 AM	3	2	1	0	6	0	0	0	0	0	0	0
6:30 AM	0	0	0	0	0	0	0	0	0	0	0	0
6:45 AM	1	0	0	0	1	0	0	0	0	0	0	0
7:00 AM	0	1	0	0	1	0	0	0	0	0	3	1
7:15 AM	1	0	0	0	1	0	0	0	0	0	0	0
7:30 AM	0	0	0	0	0	0	0	0	0	0	0	0
7:45 AM	1	0	0	0	1	1	0	0	0	1	0	0
8:00 AM	1	0	0	0	1	3	0	0	0	3	7	1
8:15 AM	2	0	0	0	2	0	0	0	0	0	0	0
8:30 AM	0	1	0	0	1	0	0	0	0	0	0	0
8:45 AM	1	0	0	0	1	0	0	0	0	0	0	0
9:00 AM	4	2	1	1	8	0	0	0	0	0	12	4
9:15 AM	4	0	0	0	4	0	0	0	0	0	0	0
9:30 AM	4	1	1	0	6	0	0	0	0	0	0	0
9:45 AM	0	0	0	0	0	0	1	0	0	1	0	0
10:00 PM	0	1	0	0	1	0	0	0	0	0	3	7
10:15 PM	1	1	0	0	2	0	0	0	0	0	0	0
10:30 PM	0	1	0	0	1	1	2	0	0	3	0	0
10:45 PM	1	1	0	0	2	0	1	0	0	1	0	0
11:00 PM	0	1	0	0	1	1	0	0	0	1	7	6
11:15 PM	3	2	0	1	6	0	0	0	0	0	0	0
11:30 PM	0	1	0	0	1	0	0	0	0	0	0	0
11:45 PM	3	2	0	0	5	0	0	0	0	0	0	0
12:00 AM	3	5	1	2	11	0	4	0	0	4	9	12
12:15 AM	1	0	0	0	1	0	0	0	0	0	0	0
12:30 AM	1	0	0	0	1	0	1	0	0	1	0	0
12:45 AM	3	1	1	0	5	1	1	0	0	2	0	0
1:00 AM	0	0	0	0	0	1	0	0	0	1	4	5
1:15 AM	1	2	0	0	3	0	0	0	0	0	0	0
1:30 AM	2	2	0	0	4	0	0	0	0	0	0	0
1:45 AM	0	1	0	0	1	0	0	0	0	0	0	0
2:00 PM	1	1	0	0	2	0	1	0	0	1	4	6
2:15 PM	2	1	0	0	3	0	0	0	0	0	0	0
2:30 PM	0	2	0	0	2	0	0	0	0	0	0	0
2:45 PM	1	1	0	0	2	0	0	0	0	0	0	0
3:00 PM	1	0	0	0	1	0	0	0	0	0	1	2
3:15 PM	0	0	0	0	0	0	2	0	1	3	0	0
3:30 PM	0	0	0	0	0	0	0	0	0	0	0	0
3:45 PM	0	0	0	0	0	0	0	0	0	0	0	0
4:00 PM	0	0	0	0	0	0	1	0	0	1	0	3
4:15 PM	0	0	0	0	0	0	0	0	0	0	0	0
4:30 PM	0	1	0	0	1	0	1	0	0	1	0	0
4:45 PM	0	0	0	0	0	0	0	0	0	0	0	0
5:00 PM	0	0	0	0	0	0	3	0	0	3	0	5
5:15 PM	0	0	0	0	0	0	1	0	0	1	0	0
5:30 PM	0	0	0	0	0	0	1	0	0	1	0	0
5:45 PM	0	0	0	0	0	0	0	0	0	0	0	0
6:00 PM	0	0	0	0	0	0	0	0	0	0	0	0
6:15 PM	0	0	0	0	0	0	0	0	0	0	0	0
6:30 PM	0	0	0	0	0	0	0	0	0	0	0	0
6:45 PM	0	0	0	0	0	0	0	0	0	0	0	0
7:00 PM	0	0	0	0	0	1	0	0	0	1	2	2
7:15 PM	0	0	0	0	0	1	1	0	0	2	0	0
7:30 PM	0	0	0	0	0	0	0	0	0	0	0	0
7:45 PM	0	0	0	0	0	0	1	0	0	1	0	0
8:00 PM	0	0	0	0	0	0	0	0	0	0	0	0
8:15 PM	0	0	0	0	0	0	0	0	0	0	0	0
8:30 PM	0	0	0	0	0	0	0	0	0	0	0	0
8:45 PM	0	0	0	0	0	0	0	0	0	0	0	0
9:00 PM	0	0	0	0	0	0	0	0	0	0	1	0
9:15 PM	0	0	0	0	0	0	0	0	0	0	0	0
9:30 PM	0	0	0	0	0	1	0	0	0	1	0	0
9:45 PM	0	0	0	0	0	0	0	0	0	0	0	0
10:00 PM	0	0	0	0	0	0	0	0	0	0	0	0
10:15 PM	0	0	0	0	0	0	0	0	0	0	0	0
10:30 PM	0	0	0	0	0	0	0	0	0	0	0	0
10:45 PM	0	0	0	0	0	0	0	0	0	0	0	0
11:00 PM	0	0	0	0	0	0	0	0	0	0	0	1
11:15 PM	0	0	0	0	0	0	0	0	0	0	0	0
11:30 PM	0	0	0	0	0	0	0	0	0	0	0	0
11:45 PM	0	0	0	0	0	0	1	0	0	1	0	0
<b>Grand Totals</b>	<b>47</b>	<b>34</b>	<b>5</b>	<b>4</b>	<b>90</b>	<b>11</b>	<b>23</b>	<b>0</b>	<b>1</b>	<b>35</b>		

### Pedestrian Study

Location: Wellness Center Entrance/N/O N Prospect Ave

City: Redondo Beach

Date: 10/22/2019

Day: Tuesday

TIME	Peds				TOTAL	INS	OUTS
	Individual Peds		Groups				
	In	Out	In	Out			
12:00 AM	0	0	0	0	0	0	0
12:15 AM	0	0	0	0	0		
12:30 AM	0	0	0	0	0		
12:45 AM	0	0	0	0	0		
1:00 AM	0	0	0	0	0	0	0
1:15 AM	0	0	0	0	0		
1:30 AM	0	0	0	0	0		
1:45 AM	0	0	0	0	0		
2:00 AM	0	0	0	0	0	0	0
2:15 AM	0	0	0	0	0		
2:30 AM	0	0	0	0	0		
2:45 AM	0	0	0	0	0		
3:00 AM	0	0	0	0	0	0	0
3:15 AM	0	0	0	0	0		
3:30 AM	0	0	0	0	0		
3:45 AM	0	0	0	0	0		
4:00 AM	0	0	0	0	0	0	0
4:15 AM	0	0	0	0	0		
4:30 AM	0	0	0	0	0		
4:45 AM	0	0	0	0	0		
5:00 AM	0	0	0	0	0	7	1
5:15 AM	1	0	0	0	1		
5:30 AM	0	0	0	0	0		
5:45 AM	6	1	1	0	8		
6:00 AM	1	0	0	0	1	10	2
6:15 AM	3	1	0	0	4		
6:30 AM	2	1	0	0	3		
6:45 AM	4	0	0	0	4		
7:00 AM	3	3	0	0	6	29	12
7:15 AM	5	5	0	0	10		
7:30 AM	7	0	1	0	8		
7:45 AM	14	4	3	1	22		
8:00 AM	7	3	1	0	11	62	17
8:15 AM	14	1	1	0	16		
8:30 AM	13	0	0	0	13		
8:45 AM	28	13	6	1	48		
9:00 AM	11	4	1	0	16	32	30
9:15 AM	10	4	1	0	15		
9:30 AM	4	4	0	0	8		
9:45 AM	7	18	1	4	30		
10:00 PM	15	10	2	2	29	45	42
10:15 PM	13	17	0	2	32		
10:30 PM	7	9	1	1	18		
10:45 PM	10	6	1	0	17		
11:00 PM	5	9	0	0	14	15	44
11:15 PM	6	17	0	2	25		
11:30 PM	1	10	0	0	11		
11:45 PM	3	8	0	0	11		
12:00 AM	5	17	0	3	25	37	48
12:15 AM	14	13	1	2	30		
12:30 AM	10	13	2	4	29		
12:45 AM	8	5	1	1	15		
1:00 AM	8	4	1	0	13	21	20
1:15 AM	6	6	1	0	13		
1:30 AM	5	8	0	2	15		
1:45 AM	2	2	1	0	5		
2:00 PM	1	3	0	0	4	13	19
2:15 PM	5	6	0	1	12		
2:30 PM	3	2	0	0	5		
2:45 PM	4	8	1	2	15		
3:00 PM	3	3	0	0	6	9	19
3:15 PM	0	4	0	0	4		
3:30 PM	3	6	0	1	10		
3:45 PM	3	6	1	0	10		
4:00 PM	1	2	0	0	3	12	14
4:15 PM	4	3	0	0	7		
4:30 PM	4	1	0	0	5		
4:45 PM	3	8	0	2	13		
5:00 PM	1	10	0	3	14	5	23
5:15 PM	3	4	0	0	7		
5:30 PM	1	4	0	0	5		
5:45 PM	0	5	0	0	5		
6:00 PM	3	3	0	0	6	9	11
6:15 PM	3	5	0	1	9		
6:30 PM	1	2	0	0	3		
6:45 PM	2	1	0	0	3		
7:00 PM	0	2	0	1	3	1	9
7:15 PM	1	5	0	0	6		
7:30 PM	0	2	0	0	2		
7:45 PM	0	0	0	0	0		
8:00 PM	1	5	0	1	7	2	8
8:15 PM	1	1	0	0	2		
8:30 PM	0	2	0	0	2		
8:45 PM	0	0	0	0	0		
9:00 PM	0	1	0	0	1	0	1
9:15 PM	0	0	0	0	0		
9:30 PM	0	0	0	0	0		
9:45 PM	0	0	0	0	0		
10:00 PM	0	0	0	0	0	0	0
10:15 PM	0	0	0	0	0		
10:30 PM	0	0	0	0	0		
10:45 PM	0	0	0	0	0		
11:00 PM	0	0	0	0	0	0	0
11:15 PM	0	0	0	0	0		
11:30 PM	0	0	0	0	0		
11:45 PM	0	0	0	0	0		
<b>Grand Totals</b>	<b>309</b>	<b>320</b>	<b>29</b>	<b>37</b>	<b>695</b>		

### Pedestrian Study

Location: Entrance to Child Development Center/N/O N Prospect Ave

City: Redondo Beach

Date: 10/15/2019

Day: Tuesday

TIME	Peds				TOTAL	INS	OUTS
	Individual Peds		Groups				
	In	Out	In	Out			
12:00 AM	0	0	0	0	0	0	0
12:15 AM	0	0	0	0	0		
12:30 AM	0	0	0	0	0		
12:45 AM	0	0	0	0	0		
1:00 AM	0	0	0	0	0	0	0
1:15 AM	0	0	0	0	0		
1:30 AM	0	0	0	0	0		
1:45 AM	0	0	0	0	0		
2:00 AM	0	0	0	0	0	0	0
2:15 AM	0	0	0	0	0		
2:30 AM	0	0	0	0	0		
2:45 AM	0	0	0	0	0		
3:00 AM	0	0	0	0	0	0	0
3:15 AM	0	0	0	0	0		
3:30 AM	0	0	0	0	0		
3:45 AM	0	0	0	0	0		
4:00 AM	0	0	0	0	0	0	0
4:15 AM	0	0	0	0	0		
4:30 AM	0	0	0	0	0		
4:45 AM	0	0	0	0	0		
5:00 AM	0	0	0	0	0	0	0
5:15 AM	0	0	0	0	0		
5:30 AM	0	0	0	0	0		
5:45 AM	0	0	0	0	0		
6:00 AM	0	0	0	0	0	1	0
6:15 AM	0	0	0	0	0		
6:30 AM	1	0	0	0	1		
6:45 AM	0	0	0	0	0		
7:00 AM	11	7	2	1	21	31	19
7:15 AM	5	3	1	0	9		
7:30 AM	8	5	1	0	14		
7:45 AM	7	4	2	0	13		
8:00 AM	24	9	8	2	43	85	40
8:15 AM	14	11	2	2	29		
8:30 AM	27	11	8	0	46		
8:45 AM	20	9	7	0	36		
9:00 AM	21	16	4	4	45	32	27
9:15 AM	6	5	3	0	14		
9:30 AM	5	5	1	1	12		
9:45 AM	0	1	0	0	1		
10:00 PM	2	0	1	0	3	9	5
10:15 PM	4	2	1	0	7		
10:30 PM	0	1	0	0	1		
10:45 PM	3	2	1	0	6		
11:00 PM	1	4	0	1	6	2	5
11:15 PM	0	0	0	0	0		
11:30 PM	1	1	0	0	2		
11:45 PM	0	0	0	0	0		
12:00 AM	0	1	0	0	1	3	4
12:15 AM	1	0	0	0	1		
12:30 AM	0	3	0	0	3		
12:45 AM	2	0	0	0	2		
1:00 AM	0	1	0	0	1	3	3
1:15 AM	1	0	0	0	1		
1:30 AM	0	2	0	0	2		
1:45 AM	2	0	0	0	2		
2:00 PM	0	0	0	0	0	9	7
2:15 PM	5	4	0	0	9		
2:30 PM	2	3	0	0	5		
2:45 PM	2	0	1	0	3		
3:00 PM	5	6	2	2	15	18	26
3:15 PM	4	3	1	1	9		
3:30 PM	3	7	1	3	14		
3:45 PM	6	10	1	4	21		
4:00 PM	7	8	2	2	19	32	53
4:15 PM	9	9	1	4	23		
4:30 PM	8	20	0	9	37		
4:45 PM	8	16	0	8	32		
5:00 PM	4	12	0	3	19	29	43
5:15 PM	9	9	0	0	18		
5:30 PM	6	10	0	3	19		
5:45 PM	10	12	1	5	28		
6:00 PM	4	23	0	7	34	10	27
6:15 PM	1	3	0	1	5		
6:30 PM	0	0	0	0	0		
6:45 PM	5	1	2	0	8		
7:00 PM	0	0	0	0	0	0	4
7:15 PM	0	0	0	0	0		
7:30 PM	0	4	0	1	5		
7:45 PM	0	0	0	0	0		
8:00 PM	0	0	0	0	0	0	0
8:15 PM	0	0	0	0	0		
8:30 PM	0	0	0	0	0		
8:45 PM	0	0	0	0	0		
9:00 PM	0	0	0	0	0	0	0
9:15 PM	0	0	0	0	0		
9:30 PM	0	0	0	0	0		
9:45 PM	0	0	0	0	0		
10:00 PM	0	0	0	0	0	0	0
10:15 PM	0	0	0	0	0		
10:30 PM	0	0	0	0	0		
10:45 PM	0	0	0	0	0		
11:00 PM	0	0	0	0	0	0	0
11:15 PM	0	0	0	0	0		
11:30 PM	0	0	0	0	0		
11:45 PM	0	0	0	0	0		
<b>Grand Totals</b>	<b>264</b>	<b>263</b>	<b>54</b>	<b>64</b>	<b>645</b>		

### Pedestrian Study

Location: Main Entrance to 514 Building/N/O N Prospect Ave

City: Redondo Beach

Date: 10/22/2019

Day: Tuesday

TIME	Peds				TOTAL	INS	OUTS
	Individual Peds		Groups				
	In	Out	In	Out			
12:00 AM	0	0	0	0	0	0	0
12:15 AM	0	0	0	0	0		
12:30 AM	0	0	0	0	0		
12:45 AM	0	0	0	0	0		
1:00 AM	0	0	0	0	0	2	3
1:15 AM	0	0	0	0	0		
1:30 AM	2	2	0	0	4		
1:45 AM	0	1	0	0	1		
2:00 AM	0	0	0	0	0	5	0
2:15 AM	1	0	0	0	1		
2:30 AM	1	0	0	0	1		
2:45 AM	3	0	1	0	4		
3:00 AM	0	0	0	0	0	0	0
3:15 AM	0	0	0	0	0		
3:30 AM	0	0	0	0	0		
3:45 AM	0	0	0	0	0		
4:00 AM	0	0	0	0	0	2	0
4:15 AM	0	0	0	0	0		
4:30 AM	0	0	0	0	0		
4:45 AM	2	0	0	0	2		
5:00 AM	1	0	0	0	1	13	1
5:15 AM	3	1	0	0	4		
5:30 AM	3	0	0	0	3		
5:45 AM	6	0	0	0	6		
6:00 AM	8	4	1	0	13	26	14
6:15 AM	6	1	0	0	7		
6:30 AM	4	1	0	0	5		
6:45 AM	8	8	1	1	18		
7:00 AM	10	8	1	3	22	28	11
7:15 AM	5	2	0	0	7		
7:30 AM	5	1	0	0	6		
7:45 AM	8	0	1	0	9		
8:00 AM	8	5	0	0	13	71	24
8:15 AM	14	1	0	0	15		
8:30 AM	26	8	3	0	37		
8:45 AM	23	10	3	1	37		
9:00 AM	25	4	3	0	32	89	30
9:15 AM	12	4	0	0	16		
9:30 AM	27	7	4	0	38		
9:45 AM	25	15	3	2	45		
10:00 PM	17	28	0	5	50	80	77
10:15 PM	21	14	0	1	36		
10:30 PM	16	17	1	1	35		
10:45 PM	26	18	4	2	50		
11:00 PM	16	24	0	3	43	74	84
11:15 PM	25	14	2	2	43		
11:30 PM	18	21	0	1	40		
11:45 PM	15	25	2	3	45		
12:00 AM	8	21	0	0	29	56	69
12:15 AM	17	13	2	1	33		
12:30 AM	16	19	0	1	36		
12:45 AM	15	16	2	1	34		
1:00 AM	14	10	1	1	26	70	57
1:15 AM	18	9	3	2	32		
1:30 AM	16	23	2	5	46		
1:45 AM	22	15	3	2	42		
2:00 PM	22	28	3	1	54	82	78
2:15 PM	31	23	4	3	61		
2:30 PM	13	18	0	1	32		
2:45 PM	16	9	3	1	29		
3:00 PM	8	11	0	2	21	39	68
3:15 PM	15	9	1	0	25		
3:30 PM	7	34	2	7	50		
3:45 PM	9	14	0	2	25		
4:00 PM	13	17	3	2	35	24	51
4:15 PM	5	20	1	3	29		
4:30 PM	5	7	0	0	12		
4:45 PM	1	7	0	1	9		
5:00 PM	5	22	0	3	30	16	44
5:15 PM	2	12	0	4	18		
5:30 PM	1	5	0	0	6		
5:45 PM	8	5	1	0	14		
6:00 PM	8	11	1	0	20	94	29
6:15 PM	39	6	5	0	50		
6:30 PM	33	7	6	0	46		
6:45 PM	14	5	1	0	20		
7:00 PM	4	2	0	0	6	38	17
7:15 PM	22	6	4	0	32		
7:30 PM	6	6	1	2	15		
7:45 PM	6	3	1	1	11		
8:00 PM	10	74	1	20	105	19	94
8:15 PM	6	10	1	2	19		
8:30 PM	0	5	0	2	7		
8:45 PM	3	5	0	1	9		
9:00 PM	2	21	0	5	28	6	23
9:15 PM	0	0	0	0	0		
9:30 PM	1	1	0	0	2		
9:45 PM	3	1	1	0	5		
10:00 PM	4	0	0	0	4	6	14
10:15 PM	1	3	0	1	5		
10:30 PM	1	10	0	3	14		
10:45 PM	0	1	0	0	1		
11:00 PM	0	0	0	0	0	0	1
11:15 PM	0	0	0	0	0		
11:30 PM	0	0	0	0	0		
11:45 PM	0	1	0	0	1		
<b>Grand Totals</b>	<b>840</b>	<b>789</b>	<b>83</b>	<b>105</b>	<b>1817</b>		

### Pedestrian Study

Location: Entrance to 510 Building West/N/O N Prospect Ave

City: Redondo Beach

Date: 10/22/2019

Day: Tuesday

TIME	Peds				TOTAL	INS	OUTS
	Individual Peds		Groups				
	In	Out	In	Out			
12:00 AM	0	0	0	0	0	0	0
12:15 AM	0	0	0	0	0		
12:30 AM	0	0	0	0	0		
12:45 AM	0	0	0	0	0		
1:00 AM	0	0	0	0	0	0	0
1:15 AM	0	0	0	0	0		
1:30 AM	0	0	0	0	0		
1:45 AM	0	0	0	0	0		
2:00 AM	0	0	0	0	0	0	0
2:15 AM	0	0	0	0	0		
2:30 AM	0	0	0	0	0		
2:45 AM	0	0	0	0	0		
3:00 AM	1	0	0	0	1	1	2
3:15 AM	0	2	0	0	2		
3:30 AM	0	0	0	0	0		
3:45 AM	0	0	0	0	0		
4:00 AM	0	0	0	0	0	0	0
4:15 AM	0	0	0	0	0		
4:30 AM	0	0	0	0	0		
4:45 AM	0	0	0	0	0		
5:00 AM	0	0	0	0	0	0	0
5:15 AM	0	0	0	0	0		
5:30 AM	0	0	0	0	0		
5:45 AM	0	0	0	0	0		
6:00 AM	0	0	0	0	0	12	1
6:15 AM	4	0	1	0	5		
6:30 AM	2	1	0	0	3		
6:45 AM	6	0	0	0	6		
7:00 AM	3	0	1	0	4	35	11
7:15 AM	7	4	1	1	13		
7:30 AM	9	0	2	0	11		
7:45 AM	16	7	1	3	27		
8:00 AM	6	6	0	0	12	53	40
8:15 AM	12	12	1	3	28		
8:30 AM	12	7	0	1	20		
8:45 AM	23	15	4	3	45		
9:00 AM	17	13	2	2	34	56	43
9:15 AM	13	11	2	2	28		
9:30 AM	8	7	1	0	16		
9:45 AM	18	12	2	0	32		
10:00 PM	16	14	1	1	32	52	47
10:15 PM	11	13	1	1	26		
10:30 PM	18	8	4	1	31		
10:45 PM	7	12	0	1	20		
11:00 PM	8	19	0	3	30	33	51
11:15 PM	12	15	2	3	32		
11:30 PM	5	11	0	1	17		
11:45 PM	8	6	0	1	15		
12:00 AM	11	10	2	2	25	32	37
12:15 AM	6	19	0	4	29		
12:30 AM	10	6	2	1	19		
12:45 AM	5	2	0	0	7		
1:00 AM	15	6	5	1	27	47	38
1:15 AM	15	11	1	2	29		
1:30 AM	11	5	0	1	17		
1:45 AM	6	16	1	4	27		
2:00 PM	10	13	2	2	27	32	31
2:15 PM	8	6	1	2	17		
2:30 PM	4	9	0	1	14		
2:45 PM	10	3	2	0	15		
3:00 PM	7	11	1	1	20	26	35
3:15 PM	6	14	0	1	21		
3:30 PM	6	4	1	0	11		
3:45 PM	7	6	1	0	14		
4:00 PM	1	3	0	0	4	15	17
4:15 PM	6	6	0	0	12		
4:30 PM	7	7	2	1	17		
4:45 PM	1	1	0	0	2		
5:00 PM	1	1	0	0	2	5	14
5:15 PM	3	5	1	1	10		
5:30 PM	0	3	0	1	4		
5:45 PM	1	5	0	0	6		
6:00 PM	2	3	0	0	5	5	7
6:15 PM	0	0	0	0	0		
6:30 PM	2	4	1	1	8		
6:45 PM	1	0	0	0	1		
7:00 PM	1	0	0	0	1	5	2
7:15 PM	0	2	0	0	2		
7:30 PM	0	0	0	0	0		
7:45 PM	4	0	1	0	5		
8:00 PM	0	3	0	1	4	1	4
8:15 PM	0	0	0	0	0		
8:30 PM	1	1	0	0	2		
8:45 PM	0	0	0	0	0		
9:00 PM	0	0	0	0	0	0	0
9:15 PM	0	0	0	0	0		
9:30 PM	0	0	0	0	0		
9:45 PM	0	0	0	0	0		
10:00 PM	0	0	0	0	0	0	0
10:15 PM	0	0	0	0	0		
10:30 PM	0	0	0	0	0		
10:45 PM	0	0	0	0	0		
11:00 PM	0	1	0	0	1	1	3
11:15 PM	0	0	0	0	0		
11:30 PM	1	2	0	0	3		
11:45 PM	0	0	0	0	0		
<b>Grand Totals</b>	<b>411</b>	<b>383</b>	<b>50</b>	<b>54</b>	<b>898</b>		



### Pedestrian Study

Location: Entrance to 510 Building East N/O N Prospect Ave

City: Redondo Beach

Date: 10/22/2019

Day: Tuesday

TIME	Peds				TOTAL	INS	OUTS
	Individual Peds		Groups				
	In	Out	In	Out			
12:00 AM	0	0	0	0	0	0	0
12:15 AM	0	0	0	0	0		
12:30 AM	0	0	0	0	0		
12:45 AM	0	0	0	0	0		
1:00 AM	0	0	0	0	0	0	0
1:15 AM	0	0	0	0	0		
1:30 AM	0	0	0	0	0		
1:45 AM	0	0	0	0	0		
2:00 AM	0	0	0	0	0	0	0
2:15 AM	0	0	0	0	0		
2:30 AM	0	0	0	0	0		
2:45 AM	0	0	0	0	0		
3:00 AM	0	0	0	0	0	0	0
3:15 AM	0	0	0	0	0		
3:30 AM	0	0	0	0	0		
3:45 AM	0	0	0	0	0		
4:00 AM	0	0	0	0	0	1	0
4:15 AM	0	0	0	0	0		
4:30 AM	0	0	0	0	0		
4:45 AM	1	0	0	0	1		
5:00 AM	1	0	0	0	1	4	0
5:15 AM	1	0	0	0	1		
5:30 AM	1	0	0	0	1		
5:45 AM	1	0	0	0	1		
6:00 AM	2	0	0	0	2	10	0
6:15 AM	3	0	0	0	3		
6:30 AM	0	0	0	0	0		
6:45 AM	5	0	0	0	5		
7:00 AM	5	0	0	0	5	56	7
7:15 AM	8	1	1	0	10		
7:30 AM	22	3	2	0	27		
7:45 AM	21	3	2	0	26		
8:00 AM	20	7	3	0	30	71	32
8:15 AM	17	7	4	1	29		
8:30 AM	22	7	3	1	33		
8:45 AM	12	11	0	4	27		
9:00 AM	15	10	1	3	29	61	50
9:15 AM	10	17	1	4	32		
9:30 AM	19	10	3	2	34		
9:45 AM	17	13	4	2	36		
10:00 PM	16	14	2	3	35	60	46
10:15 PM	15	15	2	4	36		
10:30 PM	7	9	0	0	16		
10:45 PM	22	8	6	0	36		
11:00 PM	10	18	0	4	32	46	64
11:15 PM	10	21	2	6	39		
11:30 PM	16	10	4	2	32		
11:45 PM	10	15	1	4	30		
12:00 AM	7	12	3	3	25	38	52
12:15 AM	8	14	0	2	24		
12:30 AM	12	18	2	1	33		
12:45 AM	11	8	3	0	22		
1:00 AM	20	13	3	1	37	68	44
1:15 AM	17	11	0	2	30		
1:30 AM	15	9	1	1	26		
1:45 AM	16	11	6	2	35		
2:00 PM	10	12	0	2	24	46	49
2:15 PM	8	10	0	2	20		
2:30 PM	13	13	3	2	31		
2:45 PM	15	14	1	3	33		
3:00 PM	11	7	1	2	21	33	56
3:15 PM	8	10	0	2	20		
3:30 PM	10	23	2	4	39		
3:45 PM	4	16	0	2	22		
4:00 PM	7	9	1	1	18	26	56
4:15 PM	6	15	0	2	23		
4:30 PM	7	24	1	4	36		
4:45 PM	6	8	2	0	16		
5:00 PM	0	11	0	2	13	8	34
5:15 PM	2	9	0	2	13		
5:30 PM	5	12	1	1	19		
5:45 PM	1	2	0	1	4		
6:00 PM	2	4	1	1	8	5	17
6:15 PM	2	4	0	0	6		
6:30 PM	0	8	0	2	10		
6:45 PM	1	1	0	0	2		
7:00 PM	2	1	0	0	3	2	2
7:15 PM	0	1	0	0	1		
7:30 PM	0	0	0	0	0		
7:45 PM	0	0	0	0	0		
8:00 PM	0	5	0	1	6	0	6
8:15 PM	0	0	0	0	0		
8:30 PM	0	0	0	0	0		
8:45 PM	0	1	0	0	1		
9:00 PM	0	1	0	0	1	0	1
9:15 PM	0	0	0	0	0		
9:30 PM	0	0	0	0	0		
9:45 PM	0	0	0	0	0		
10:00 PM	0	0	0	0	0	1	2
10:15 PM	1	1	0	0	2		
10:30 PM	0	1	0	0	1		
10:45 PM	0	0	0	0	0		
11:00 PM	0	2	0	0	2	0	2
11:15 PM	0	0	0	0	0		
11:30 PM	0	0	0	0	0		
11:45 PM	0	0	0	0	0		
<b>Grand Totals</b>	<b>536</b>	<b>520</b>	<b>72</b>	<b>88</b>	<b>1216</b>		

**Appendix C – Ballard\*King &  
Associates Aquatics Center Preliminary  
Market Feasibility Evaluation**



**BALLARD\* KING**  
& ASSOCIATES LTD  
Recreation Facility Planning and Operation Consultants

Beach Cities Health District (BCHD) hired Ballard\*King & Associates (B\*K), a recreation facility planning firm based out of Denver, CO, to be their aquatic consultant. As part of the overall scope of services, B\*K is providing BCHD with the market for aquatic services in the area, recommendations for future aquatic facilities, and an operational plan for the facility. This document is meant to further describe the market for aquatic services (swimming), in BCHD.

**Primary Service Area.** The service area for the potential BCHD aquatic facility is the communities of Hermosa Beach, Manhattan Beach and Redondo Beach. B\*K defines a primary service area as the distance that individuals or families are willing to travel on at least a weekly basis to use facilities or participate in programs. The identification of the primary service area is a key component of determining the market and subsequent market penetration. By defining the market as previously stated it does not preclude individuals from outside that service area, ex. Torrance, from using the facility. It does mean that the market numbers and operational projections will be specific to the Primary Service Area.

Using demographic information gathered from Environmental Research Systems Institute (ESRI), the 2020 population estimate in the primary service area is 560,015 with a median age of 40.4 and a median household income of \$94,949. These data points become key indicators when developing participation numbers and market availability.

**Participation Statistics.** B\*K uses information gathered by the National Sporting Goods Association (NSGA)<sup>1</sup> to help determine the market for recreation activities, like swimming. The NSGA conducts an annual survey of how Americans spend their leisure time. In particular they collect data by age range (7 and up), median household income, and region of the country. Using the age distribution of the primary service area, combined with median household income, region of the country, and national average, B\*K produces a participation percentage unique to the characteristics of the primary service area.

For the BCHD service area this equates to an average of 16.6% that participate in swimming. The NSGA does not further define swimming, nor do they define if this is pool use, ocean, lake, etc. B\*K takes 16.6% and applies it to the population of the primary service area that is age 7 and up, which comes to 86,145. This means that within the primary service area 86,145 individuals, age 7 and up, participate in swimming.

B\*K can further extrapolate the number to determine the number of facility visits the 86,145 individuals account for. The NSGA defines swimmers as frequent (more than 110+ visits per

---

<sup>1</sup> National Sporting Goods Association Sports Participation in the United States 2020 Edition.



year and 8.5% of swimmers), occasional (25-109 visits per year and 41.7% of swimmers), and infrequent (6-24 visits per year and 49.8% of swimmers). For calculation purposes B\*K uses the following calculation factors; frequent (112 visits), occasional (67 visits), and infrequent (15 visits). There is a strong possibility that the 112 visits used for frequent could be higher, but B\*K provides a conservative estimate.

B\*K then completes the following, the total number of swimmers (86,145) are multiplied by the respective percentage; frequent (8.5% = 7,322), occasional (41.7% = 35,922), and infrequent (49.8% = 42,900). Those populations are then multiplied by the number of visits for each category; frequent (7,322 x 112), occasional (35,922 x 67), and infrequent (42,900 x 15). The result is that the population within the primary service area equates to 3,870,407 swimmer days over the course of a calendar year.

It is important to note that the swimmer days are not specific to a single facility, nor are they specific to facilities in the primary service area. These swimmer days could be absorbed at ANY aquatic facility, of ANY type, anywhere, or at the ocean.

**Penetration Rate:** If a private provider were to develop a recreation focused facility (aquatics) in an area, they would designate a location and draw a 5-mile radius around the location. This would identify their primary service area, and a goal would be to capture 5-10% of the population in that area. For an organization like BCHD that serves a much larger service area than a 5-mile radius the percentage of capture decreases. Based on previous work in the area, work across the country, and the presence of other providers, organizations like BCHD would hope to capture approximately 3% of the swimmer days. This would equate to approximately 116,112 swimmer visits over the course of a calendar year. These visits could come in the way of lap swimming, therapy, group exercise, open/recreational swim, etc. It is also important to note that a percentage would come from the residents of the BCHD campus.

While a 3% penetration may not seem overly ambitious the presence of other pool providers, the beach/ocean, and population concentration make it reasonable. The reality is that a private provider would hope to capture 5-10% of the participants within a 5-mile radius. The proposed BCHD is pulling from a much greater area based on their tax base, thus a larger population. While BCHD, could have a goal of capturing 5%, the reality is the size of facility required to capture that portion of market share would exceed the budget for the project and dedicated footprint for the facility.

# **Appendix D – Peak Period Turning Movements & Lane Geometries**

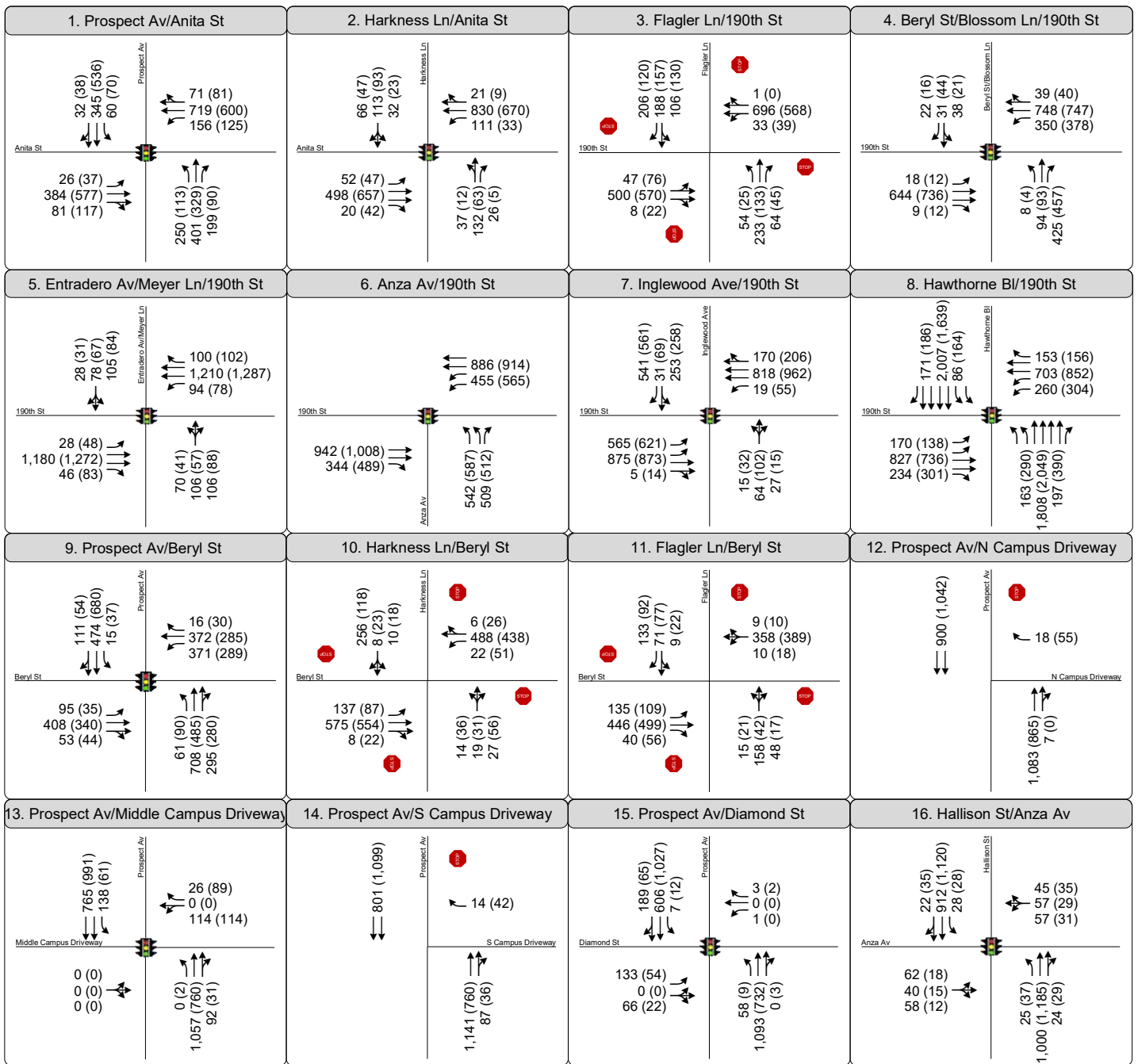

Peak Hour Traffic Volumes and Lane Configurations - Existing (2020) Conditions



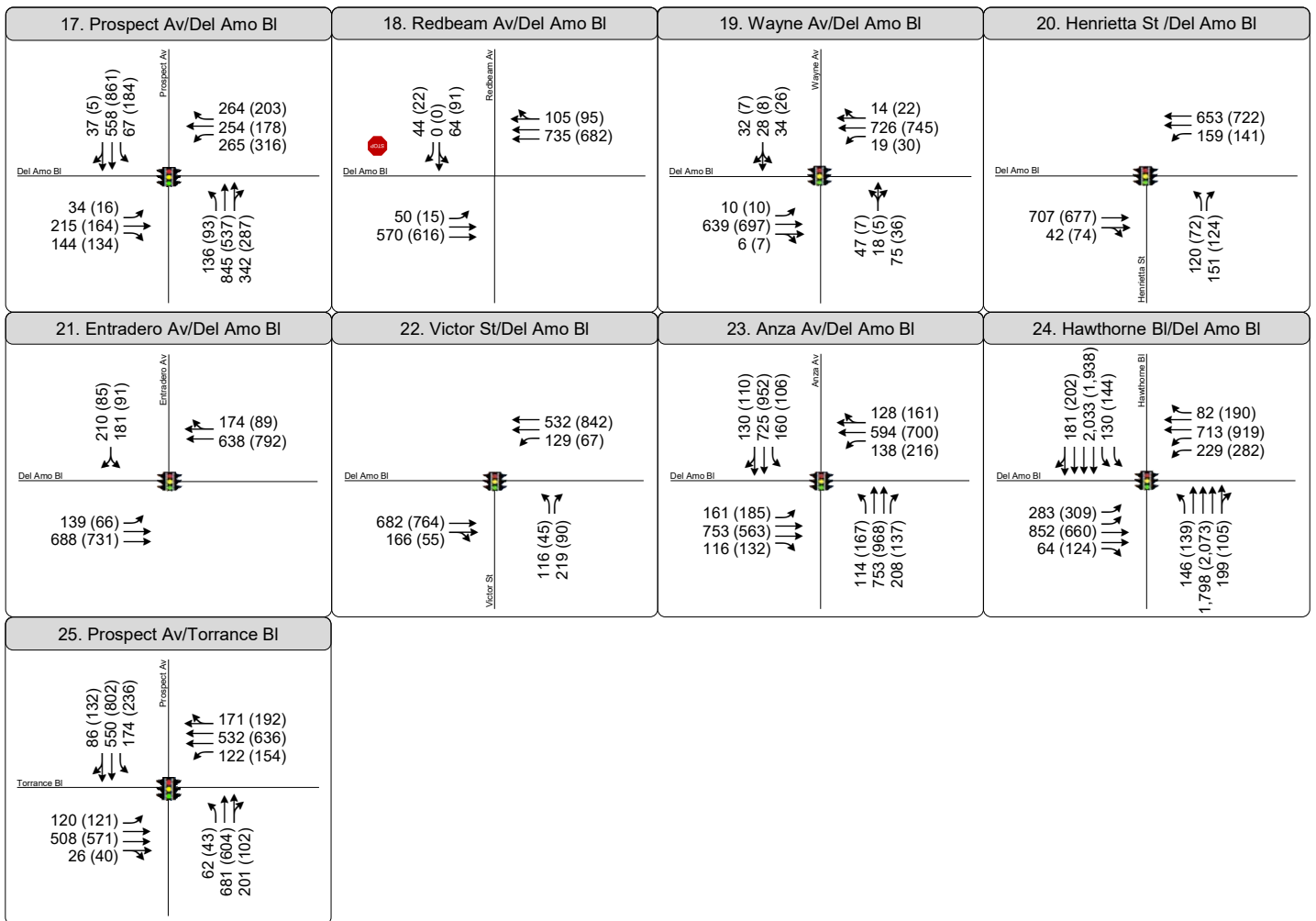

Peak Hour Traffic Volumes  
and Lane Configurations -  
Existing (2020) Conditions



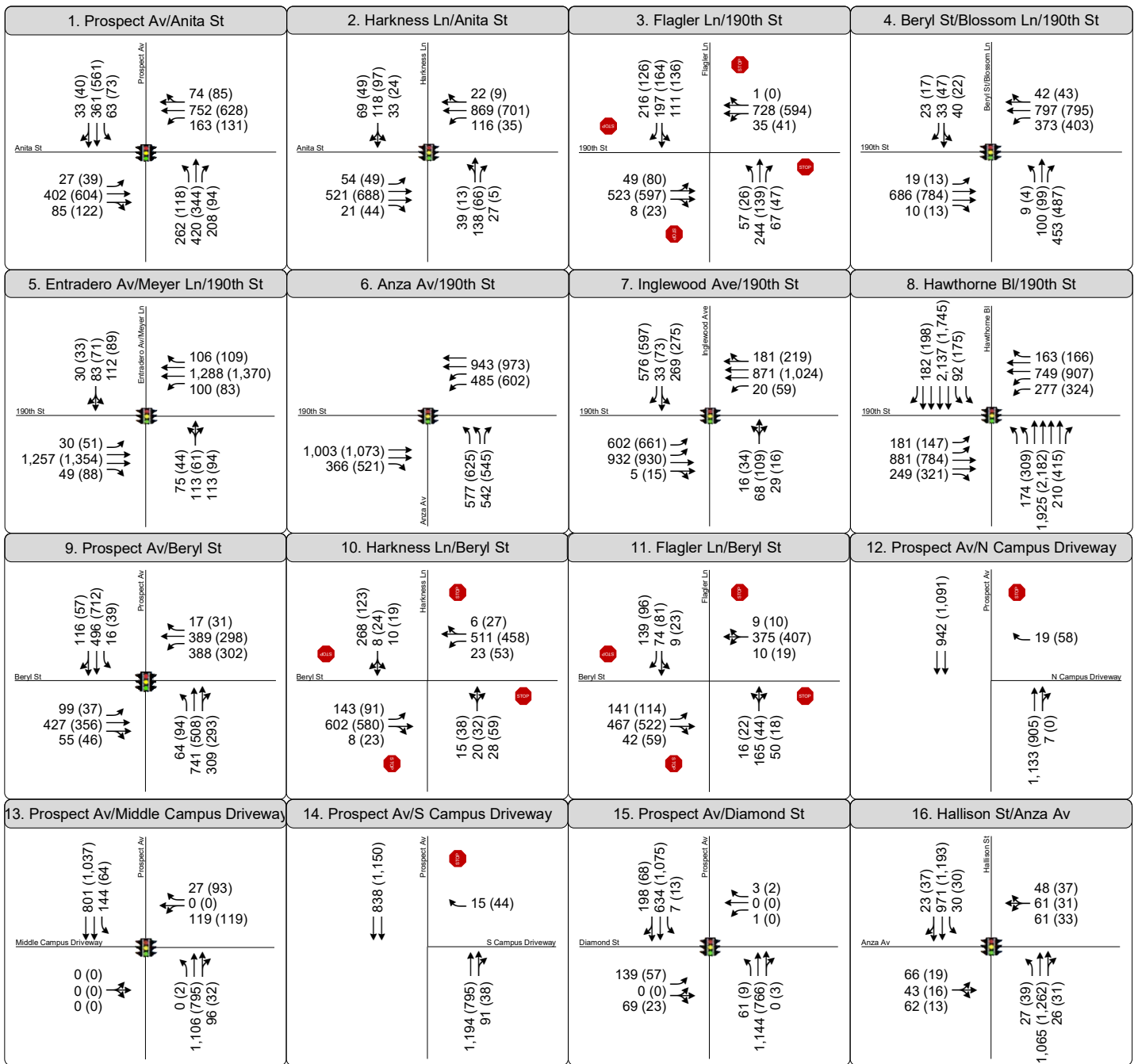

Peak Hour Traffic Volumes  
and Lane Configurations -  
Cumulative Baseline (2032) Conditions





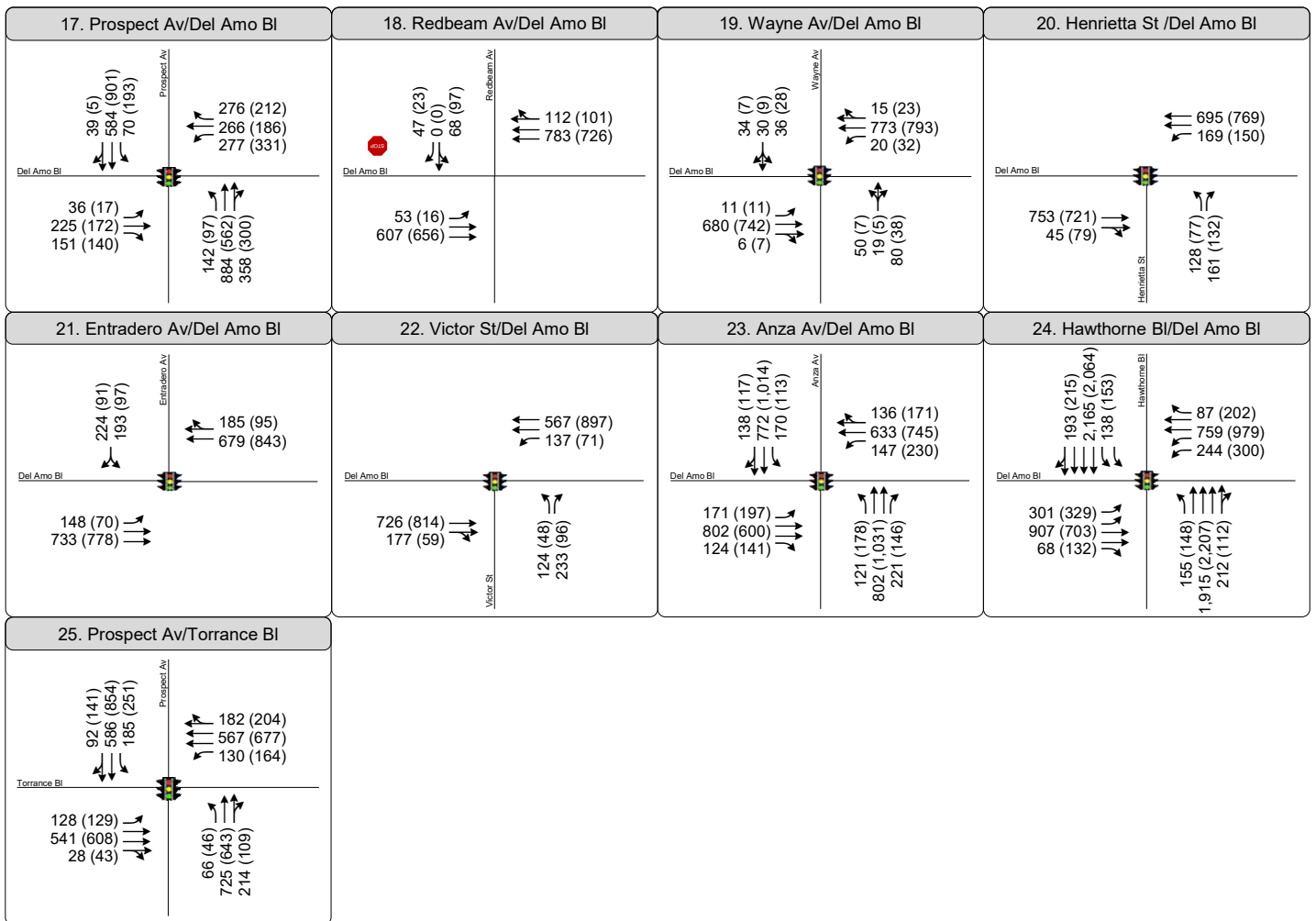

Peak Hour Traffic Volumes  
and Lane Configurations -  
Cumulative Baseline (2032) Conditions



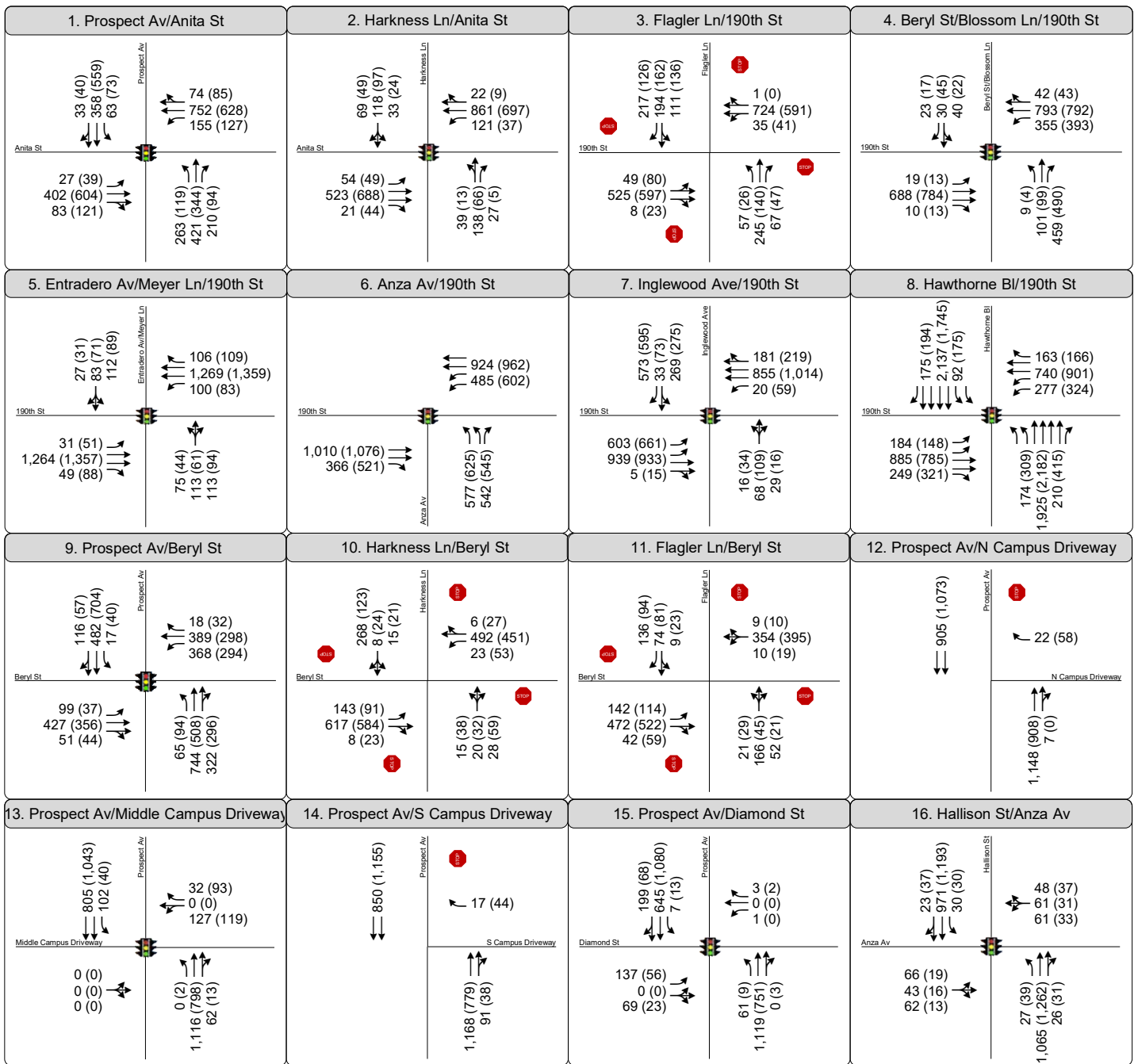

Peak Hour Traffic Volumes  
and Lane Configurations -  
Cumulative plus Project Conditions



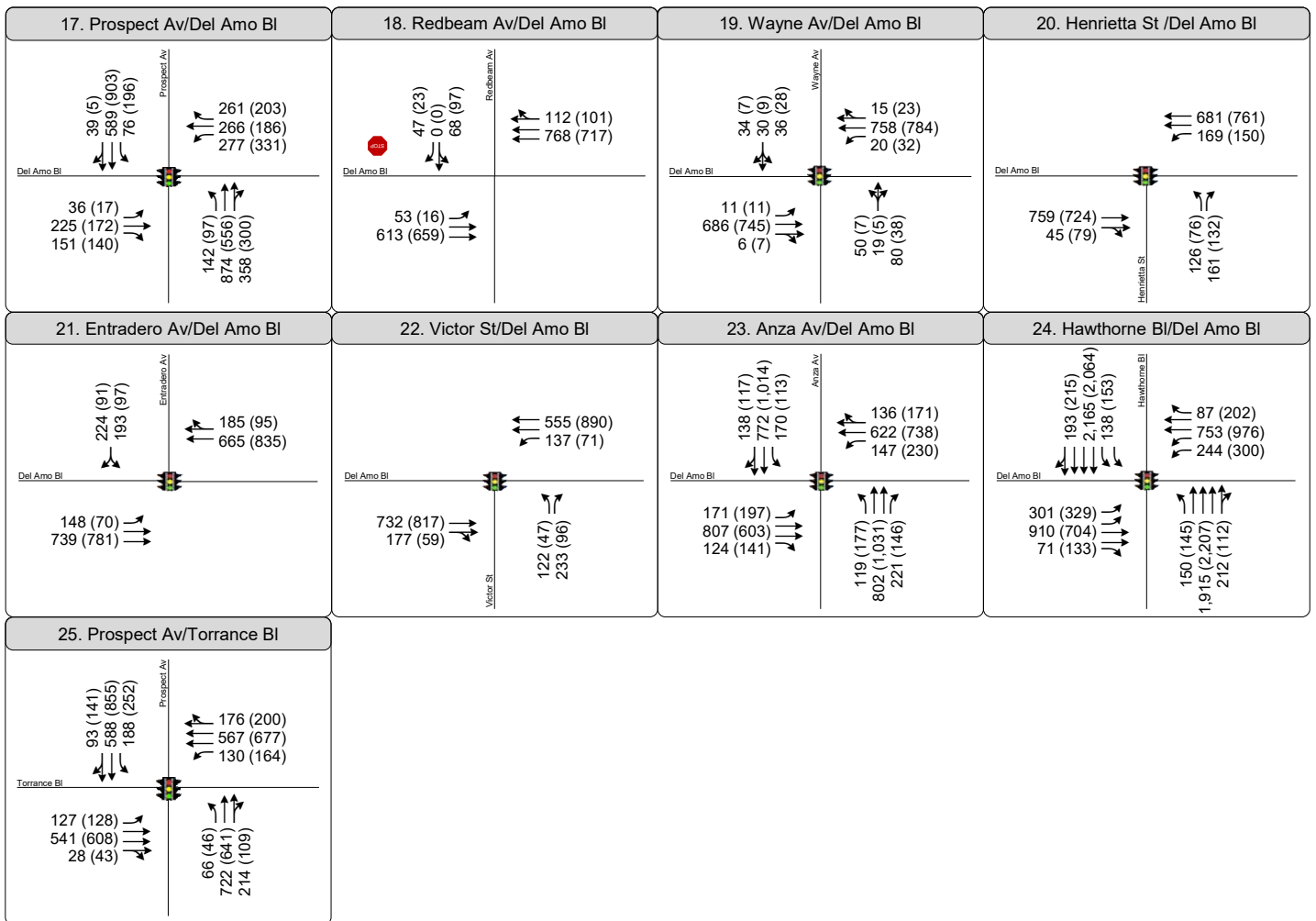

Peak Hour Traffic Volumes  
and Lane Configurations -  
Cumulative plus Project Conditions



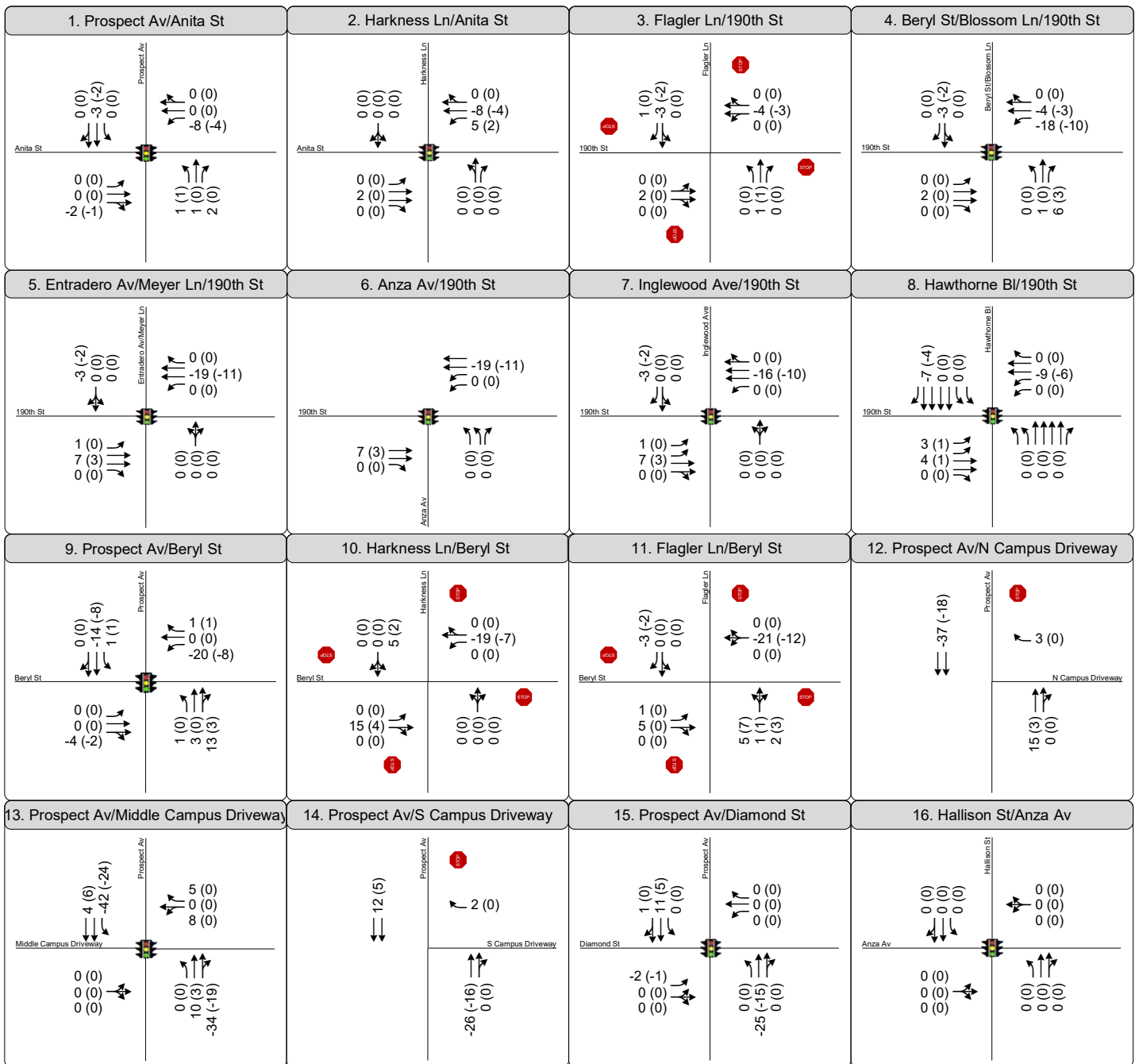

Peak Hour Traffic Volumes  
and Lane Configurations -  
Project Only Volumes



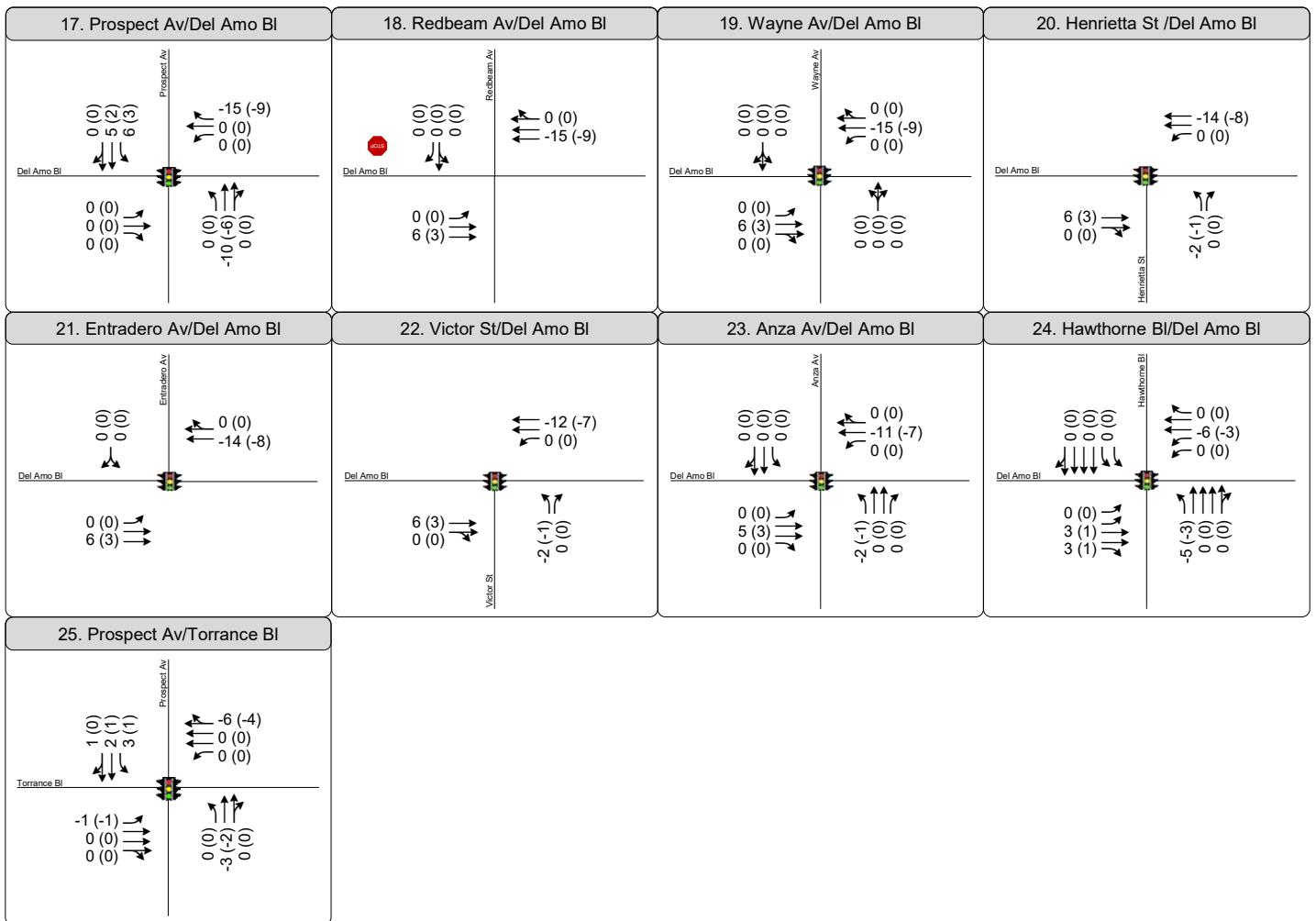

Peak Hour Traffic Volumes  
and Lane Configurations -  
Project Only Volumes



# Appendix E – Traffic Count Sheets

# Prospect Ave & Anita St

## Peak Hour Turning Movement Count

ID: 20-05014-001  
City: Redondo Beach

Day: Tuesday  
Date: 01/14/2020

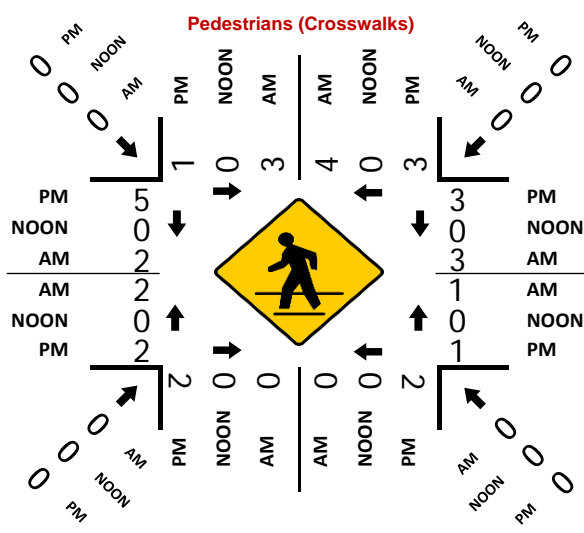
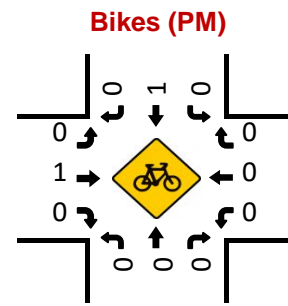
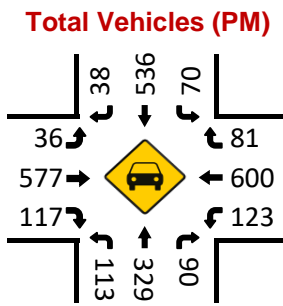
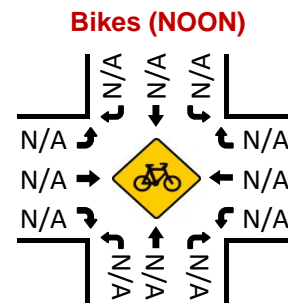
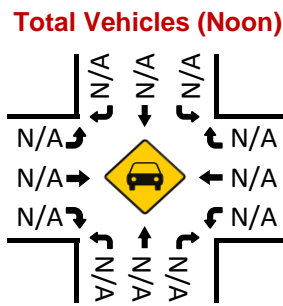
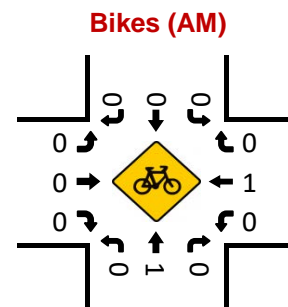
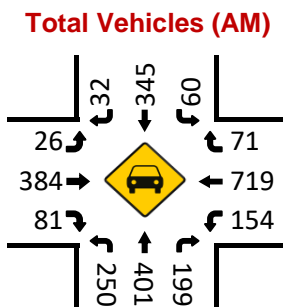
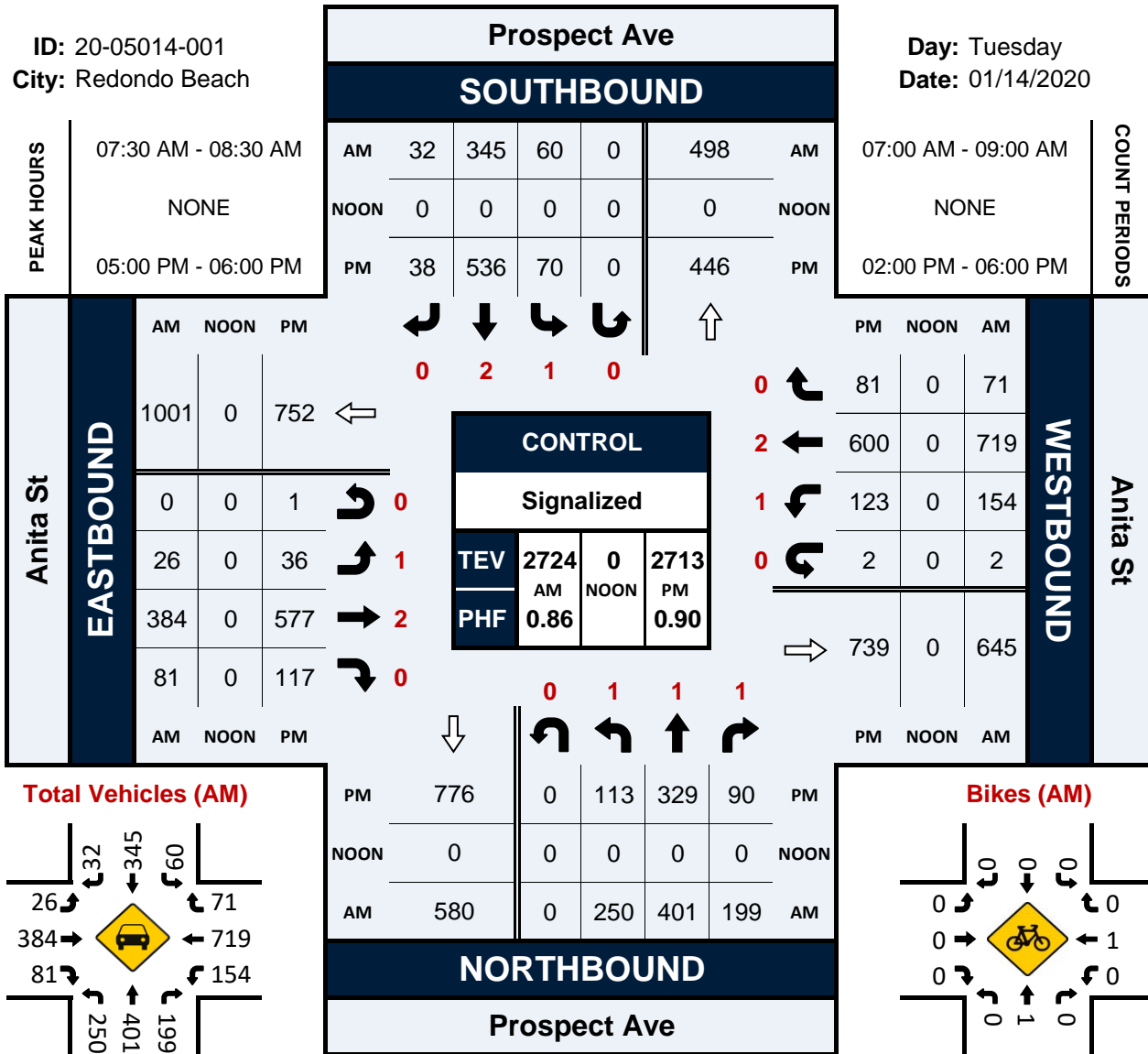

# Harkness Ln & Anita St

## Peak Hour Turning Movement Count

ID: 20-05014-002  
City: Redondo Beach

Day: Tuesday  
Date: 01/14/2020

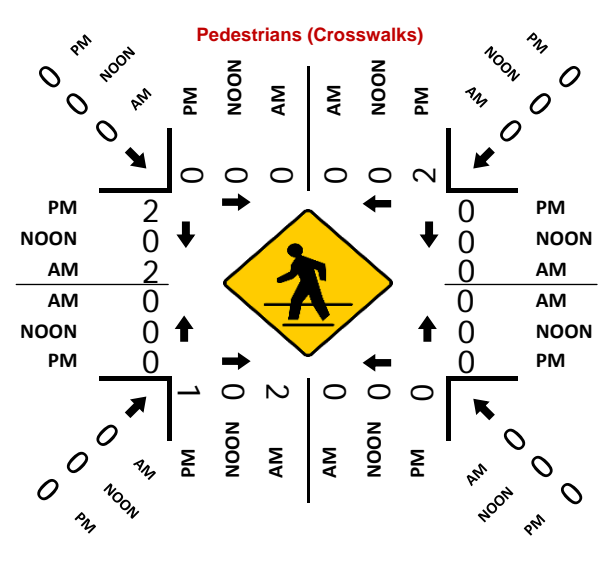
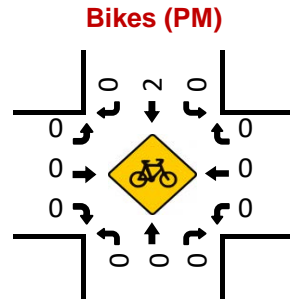
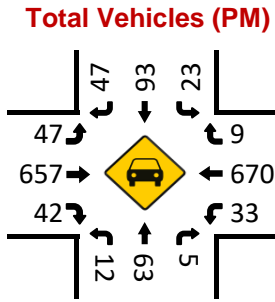
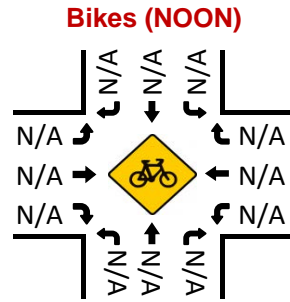
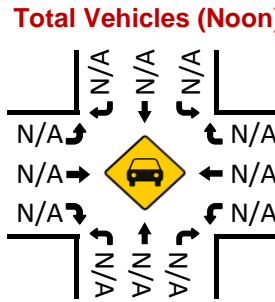
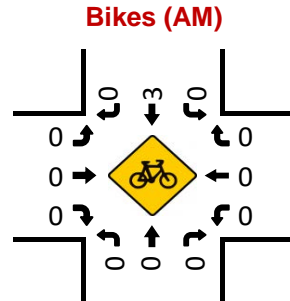
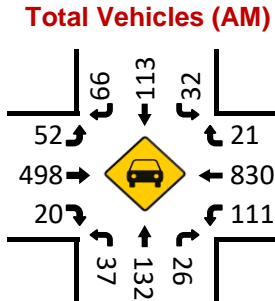
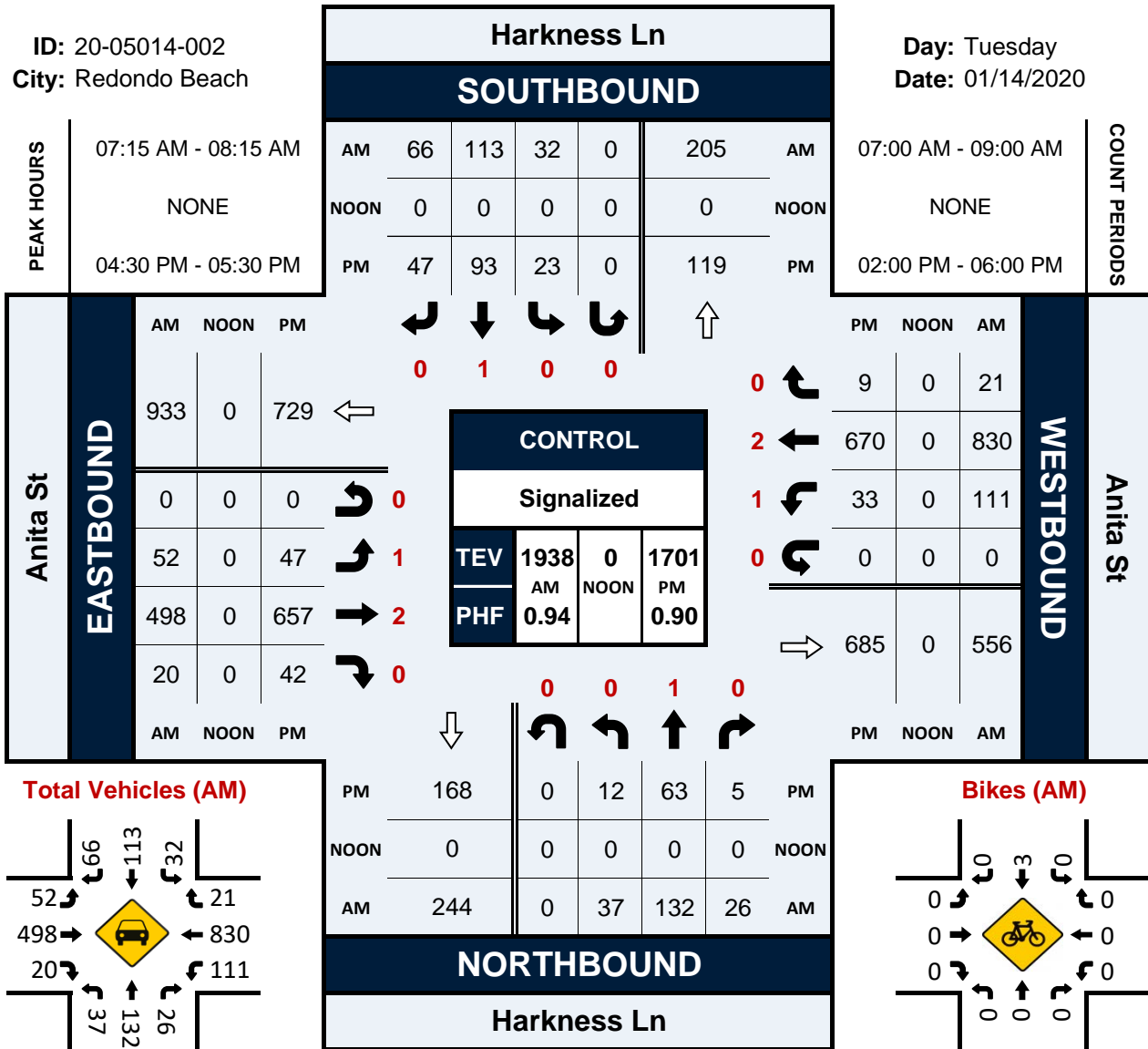



# Flagler Ln & 190th St/ Anita St

## Peak Hour Turning Movement Count

ID: 20-05014-003  
City: Redondo Beach

Day: Tuesday  
Date: 01/14/2020

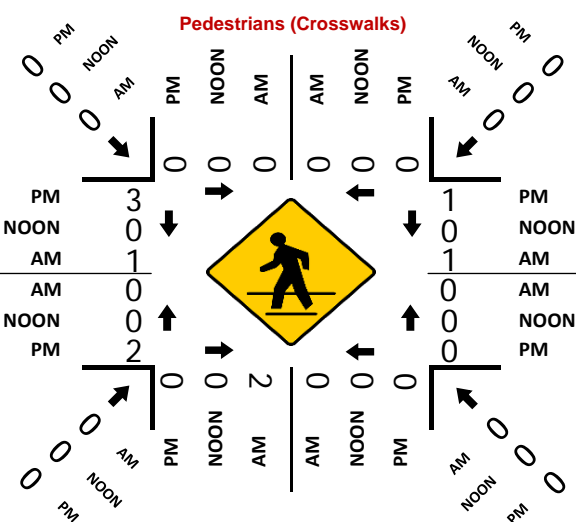
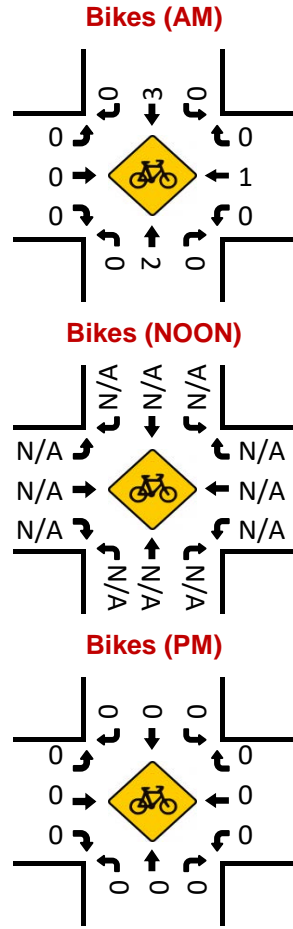
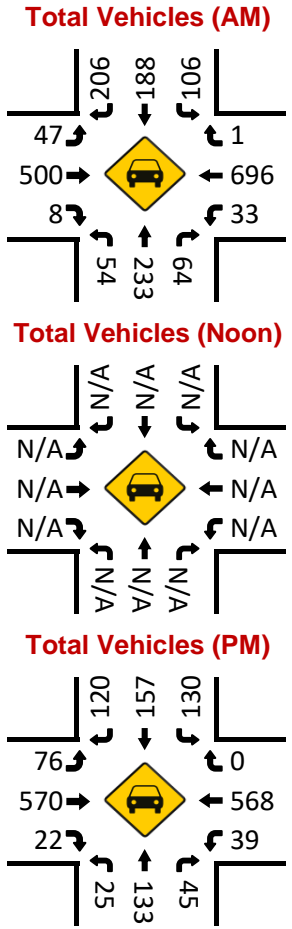
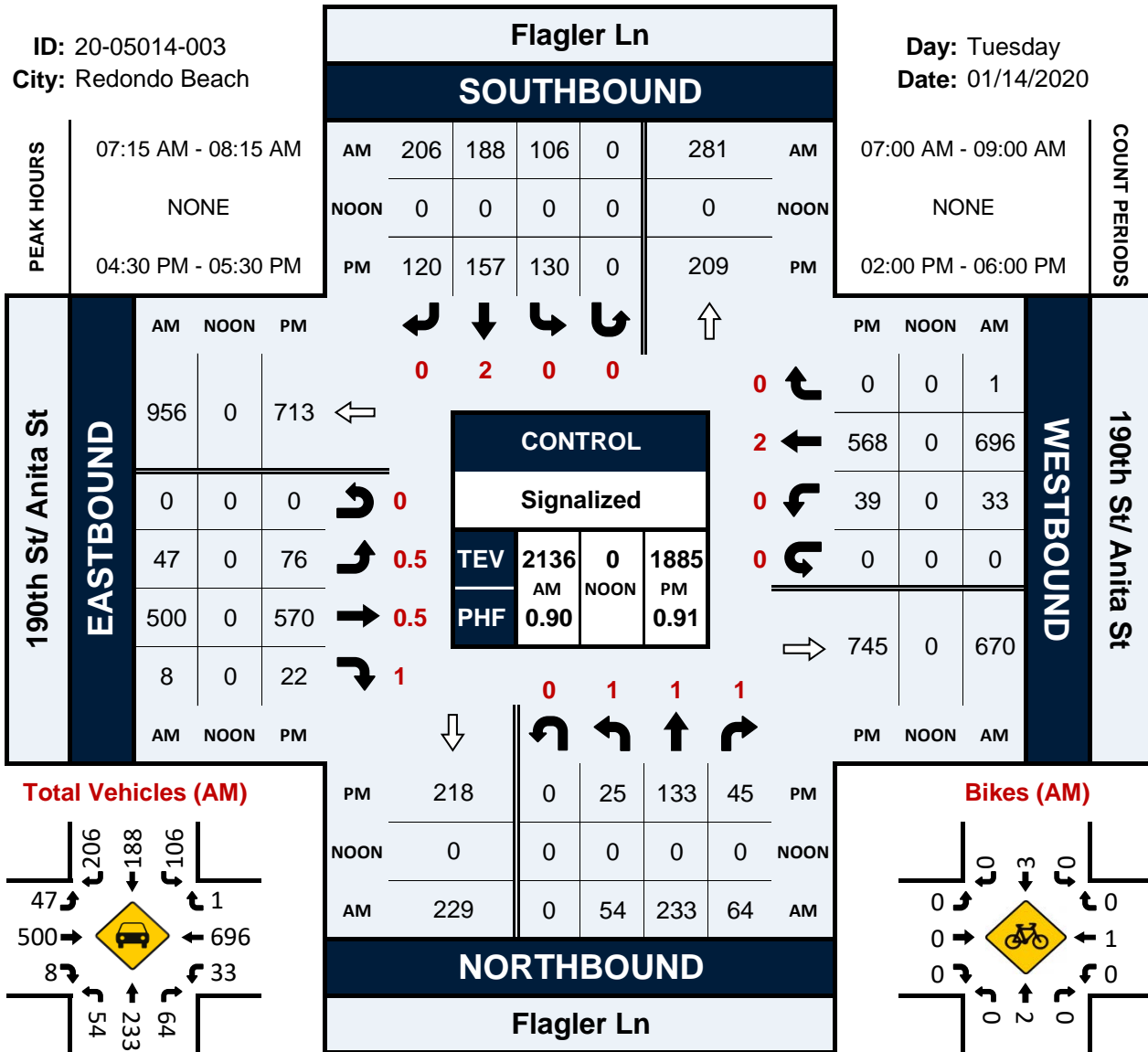

# Beryl St / Blossom Ln & 190th St

## Peak Hour Turning Movement Count

ID: 20-05014-004  
City: Redondo Beach

Day: Tuesday  
Date: 01/14/2020

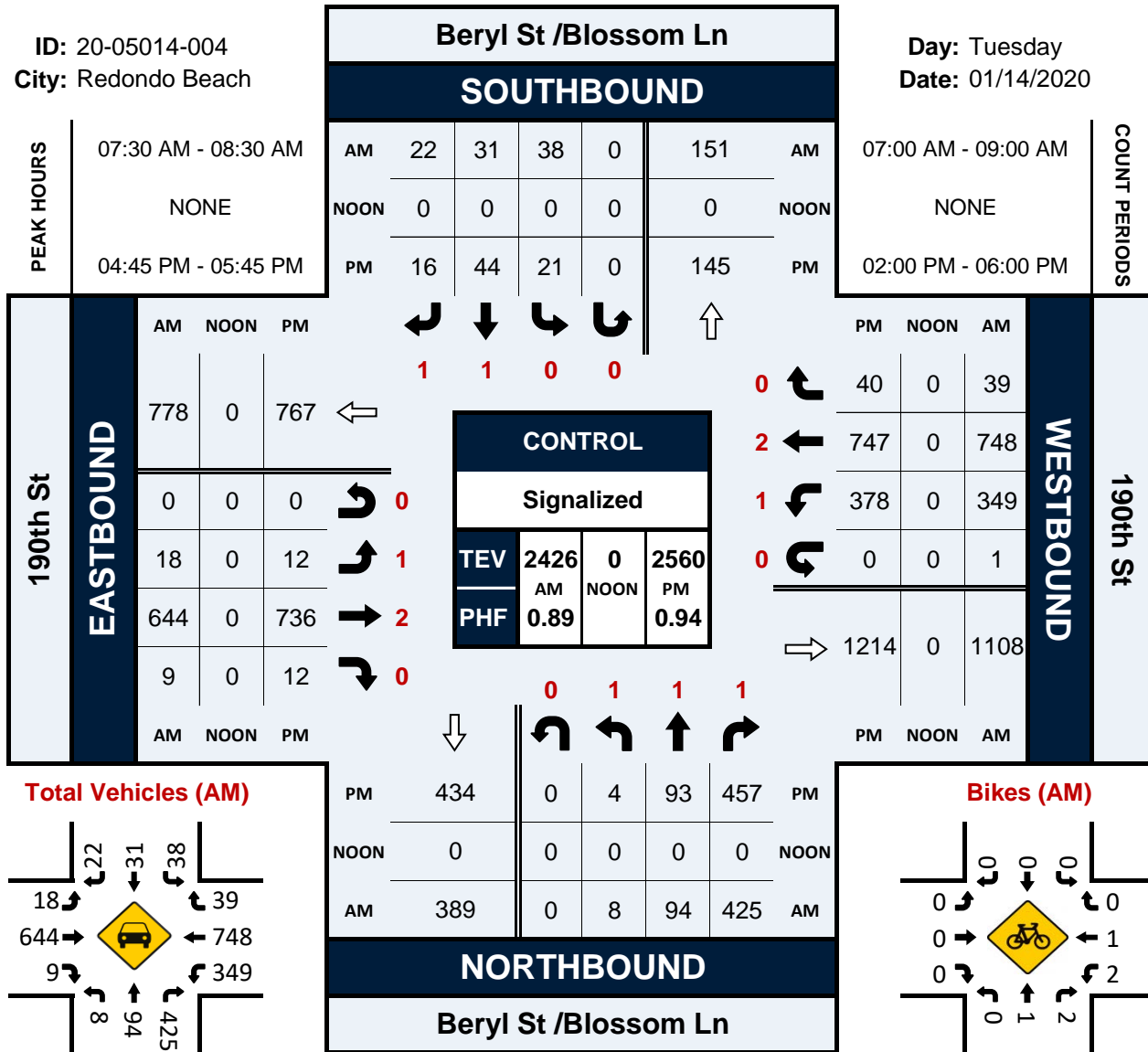

**Total Vehicles (AM)**

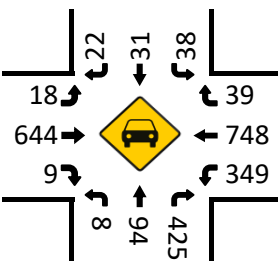

**Bikes (AM)**

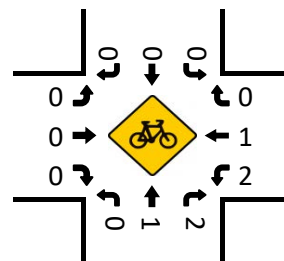

**Total Vehicles (Noon)**

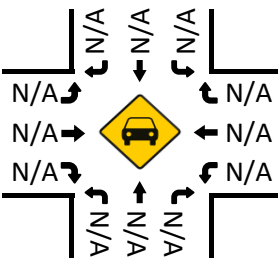

**Bikes (NOON)**

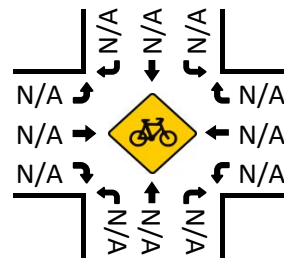

**Total Vehicles (PM)**

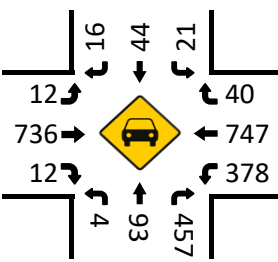

**Bikes (PM)**

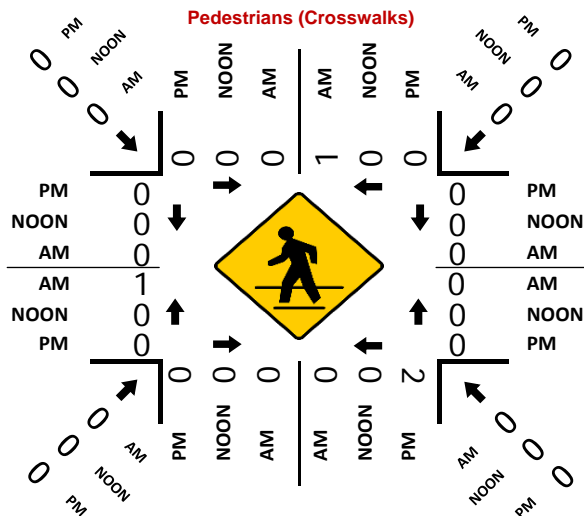
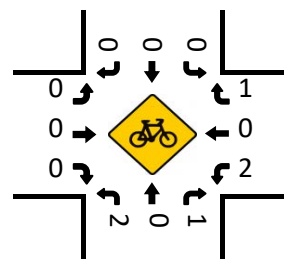

# Entradero Ave & 190th St

## Peak Hour Turning Movement Count

ID: 20-05014-005  
City: Torrance

Day: Tuesday  
Date: 01/14/2020

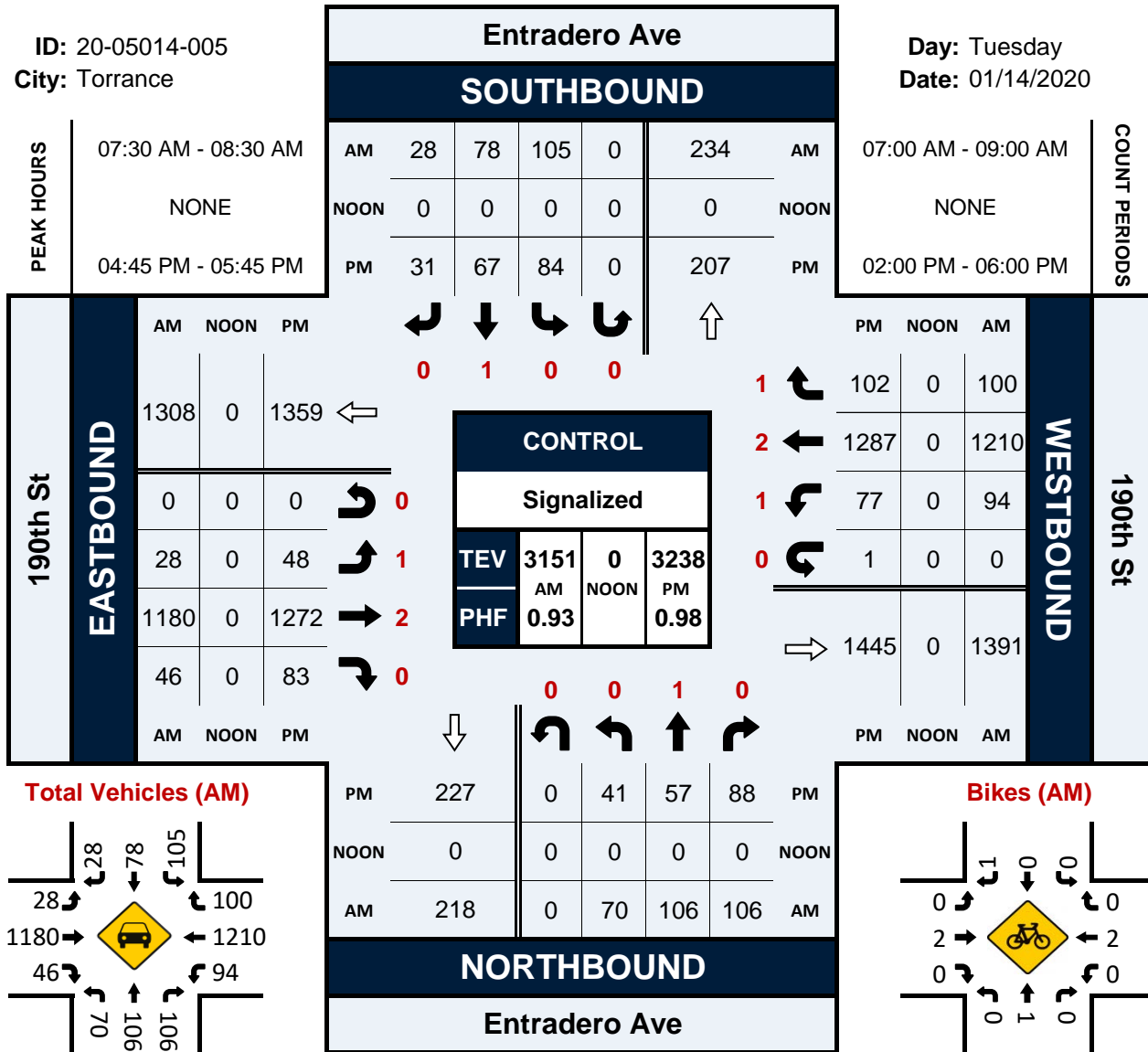

Total Vehicles (AM)

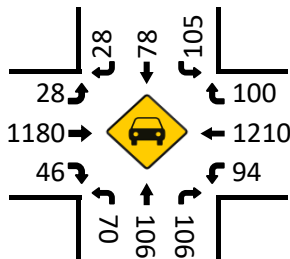

Bikes (AM)

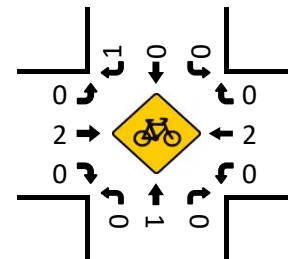

Total Vehicles (Noon)

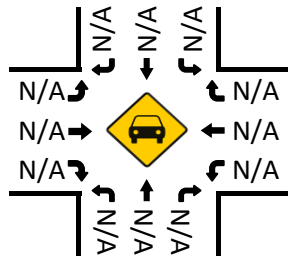

Bikes (NOON)

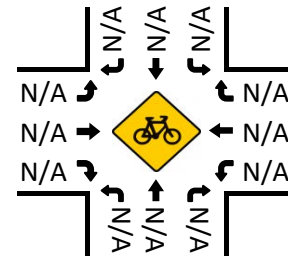

Total Vehicles (PM)

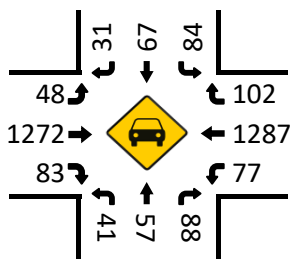

Bikes (PM)

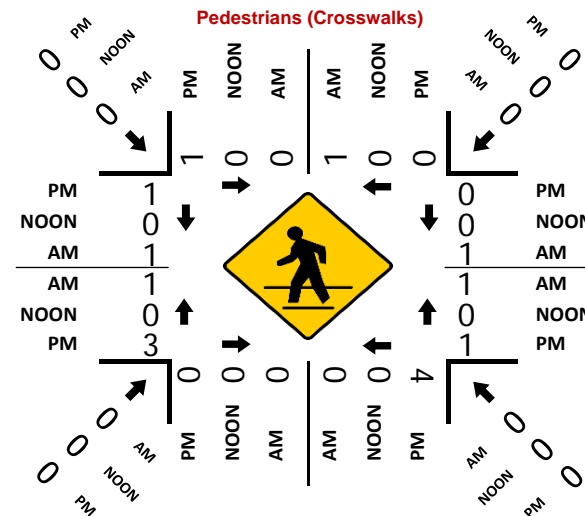
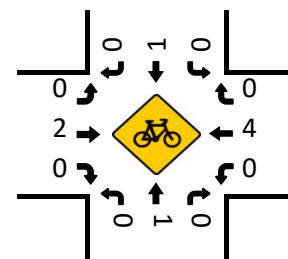

# Anza Ave & 190th St

## Peak Hour Turning Movement Count

ID: 20-05014-006  
City: Torrance

Day: Tuesday  
Date: 01/14/2020

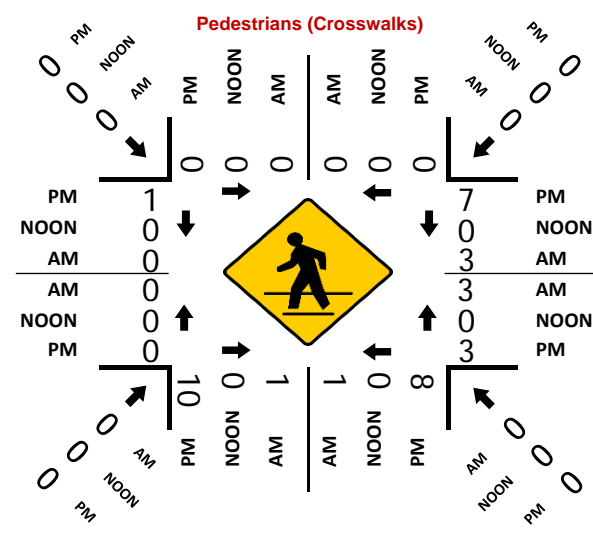
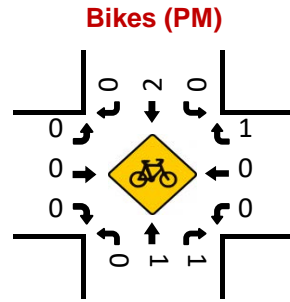
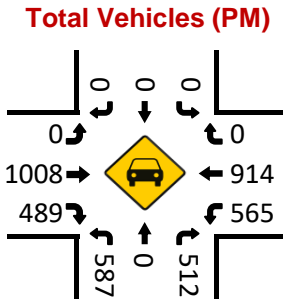
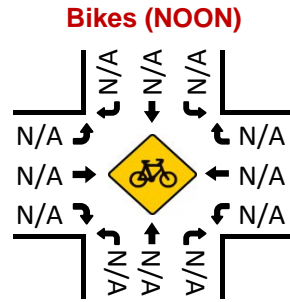
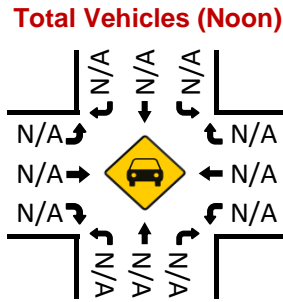
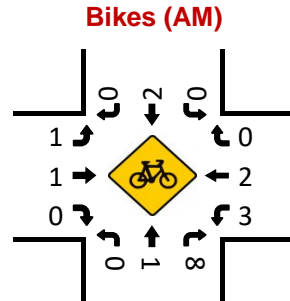
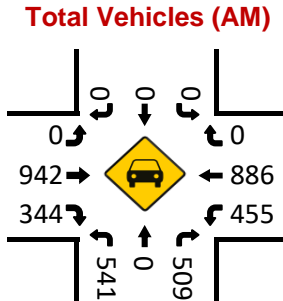
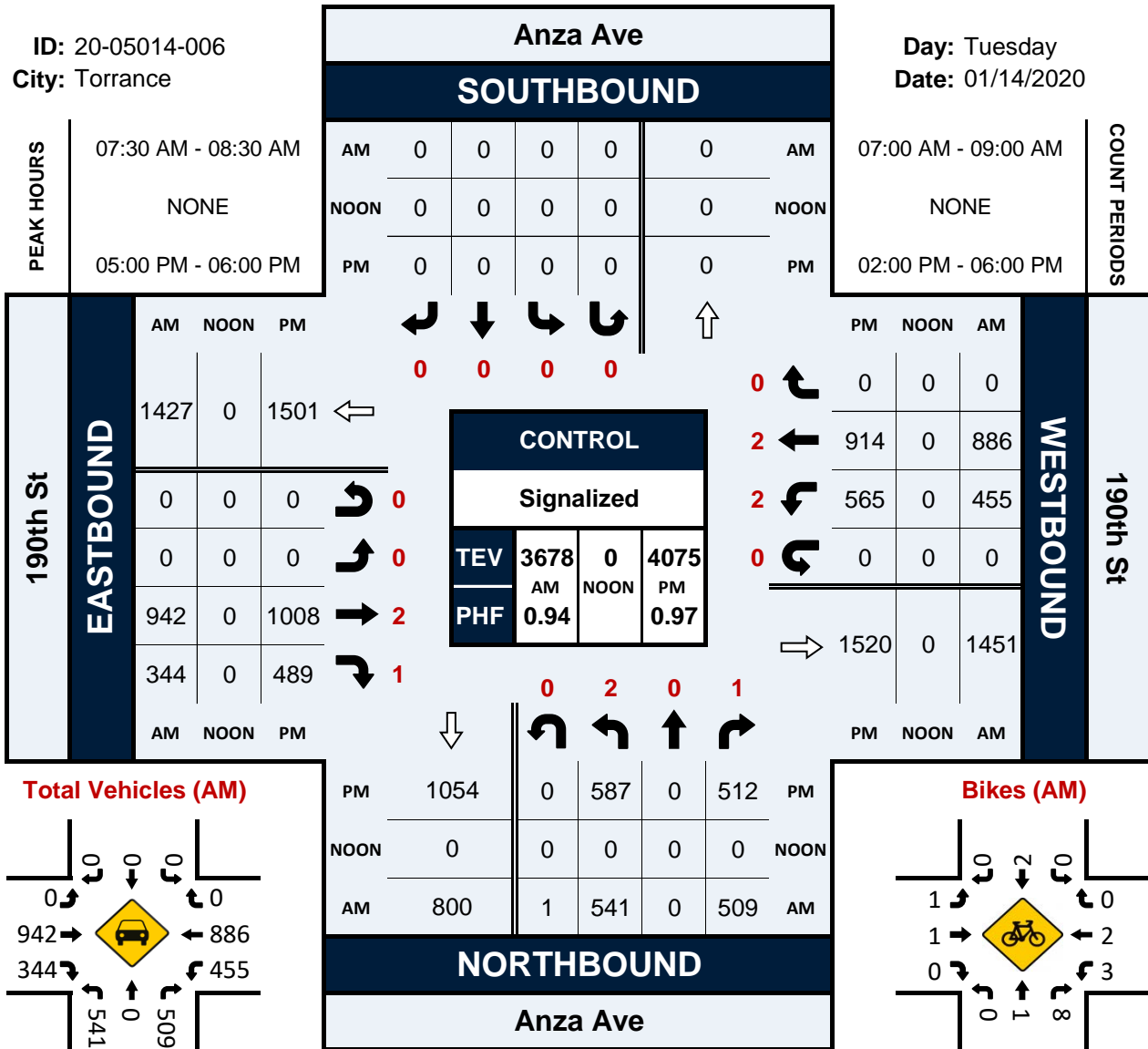

# Inglewood Ave & 190th St

## Peak Hour Turning Movement Count

ID: 20-05014-007  
City: Torrance

Day: Tuesday  
Date: 01/14/2020

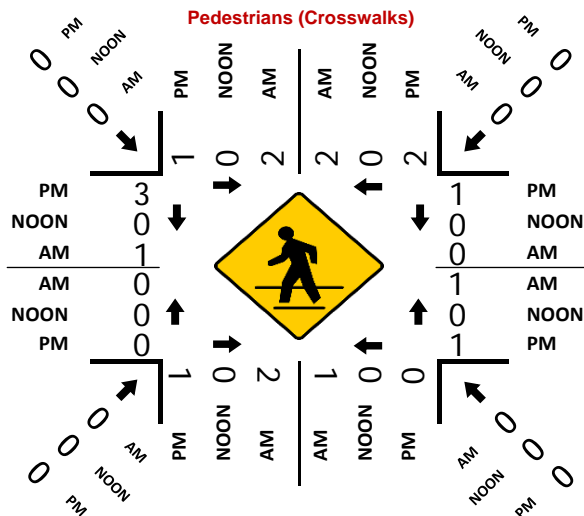
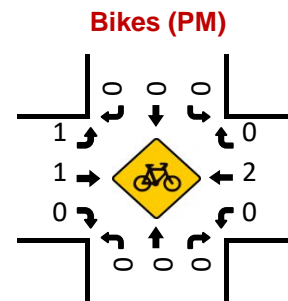
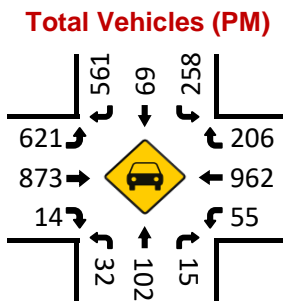
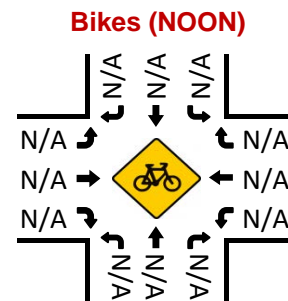
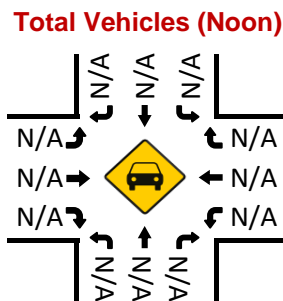
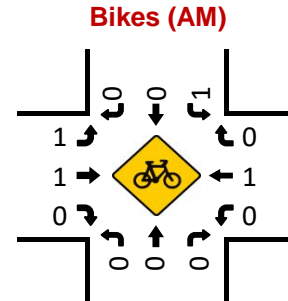
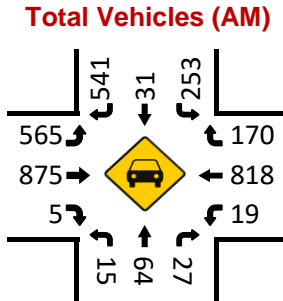
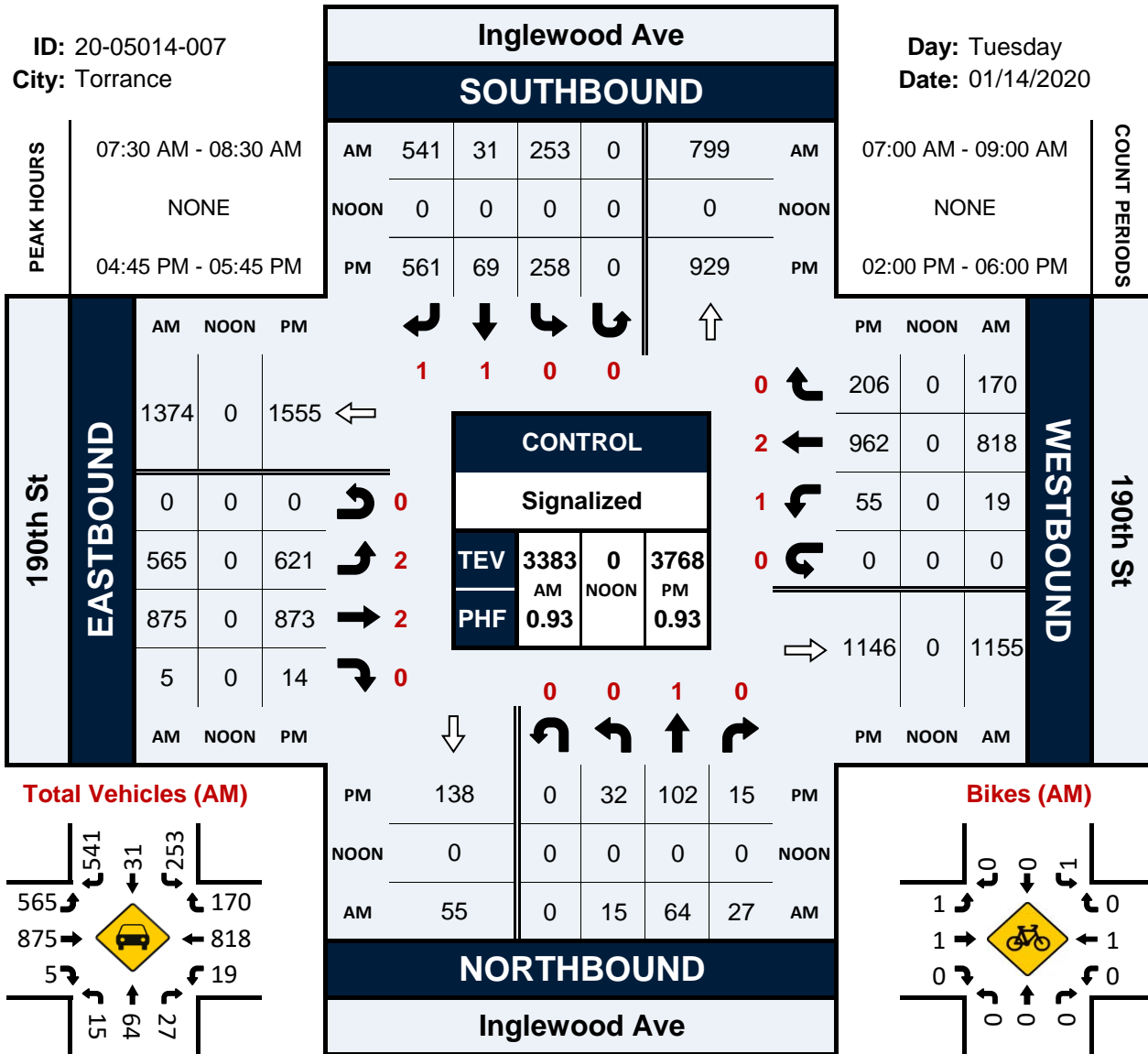

# Hawthorne Blvd & 190th St

## Peak Hour Turning Movement Count

ID: 20-05014-008  
City: Torrance

Day: Tuesday  
Date: 01/14/2020

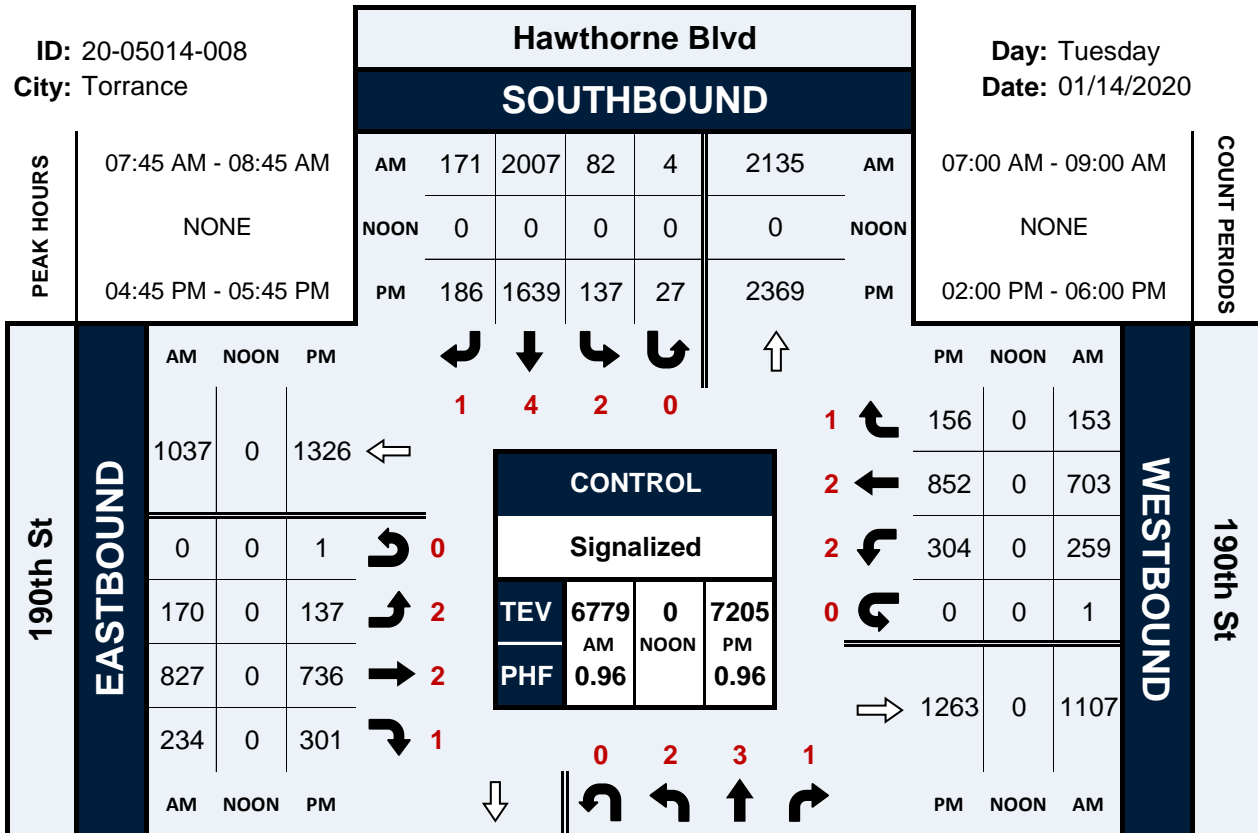

**Total Vehicles (AM)**

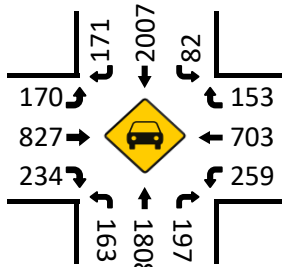

**Bikes (AM)**

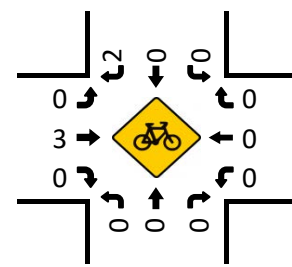

**Total Vehicles (Noon)**

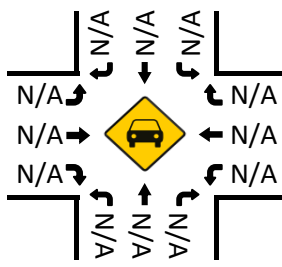

**Bikes (NOON)**

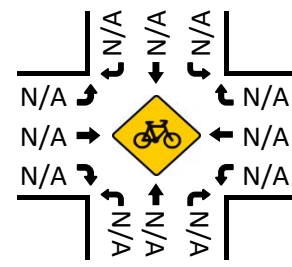

**Total Vehicles (PM)**

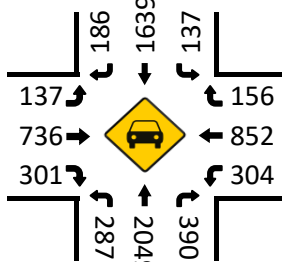

**Bikes (PM)**

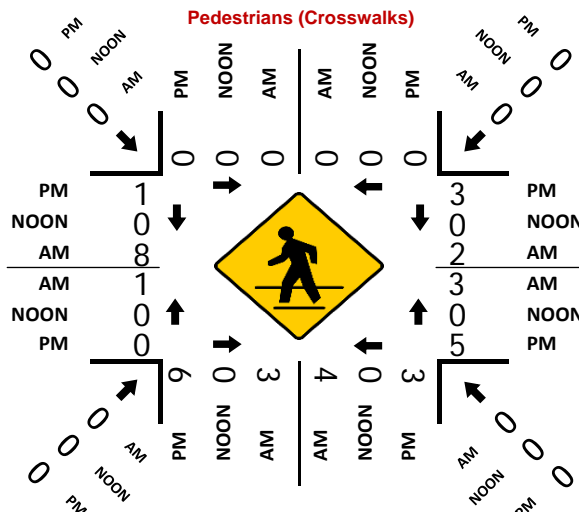
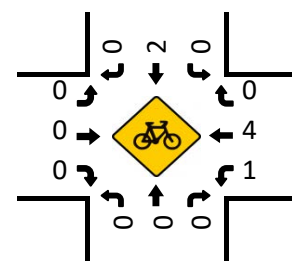

# Prospect Ave & Beryl St

## Peak Hour Turning Movement Count

ID: 20-05014-009  
City: Redondo Beach

Day: Tuesday  
Date: 01/14/2020

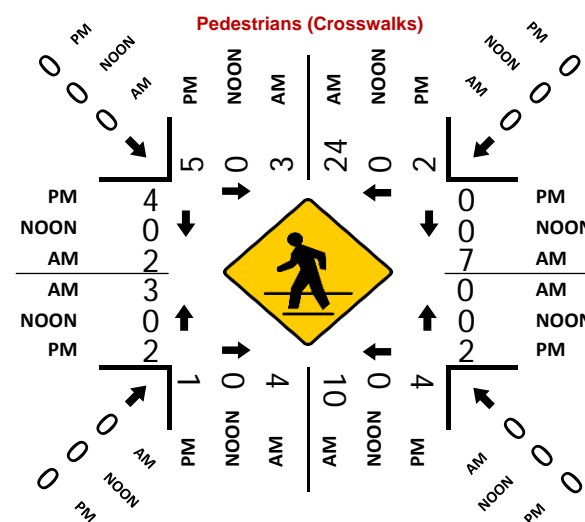
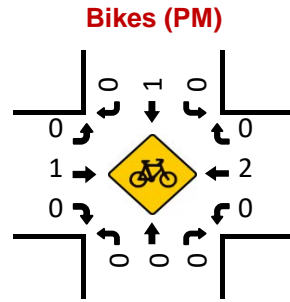
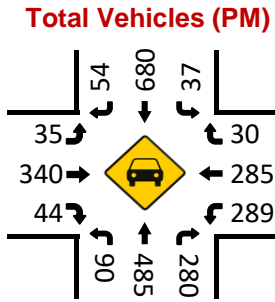
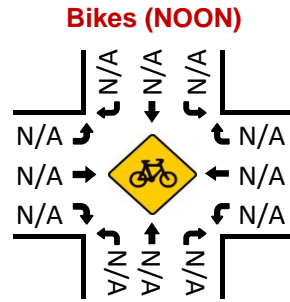
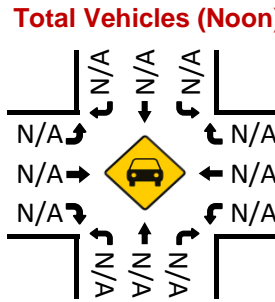
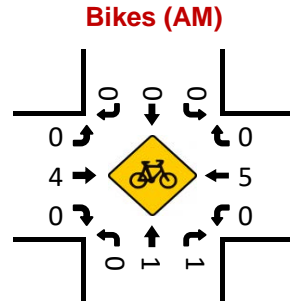
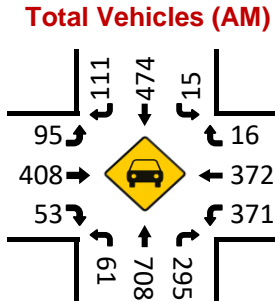
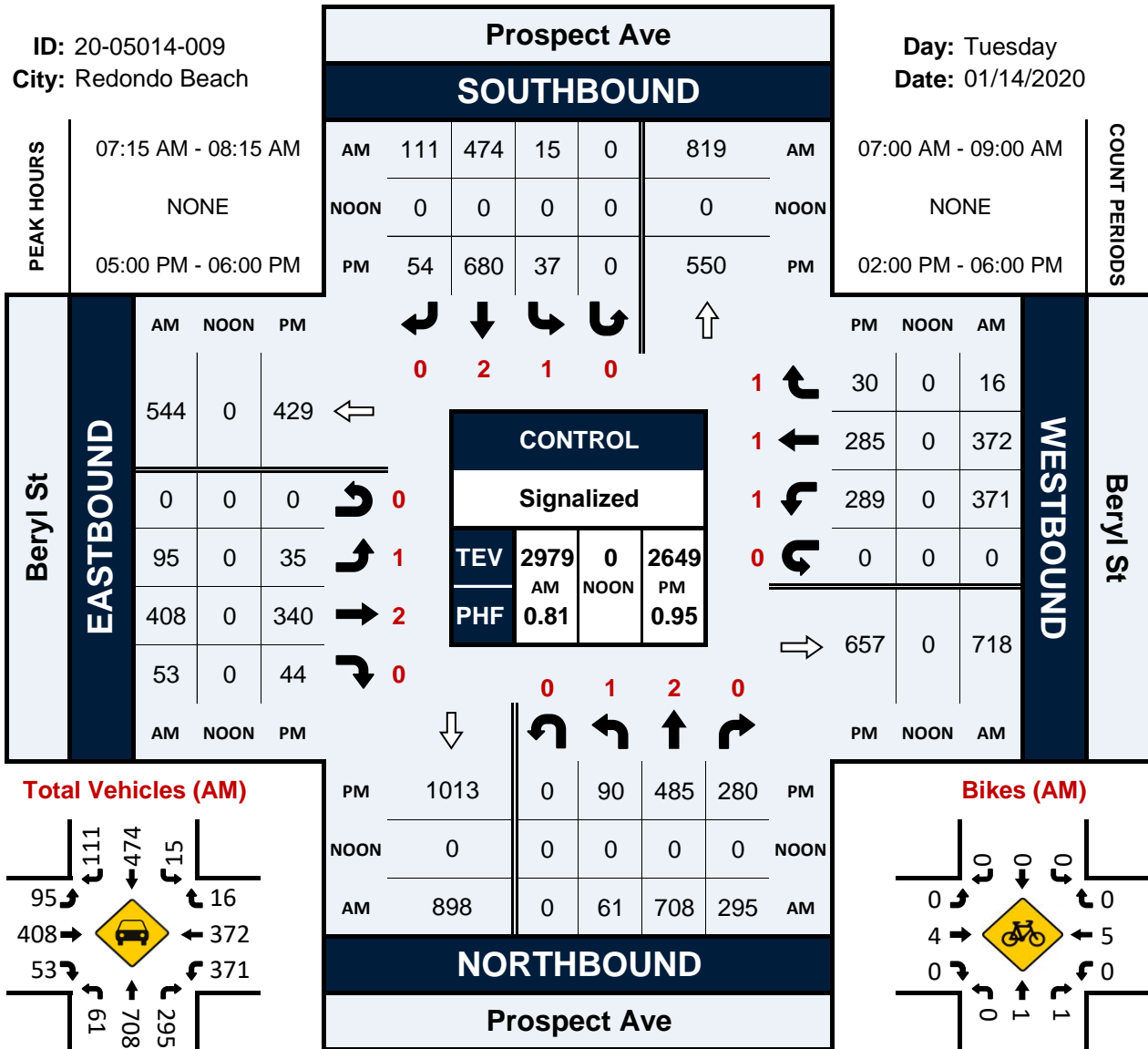

# Harkness Ln & Beryl St

## Peak Hour Turning Movement Count

ID: 20-05014-010  
City: Redondo Beach

Day: Tuesday  
Date: 01/14/2020

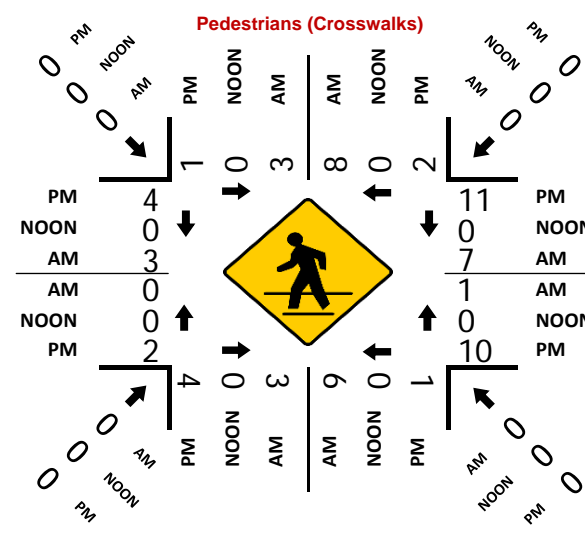
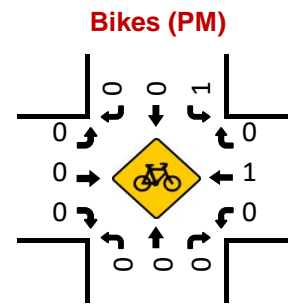
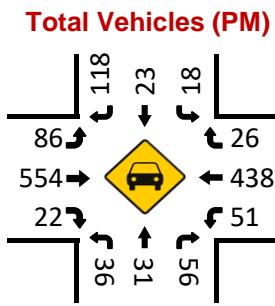
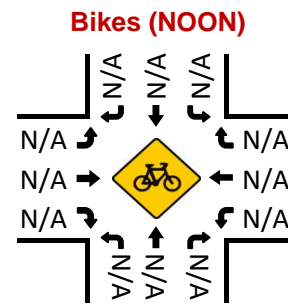
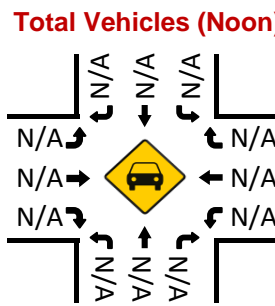
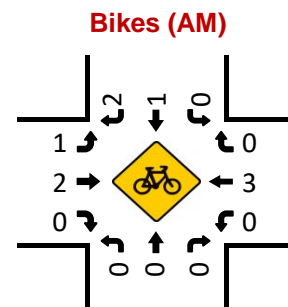
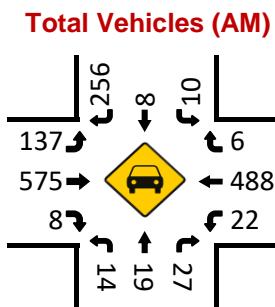
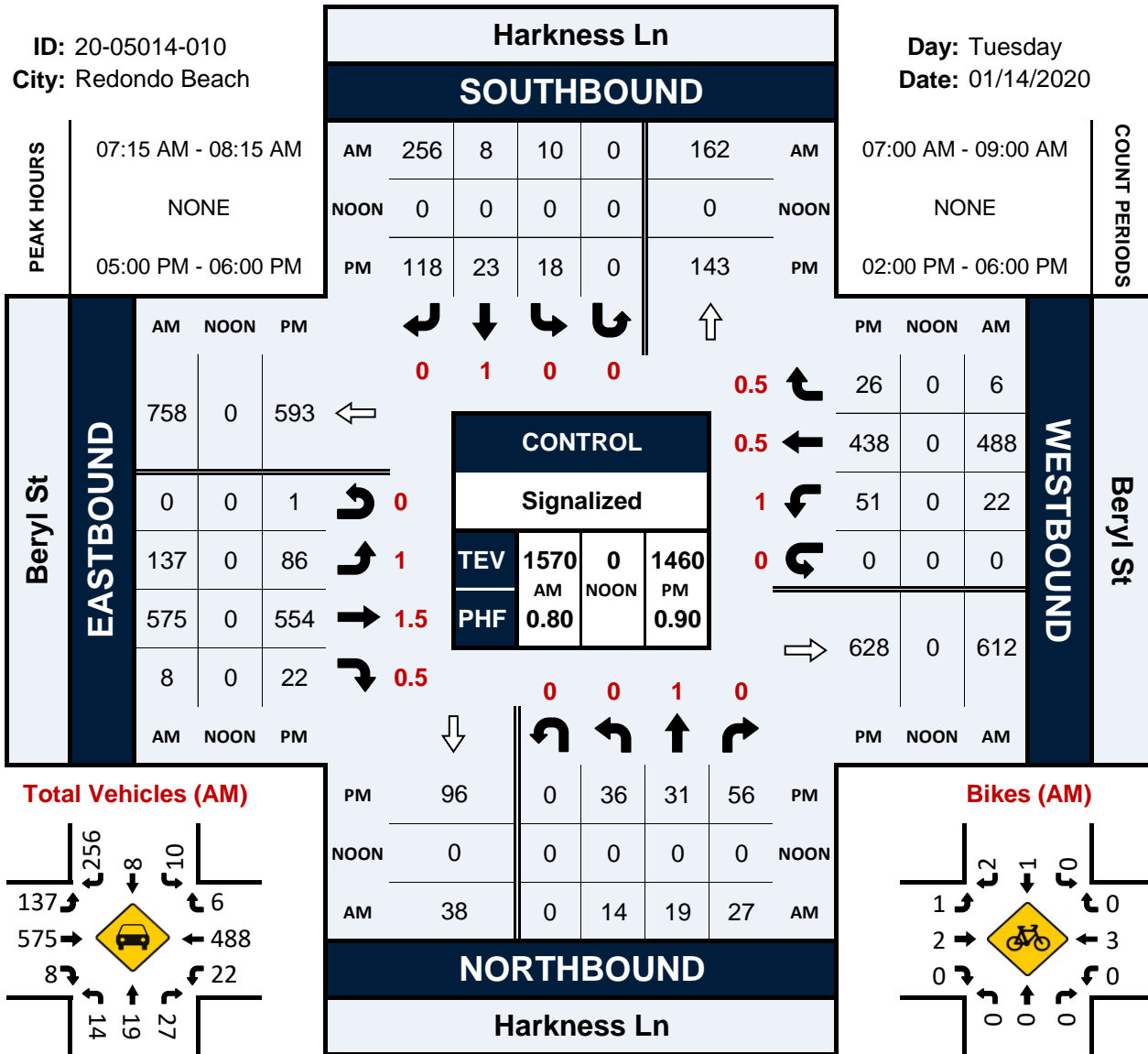



# Flagler Ln & Beryl St

## Peak Hour Turning Movement Count

ID: 20-05014-011  
City: Redondo Beach

Day: Tuesday  
Date: 01/14/2020

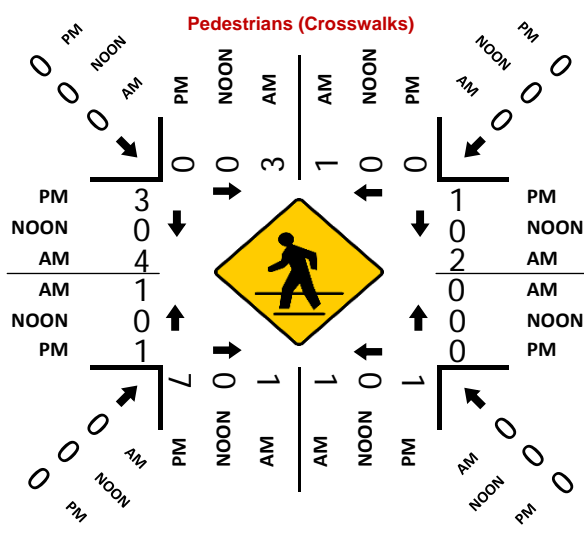
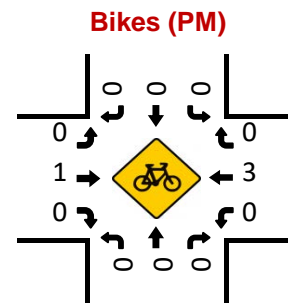
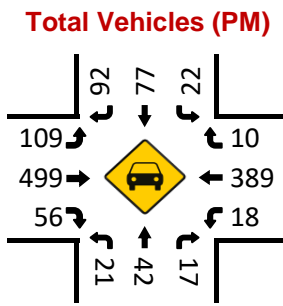
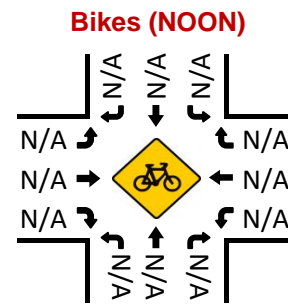
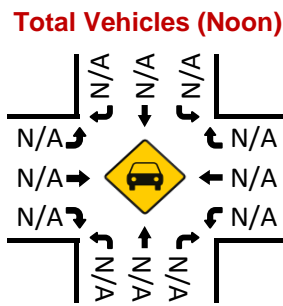
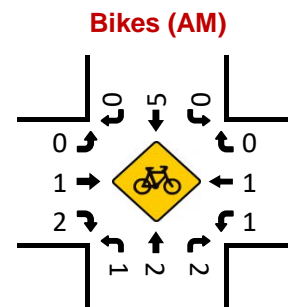
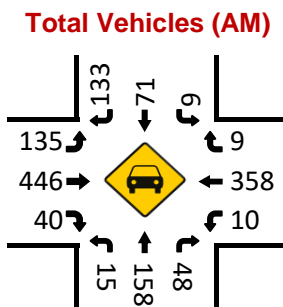
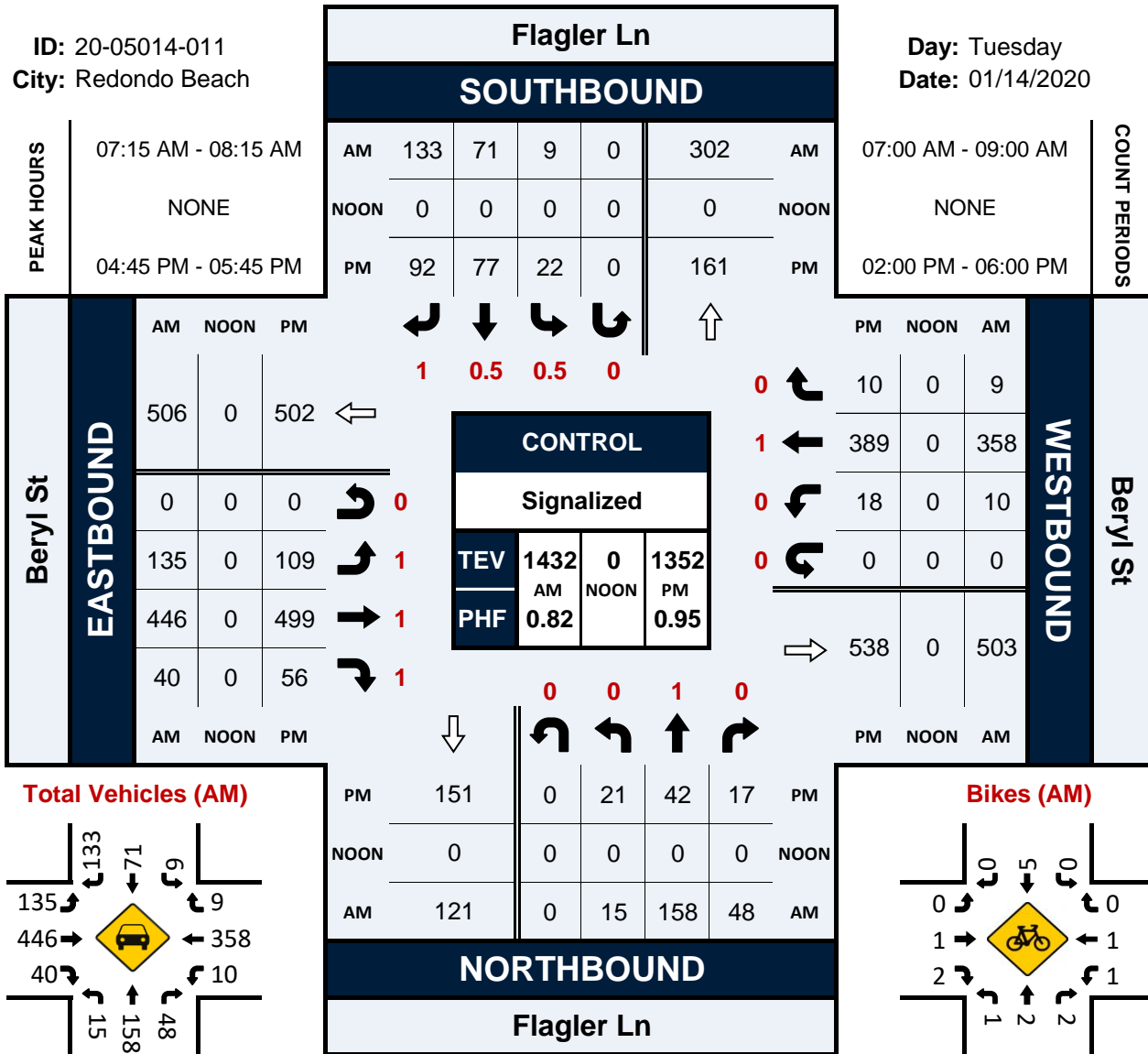

# Prospect Ave & Beach Cities Health District N Campus Dwy

## Peak Hour Turning Movement Count

ID: 20-05014-012  
City: Redondo Beach

Day: Tuesday  
Date: 01/14/2020

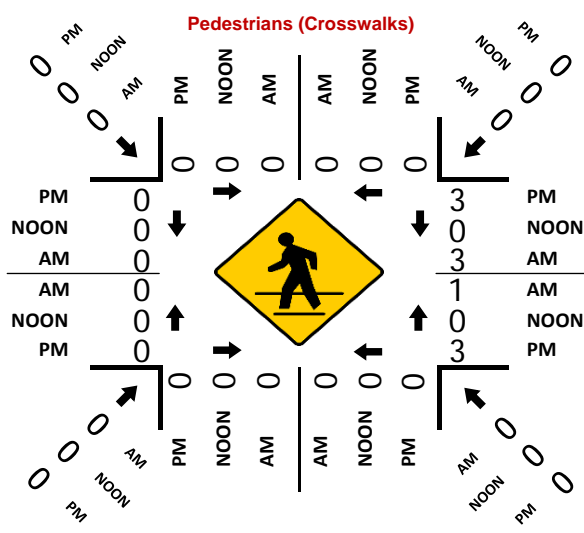
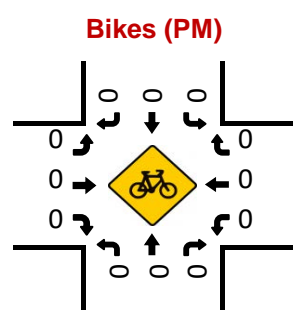
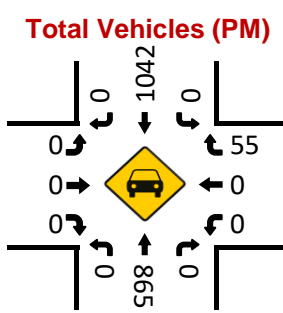
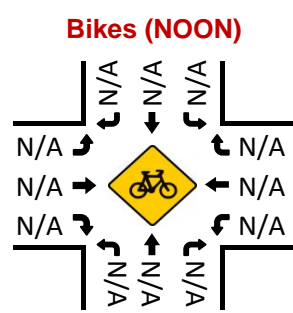
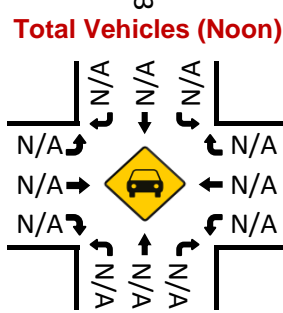
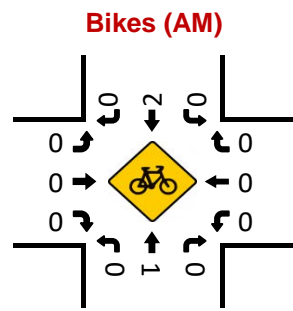
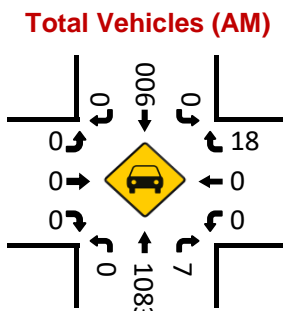
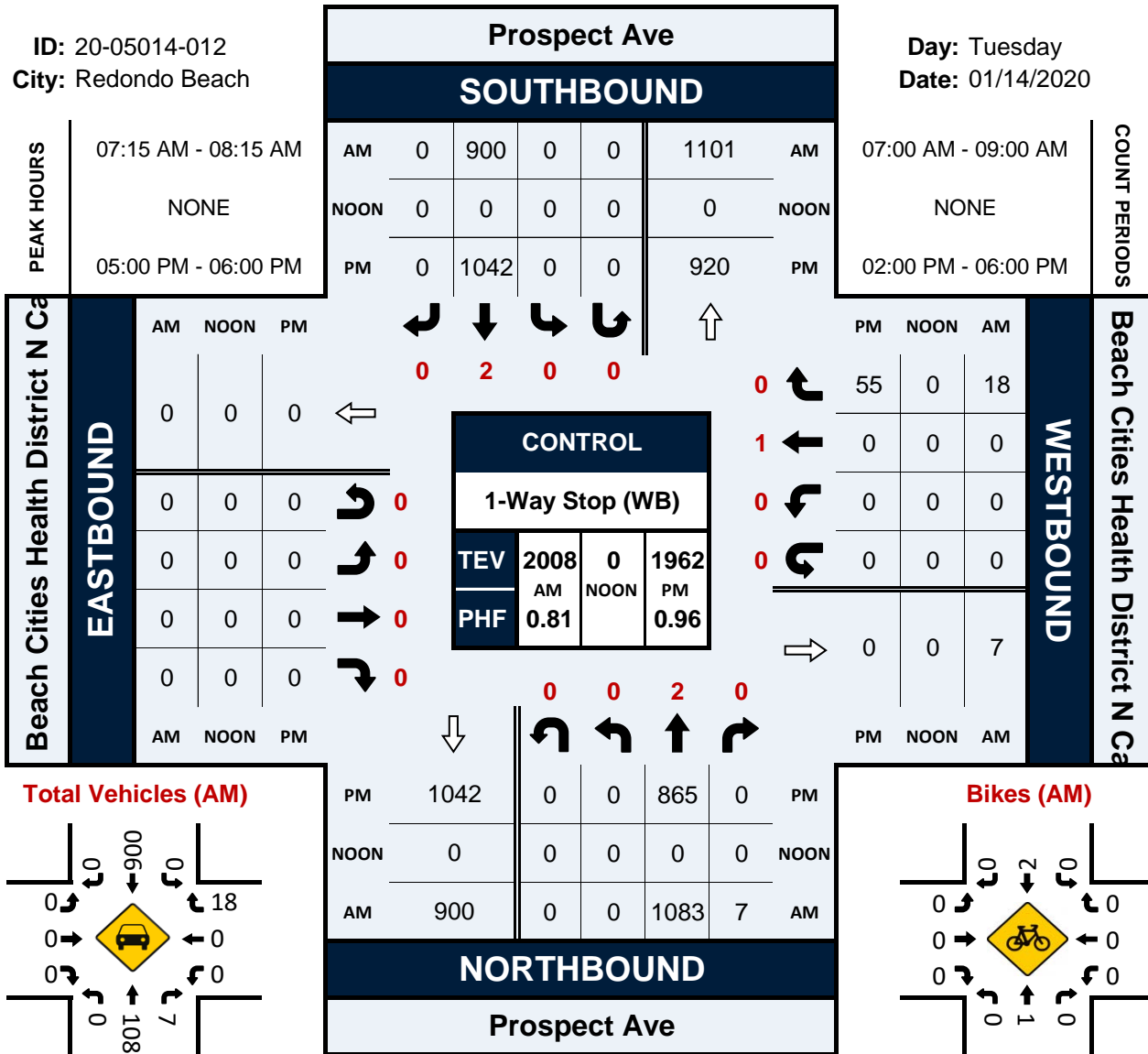

# Prospect Ave & Beach Cities Health District Middle Campus Dwy

## Peak Hour Turning Movement Count

ID: 20-05014-013  
City: Redondo Beach

Day: Tuesday  
Date: 01/14/2020

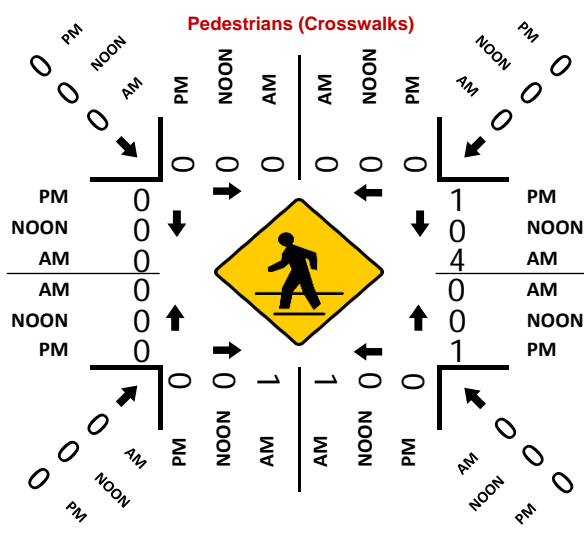
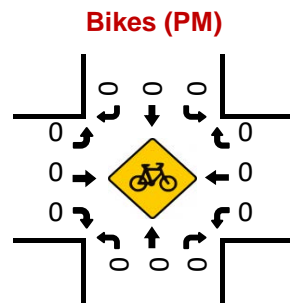
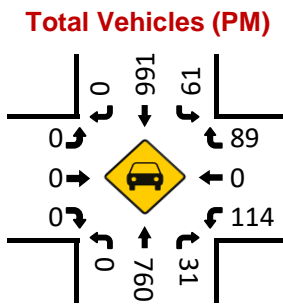
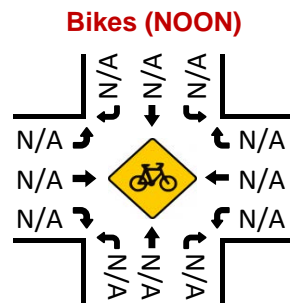
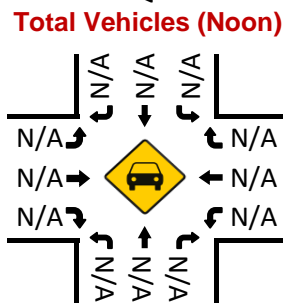
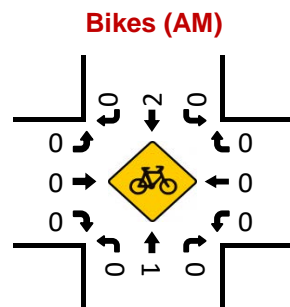
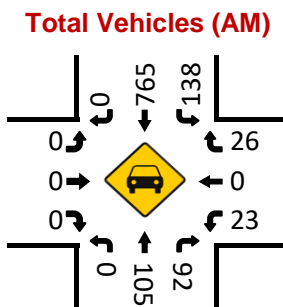
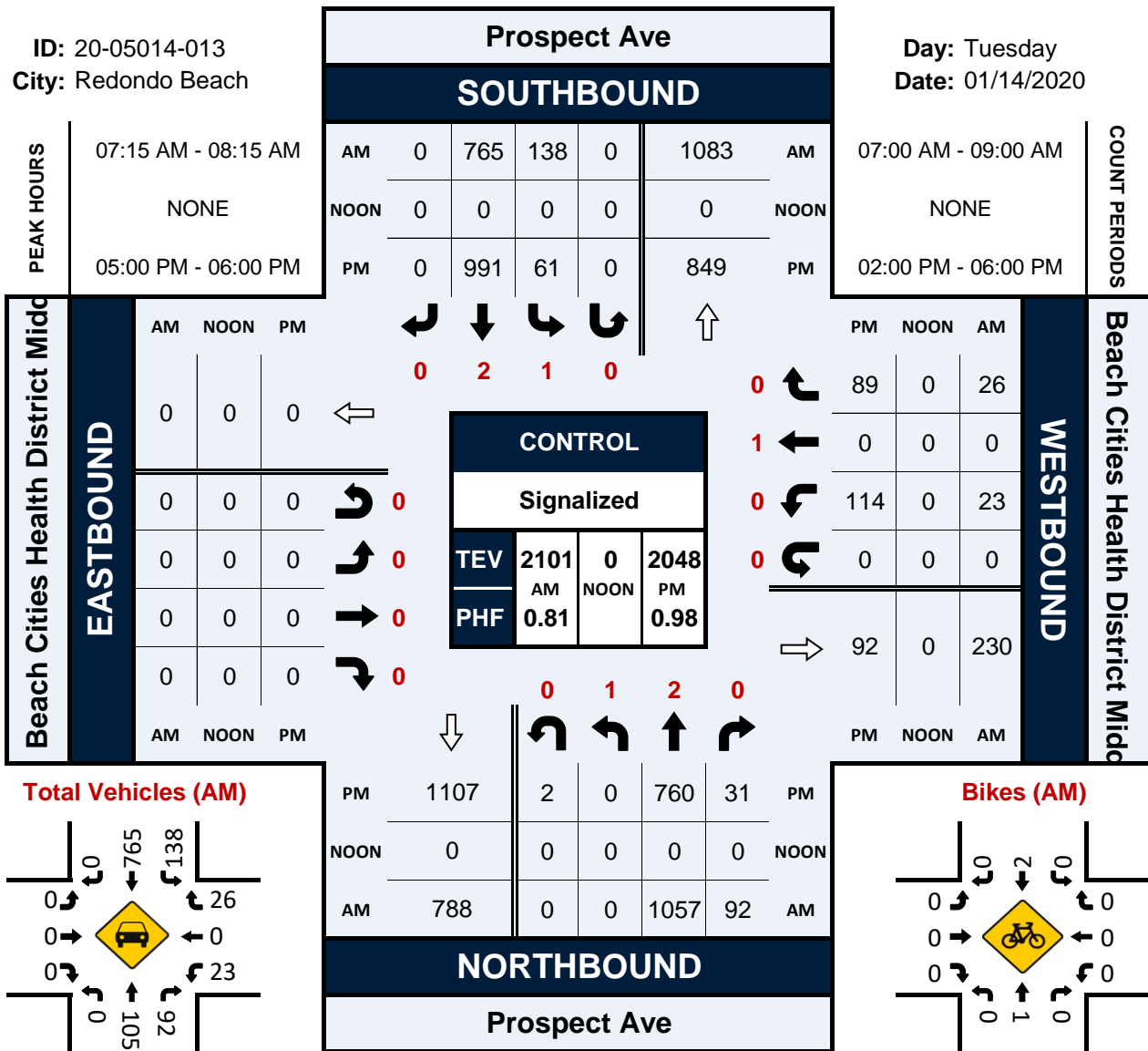

# Prospect Ave & Beach Cities Health District S Campus Dwy

## Peak Hour Turning Movement Count

ID: 20-05014-014  
City: Redondo Beach

Day: Tuesday  
Date: 01/14/2020

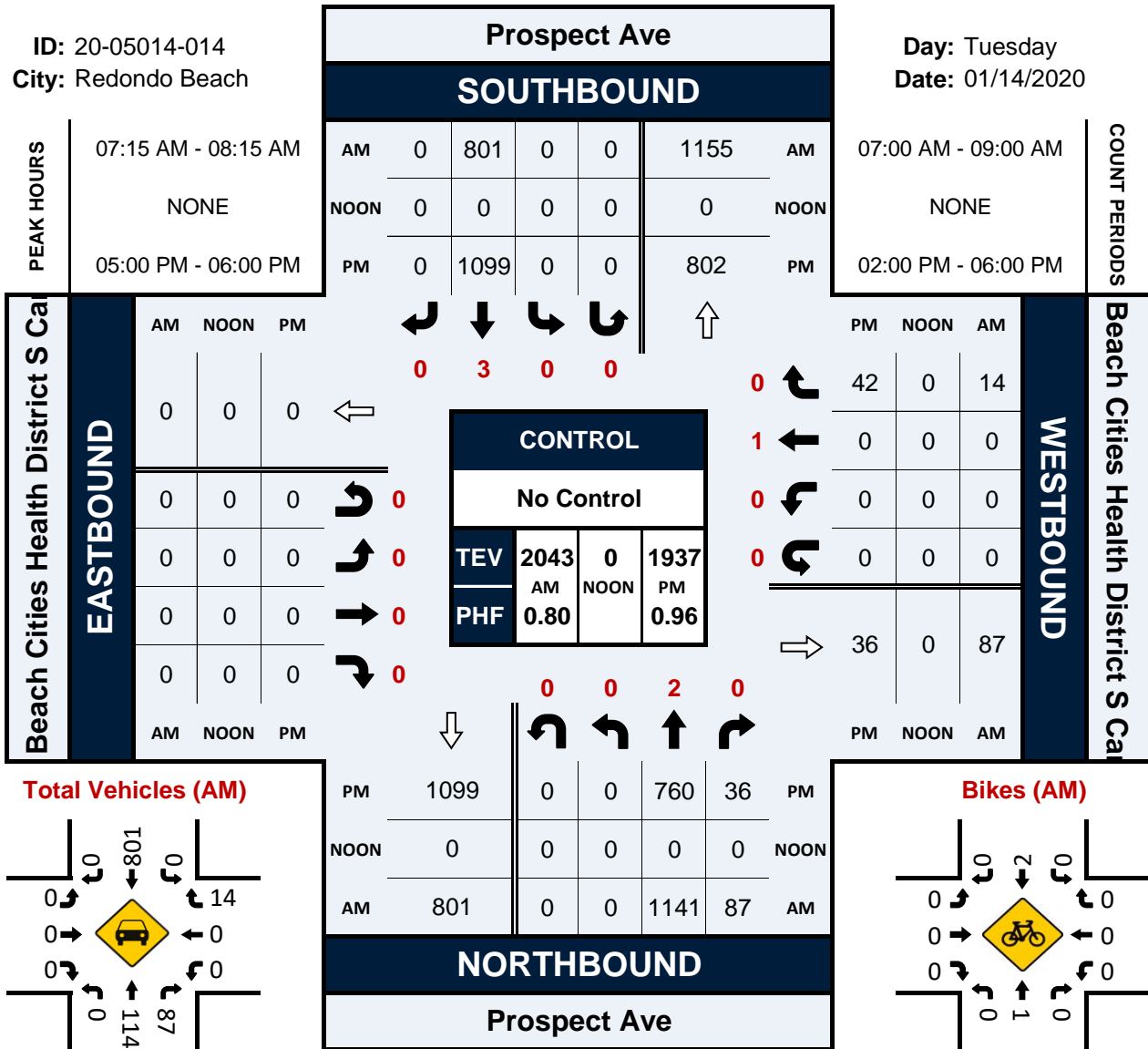

**Total Vehicles (AM)**

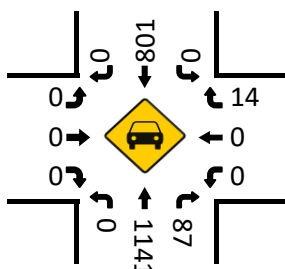

**Total Vehicles (Noon)**

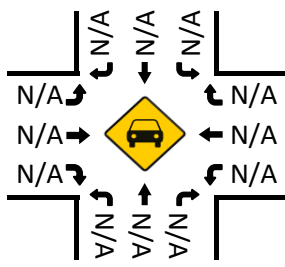

**Total Vehicles (PM)**

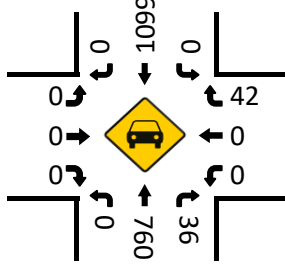

**Bikes (AM)**

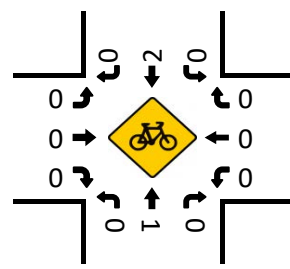

**Bikes (NOON)**

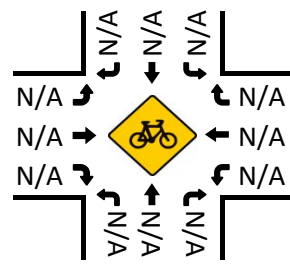

**Bikes (PM)**

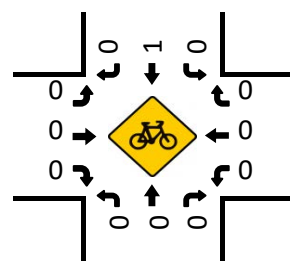

**Pedestrians (Crosswalks)**

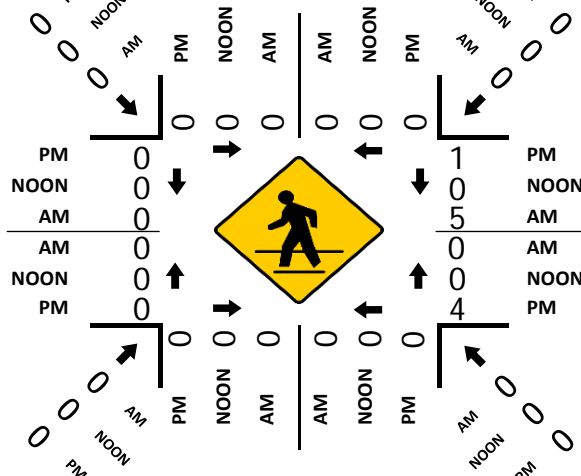

# Prospect Ave & Diamond St

## Peak Hour Turning Movement Count

ID: 20-05014-015  
City: Redondo Beach

Day: Tuesday  
Date: 01/14/2020

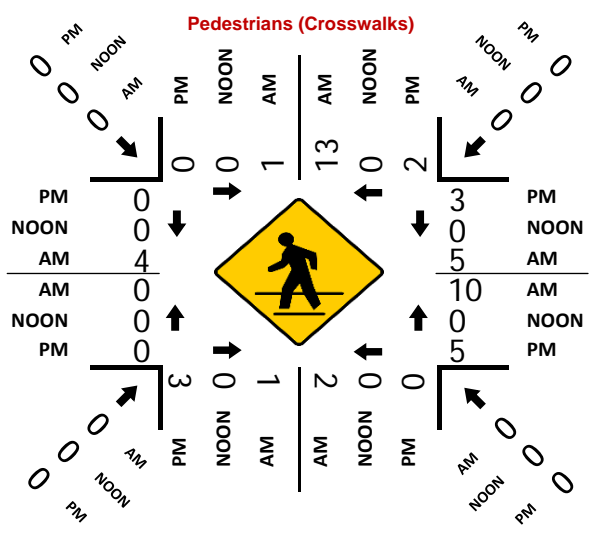
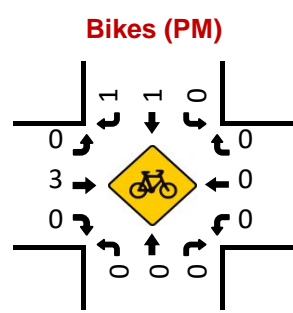
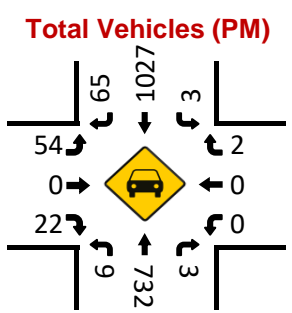
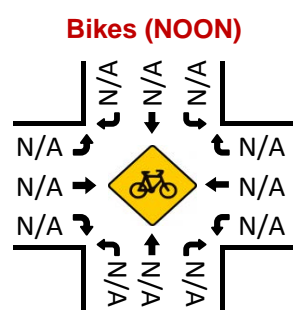
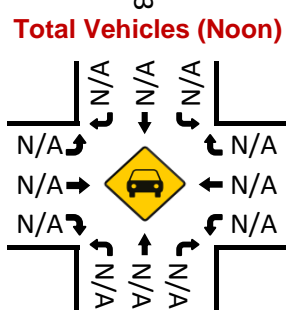
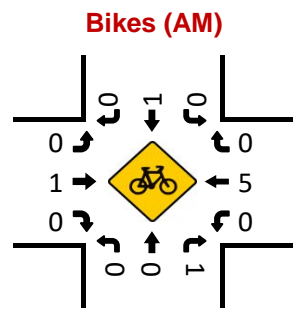
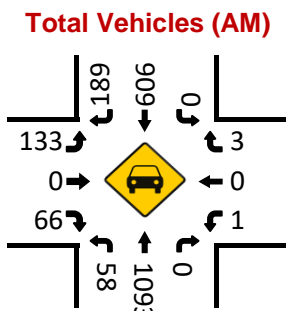
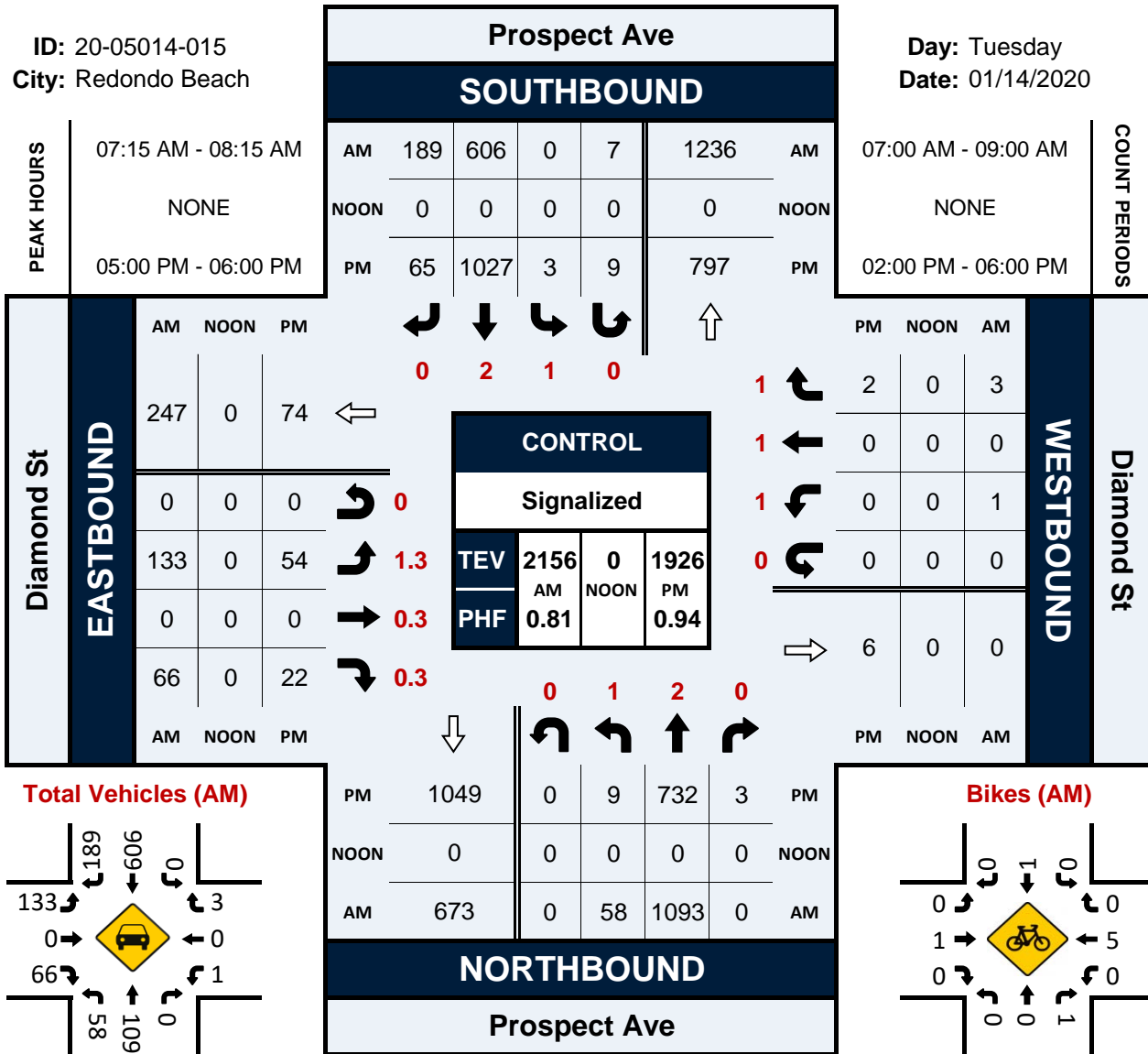

# Anza Ave & Halison St

## Peak Hour Turning Movement Count

ID: 20-05014-016  
City: Torrance

Day: Tuesday  
Date: 01/14/2020

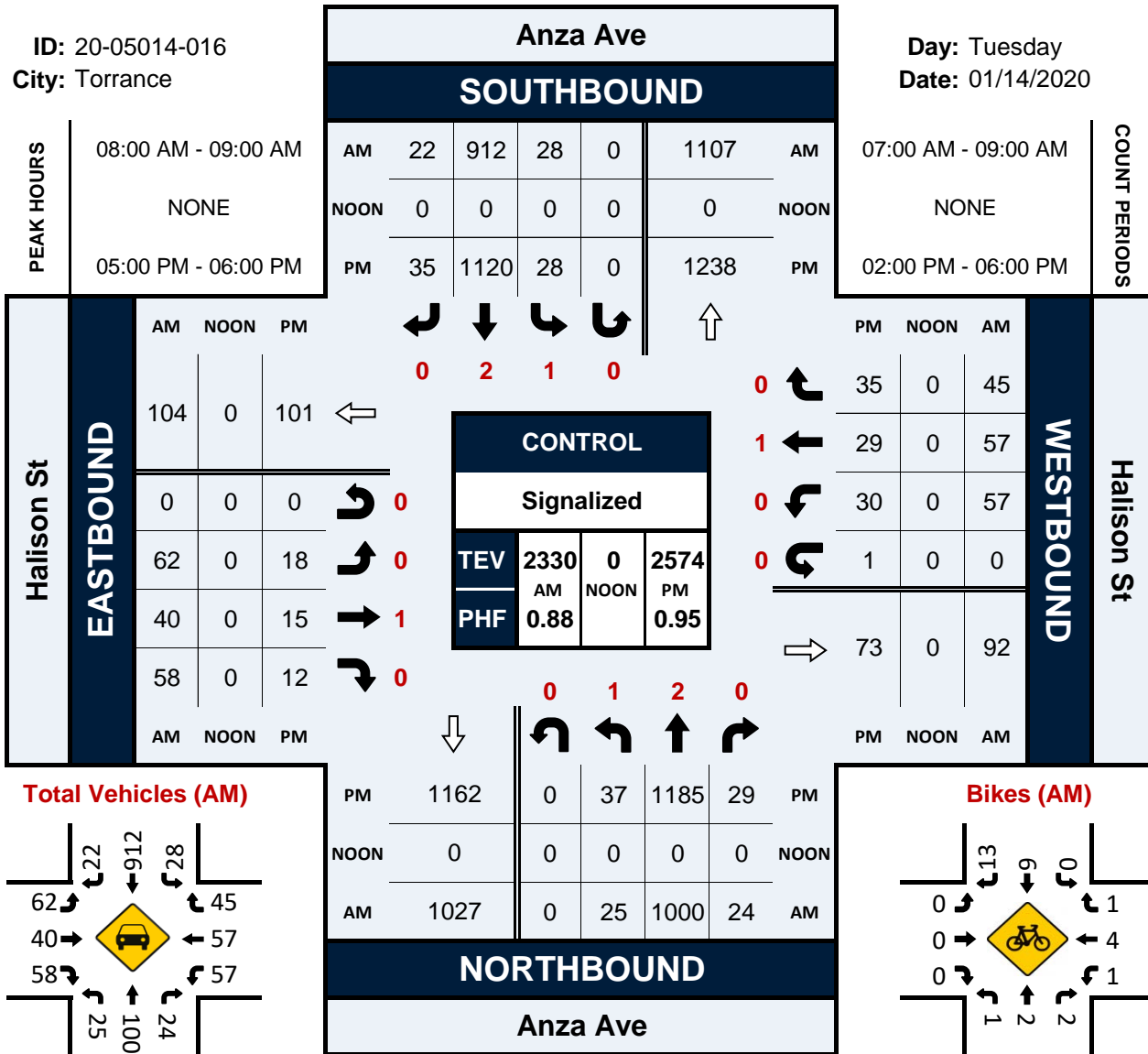

**PEAK HOURS**

08:00 AM - 09:00 AM
NONE
05:00 PM - 06:00 PM

**COUNT PERIODS**

07:00 AM - 09:00 AM
NONE
02:00 PM - 06:00 PM

**Halison St EASTBOUND**

AM	NOON	PM
104	0	101
0	0	0
62	0	18
40	0	15
58	0	12

**Halison St WESTBOUND**

PM	NOON	AM
35	0	45
29	0	57
30	0	57
1	0	0
73	0	92

**Anza Ave SOUTHBOUND**

AM	NOON	PM	TOTAL
22	0	35	57
912	0	1120	2032
28	0	28	56
0	0	0	0
<b>1107</b>			
<b>0</b>			
<b>1238</b>			

**Anza Ave NORTHBOUND**

PM	NOON	AM	TOTAL
1162	0	1027	2189
0	0	0	0
37	0	25	62
1185	0	1000	2185
29	0	24	53

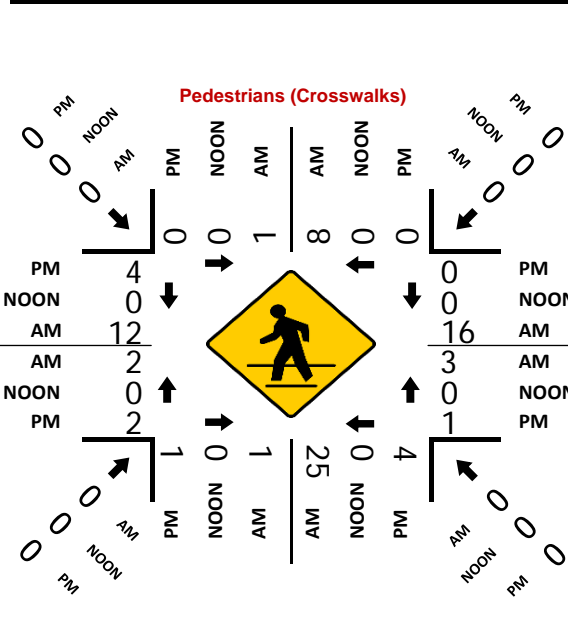
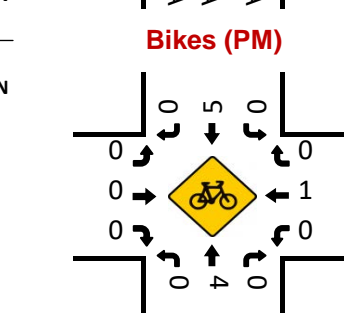
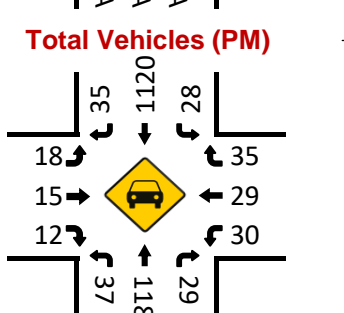
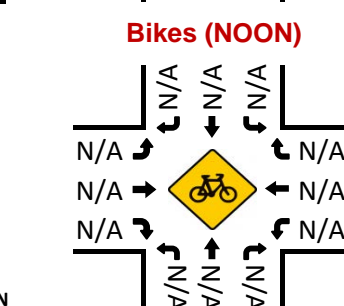
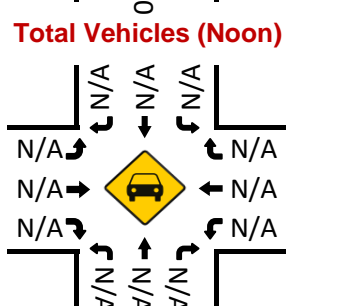
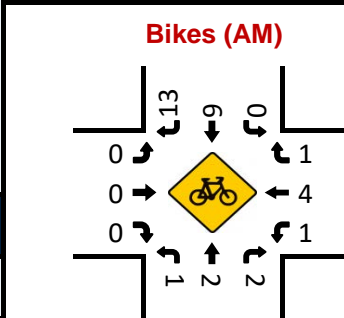
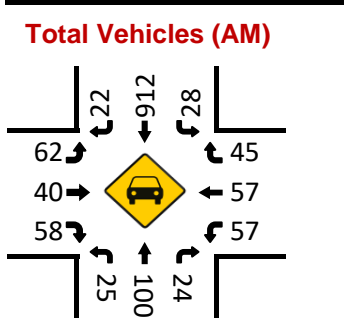

# Prospect Ave & Del Amo Blvd

## Peak Hour Turning Movement Count

ID: 20-05014-017  
City: Redondo Beach

Day: Tuesday  
Date: 01/14/2020

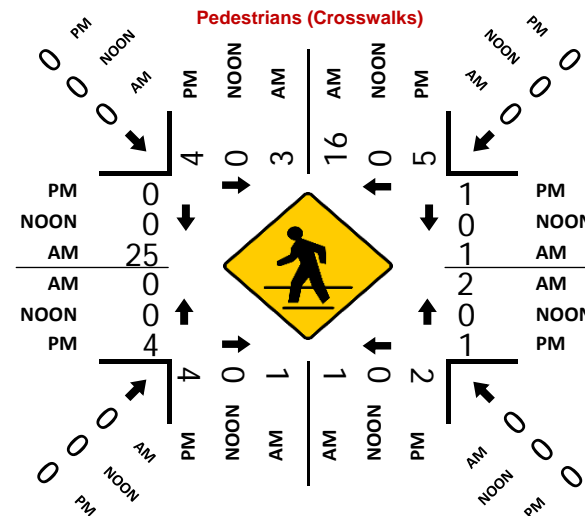
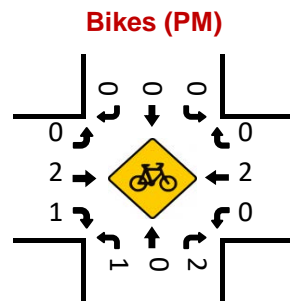
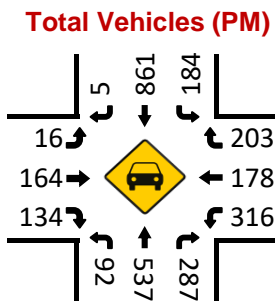
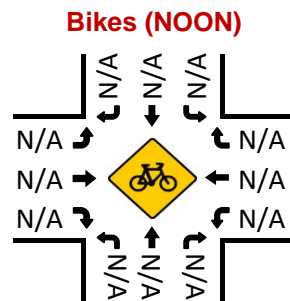
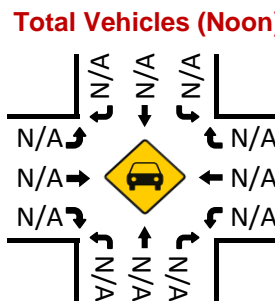
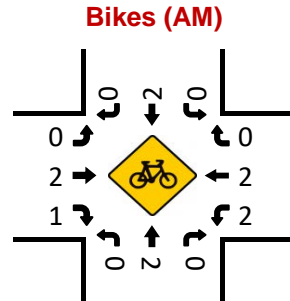
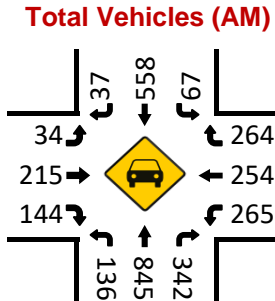
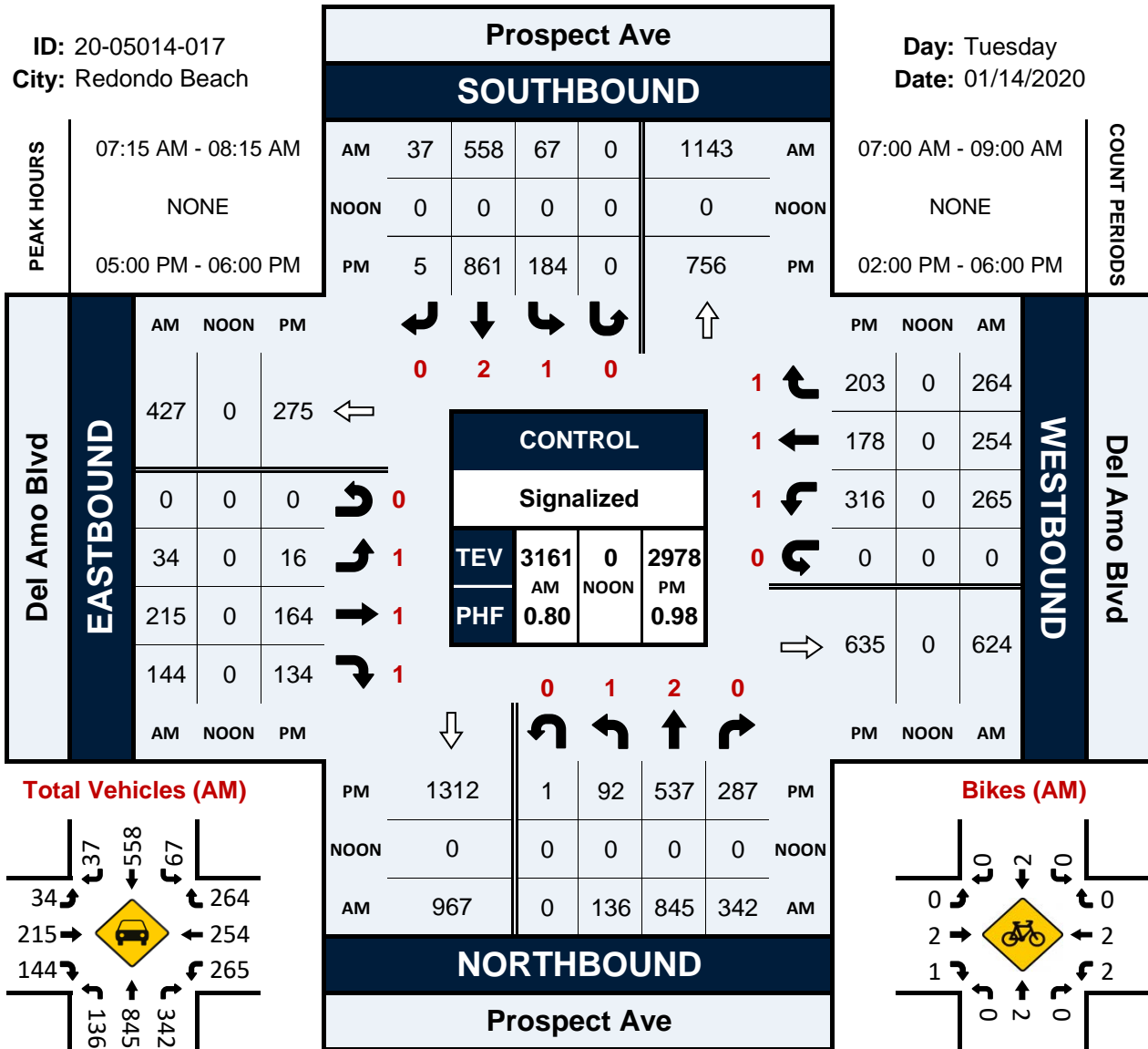

# Redbeam Ave & Del Amo Blvd

## Peak Hour Turning Movement Count

ID: 20-05014-018  
City: Redondo Beach

Day: Tuesday  
Date: 01/14/2020

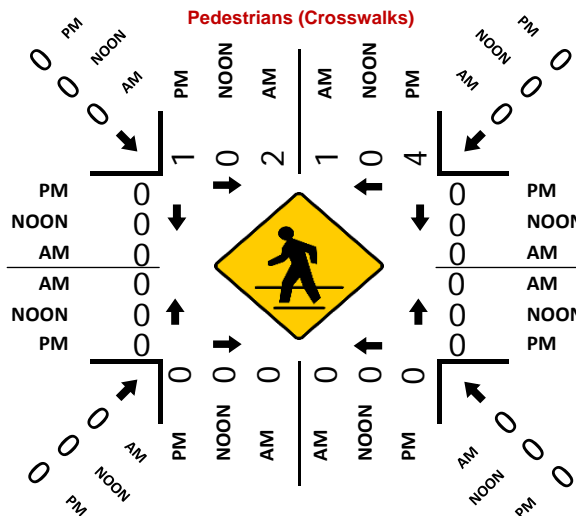
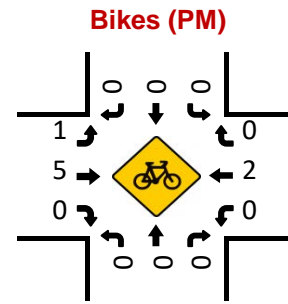
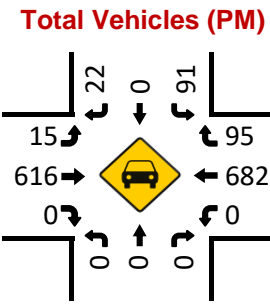
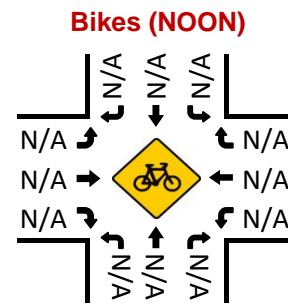
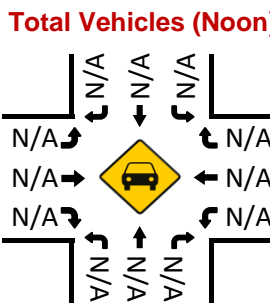
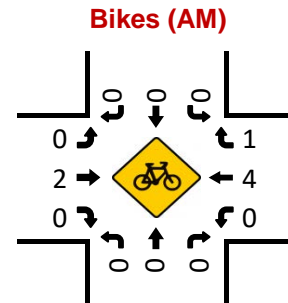
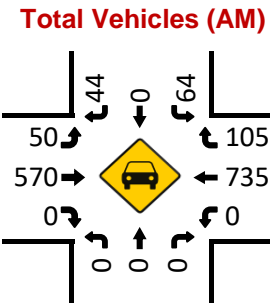
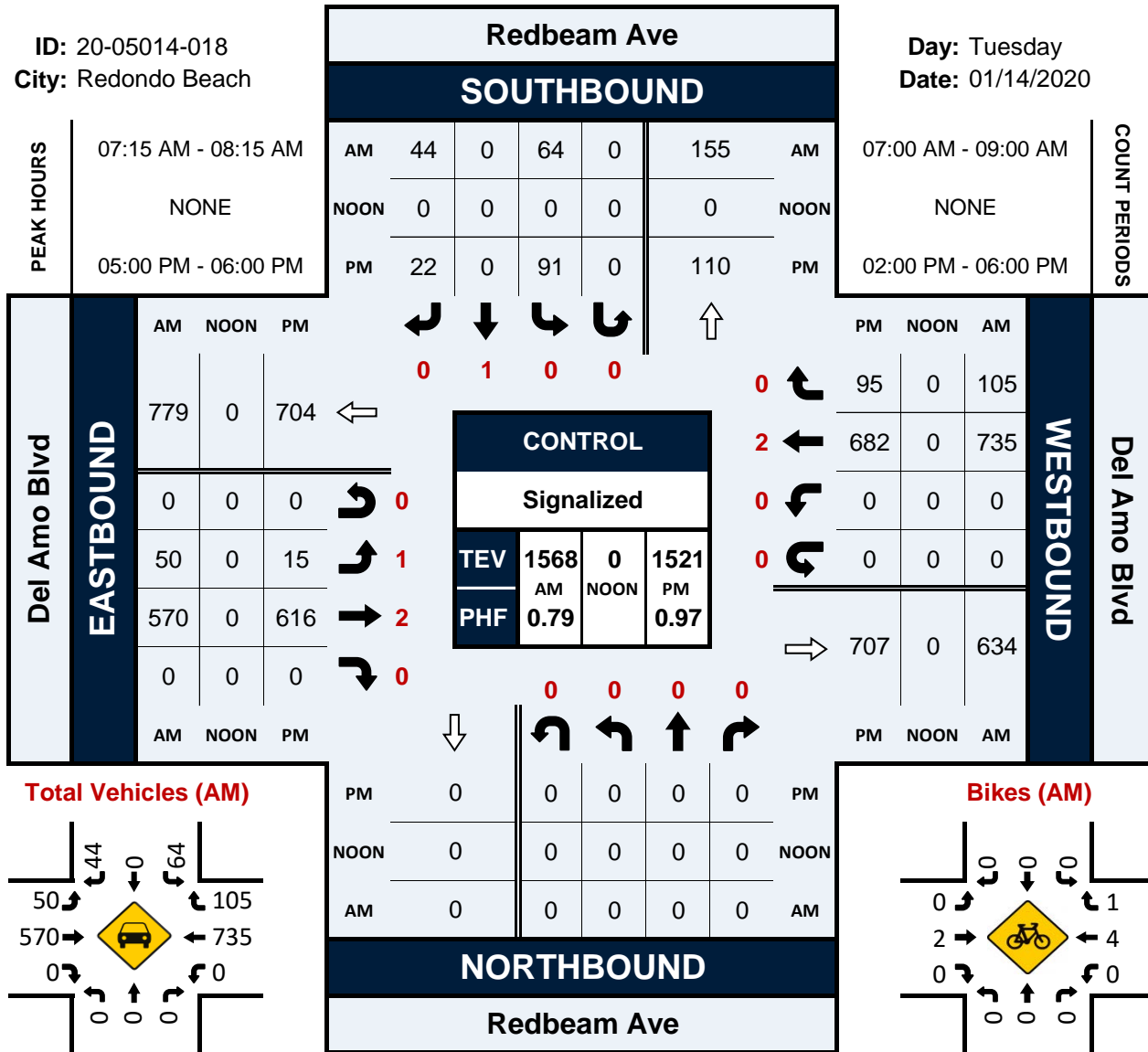



# Wayne Ave & Del Amo Blvd

## Peak Hour Turning Movement Count

ID: 20-05014-019  
City: Torrance

Day: Tuesday  
Date: 01/14/2020

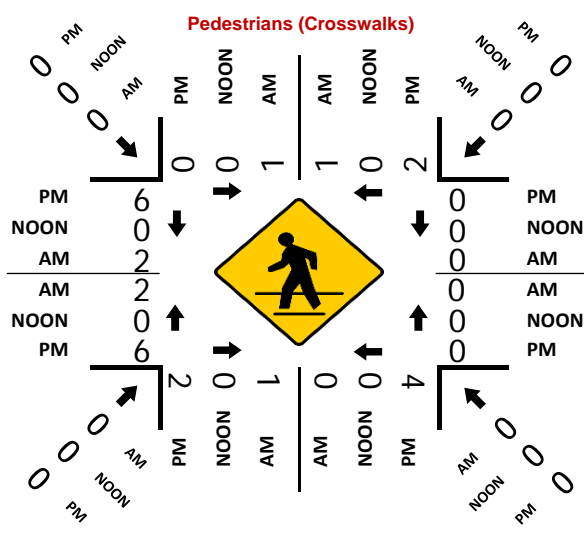
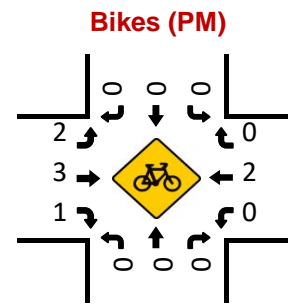
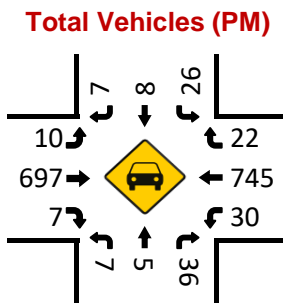
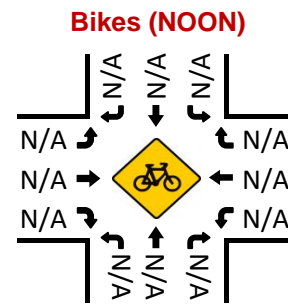
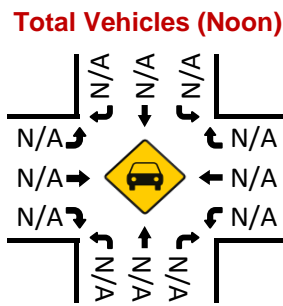
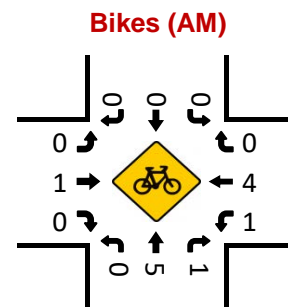
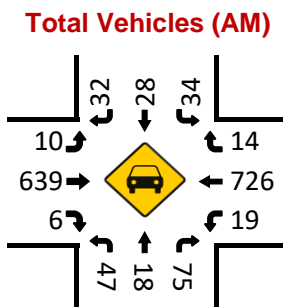
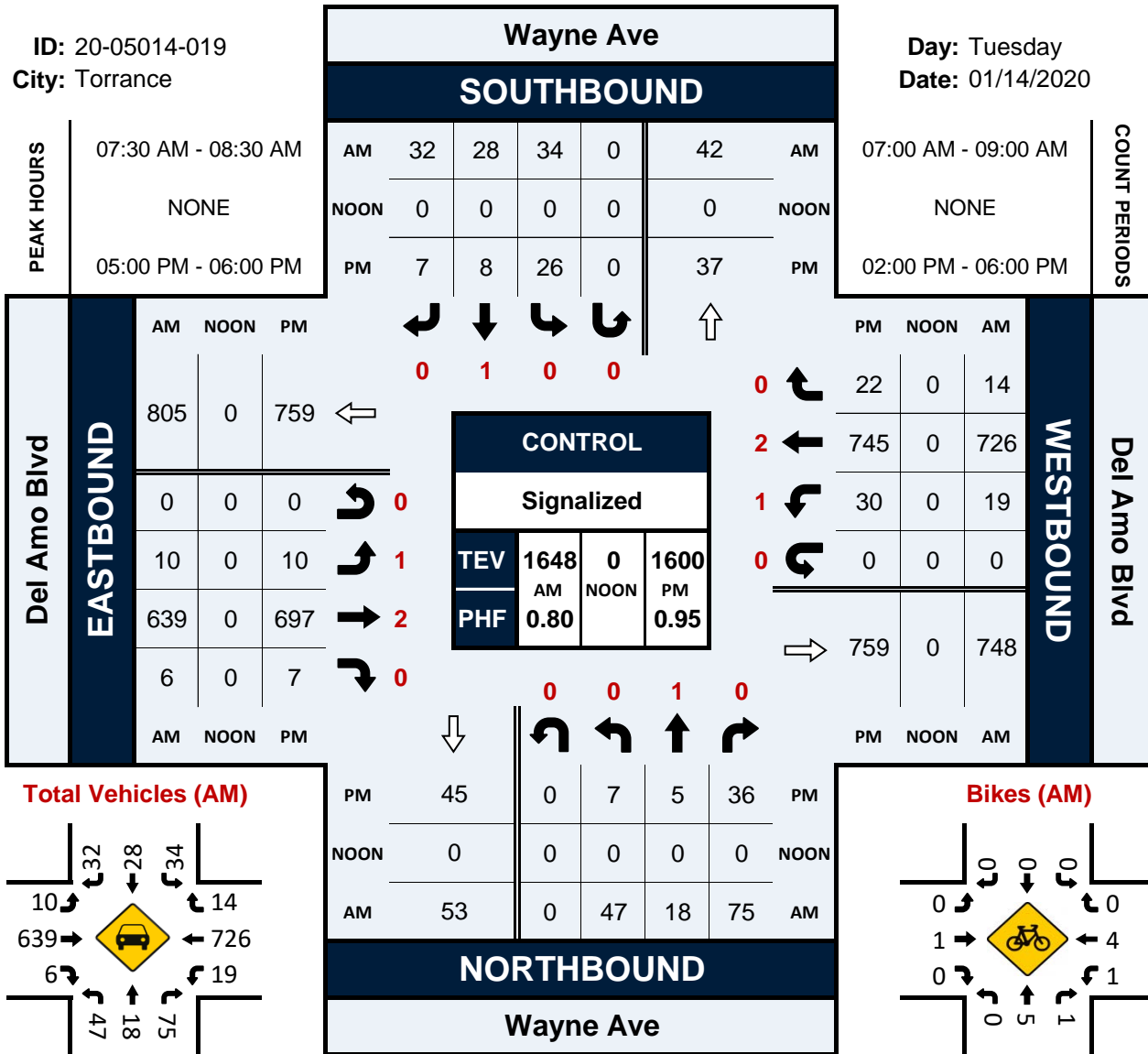

# Henrietta St & Del Amo Blvd

## Peak Hour Turning Movement Count

ID: 20-05014-020  
 City: Torrance

Day: Tuesday  
 Date: 01/14/2020

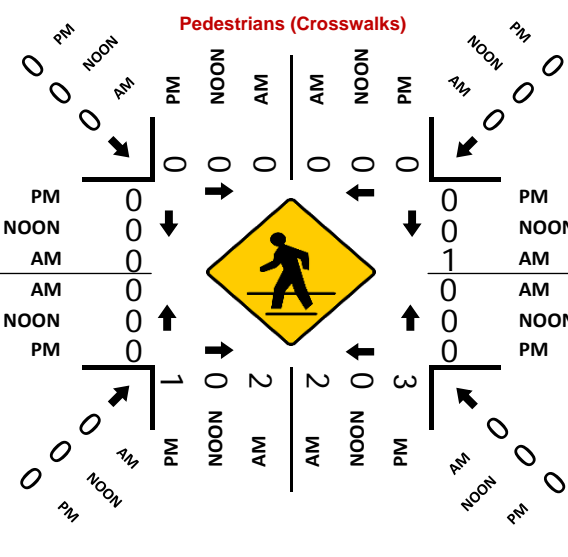
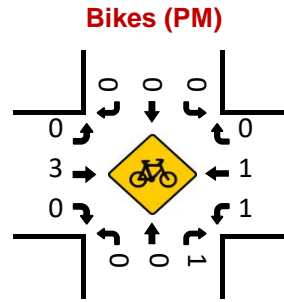
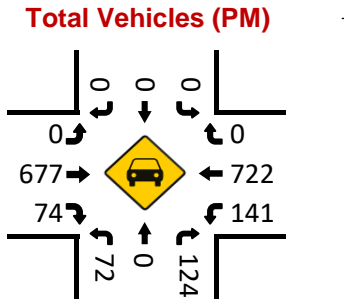
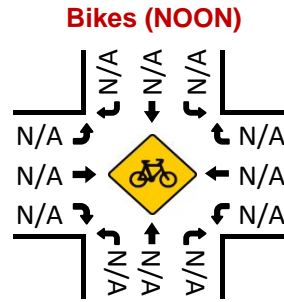
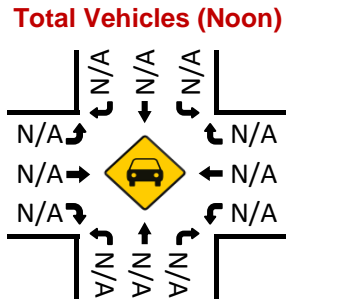
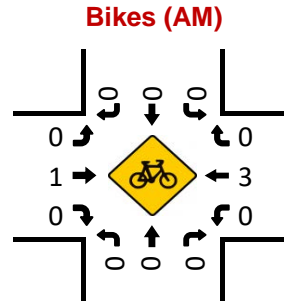
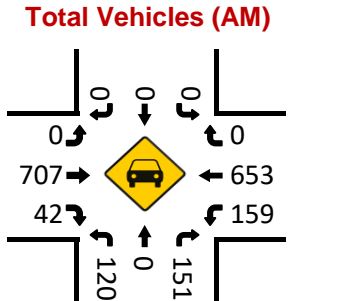
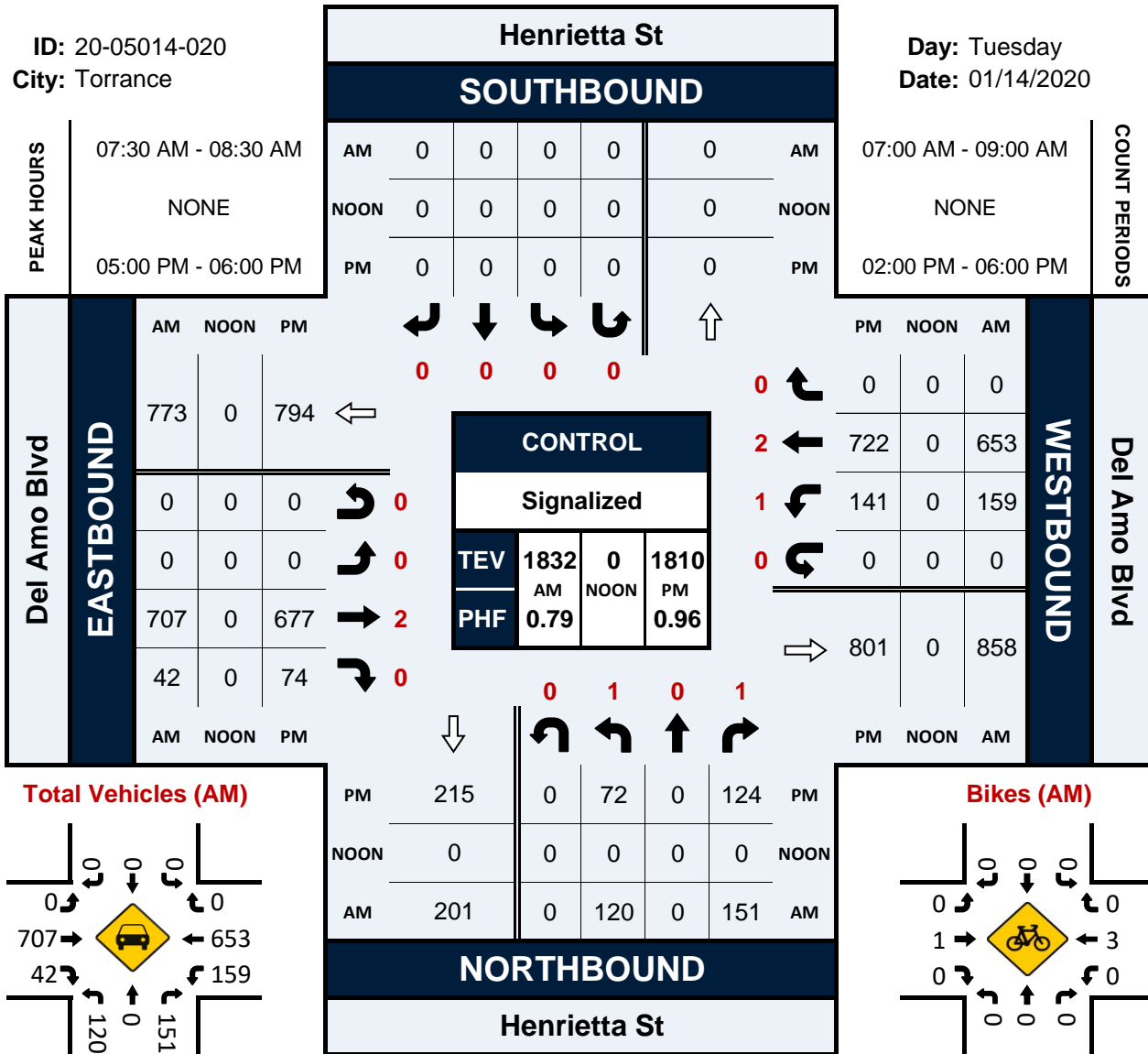

# Entradero Ave & Del Amo Blvd

## Peak Hour Turning Movement Count

ID: 20-05014-021  
City: Torrance

Day: Tuesday  
Date: 01/14/2020

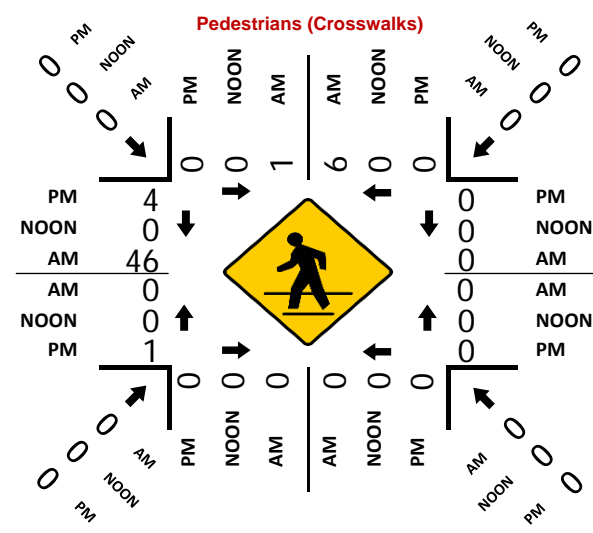
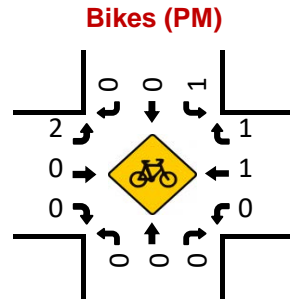
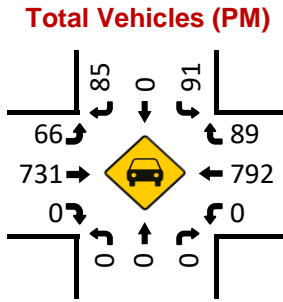
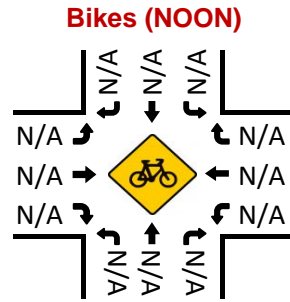
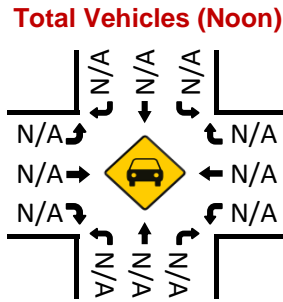
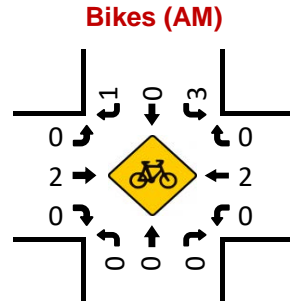
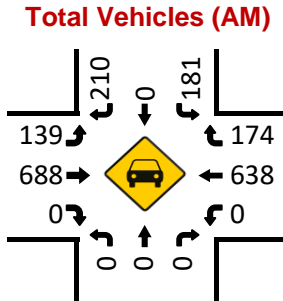
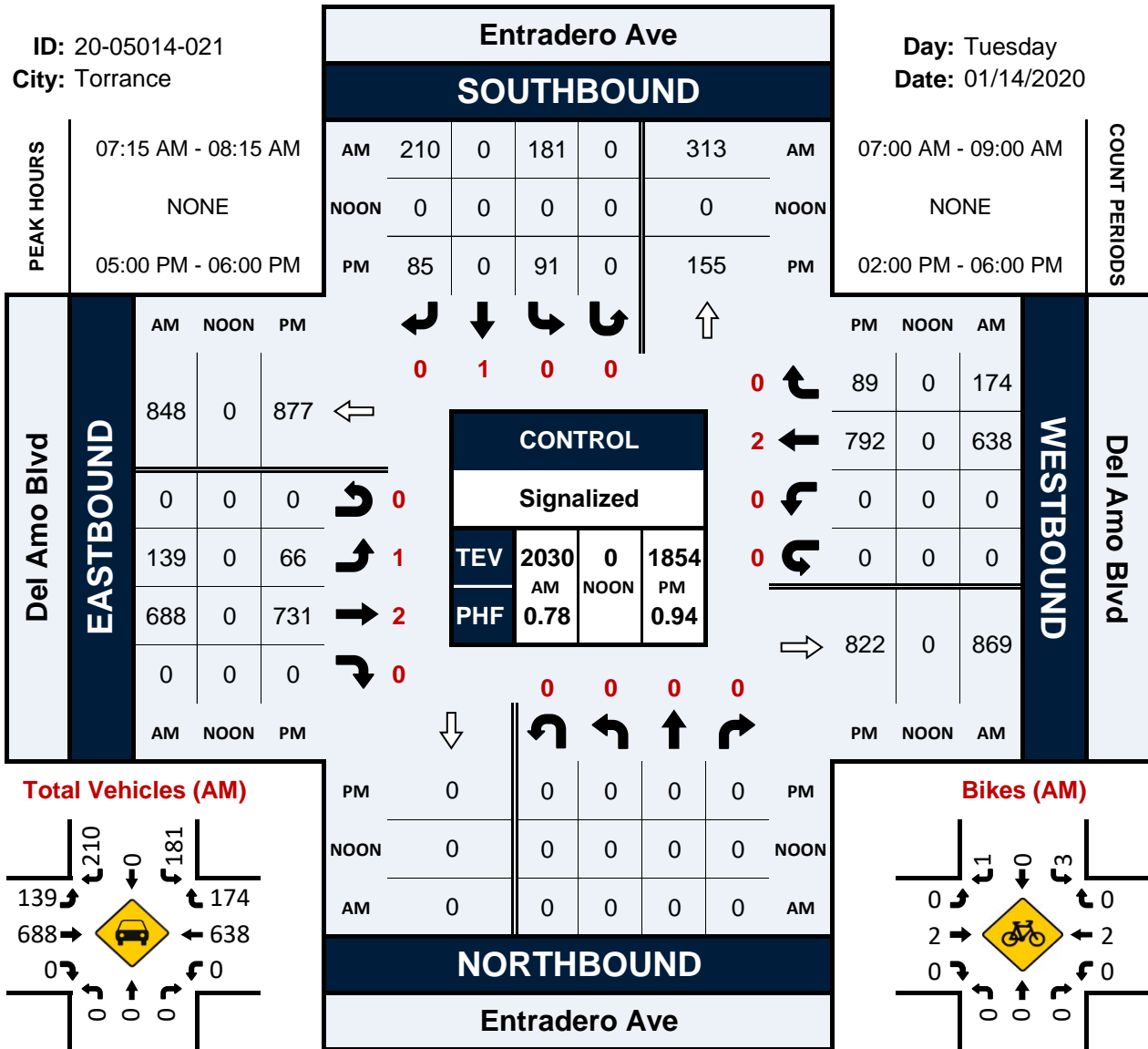

# Victor St & Del Amo Blvd

## Peak Hour Turning Movement Count

ID: 20-05014-022  
City: Torrance

Day: Tuesday  
Date: 01/14/2020

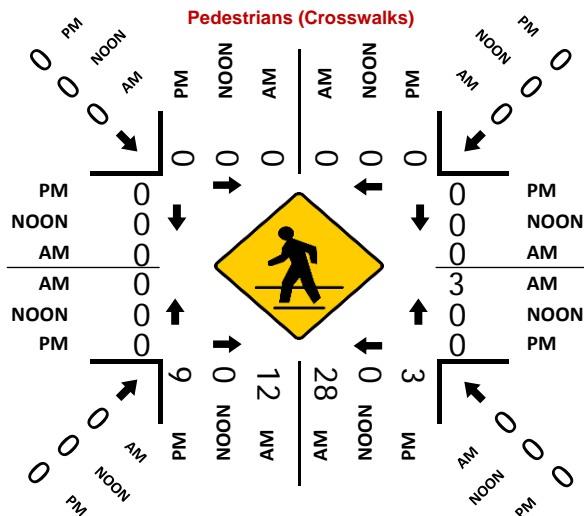
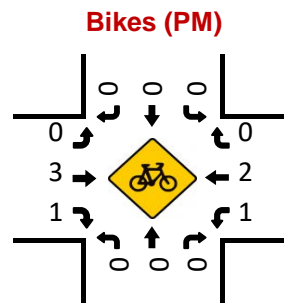
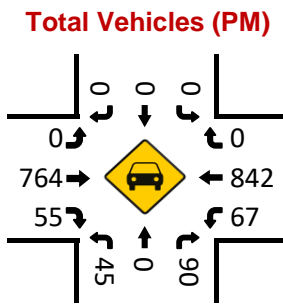
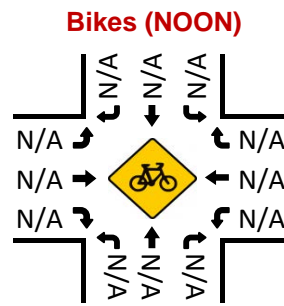
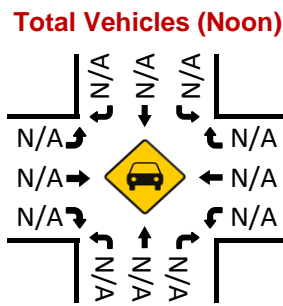
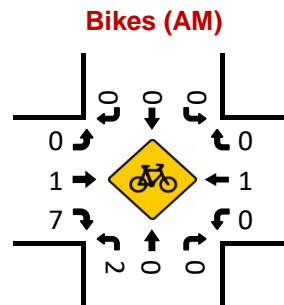
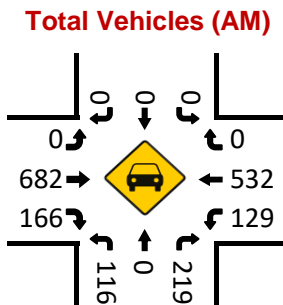
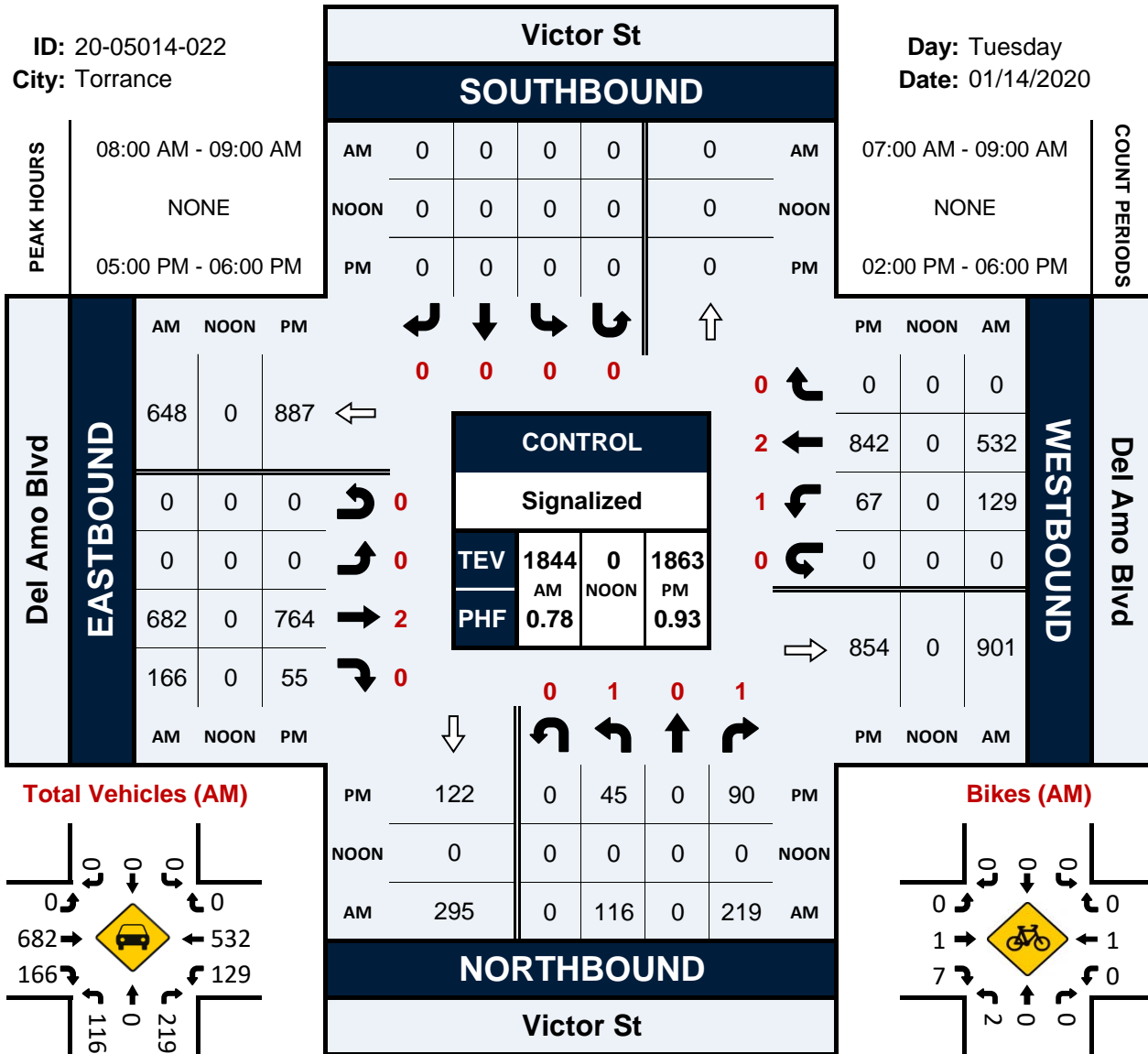

# Anza Ave & Del Amo Blvd

## Peak Hour Turning Movement Count

ID: 20-05014-023  
City: Torrance

Day: Tuesday  
Date: 01/14/2020

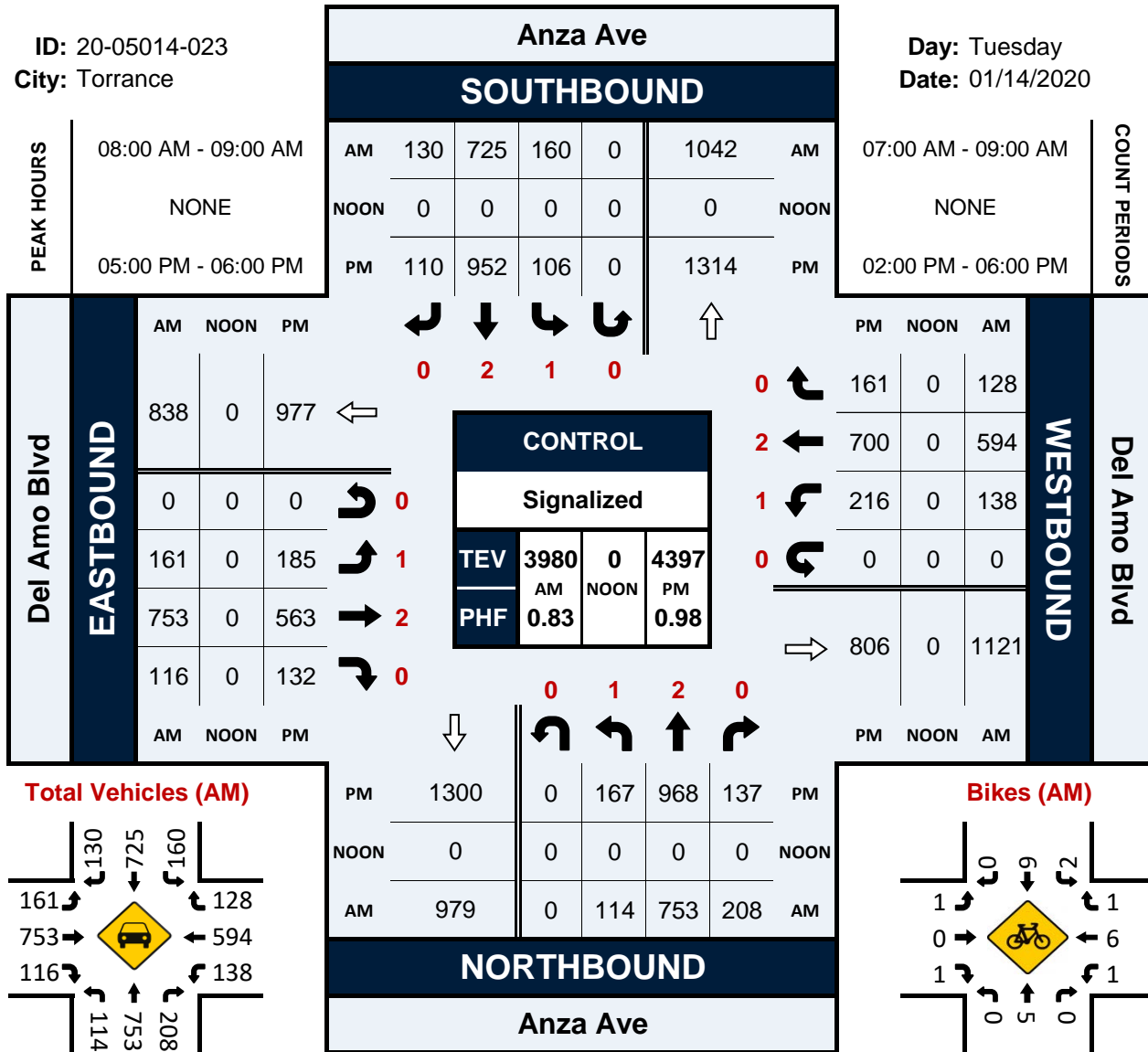

**PEAK HOURS**

08:00 AM - 09:00 AM
NONE
05:00 PM - 06:00 PM

**COUNT PERIODS**

07:00 AM - 09:00 AM
NONE
02:00 PM - 06:00 PM

**Del Amo Blvd EASTBOUND**

	AM	NOON	PM
Left	838	0	977
Through	0	0	0
Right	161	0	185
Left	753	0	563
Right	116	0	132

**Anza Ave SOUTHBOUND**

	AM	NOON	PM
Left	130	0	110
Through	725	0	952
Right	160	0	106
Total	1042	0	1314

**Anza Ave NORTHBOUND**

	AM	NOON	PM
Left	0	0	0
Through	0	0	0
Right	0	0	0
Total	0	0	0

**Del Amo Blvd WESTBOUND**

	PM	NOON	AM
Left	161	0	128
Through	700	0	594
Right	216	0	138
Left	0	0	0
Through	806	0	1121

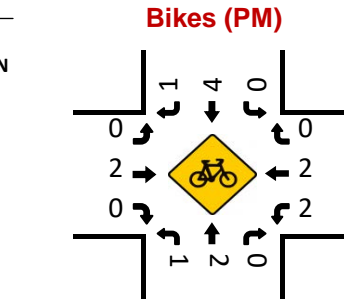
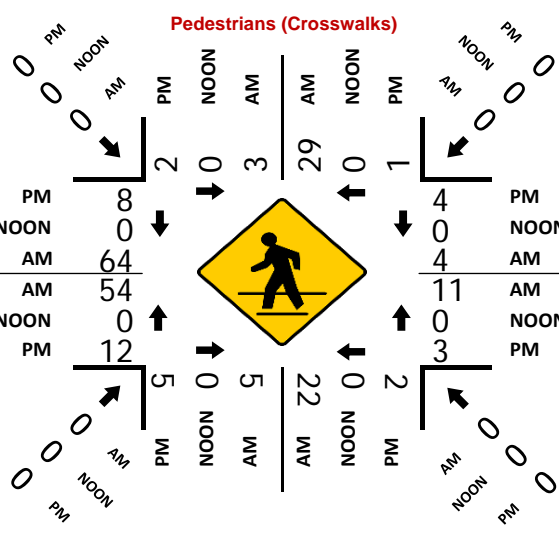
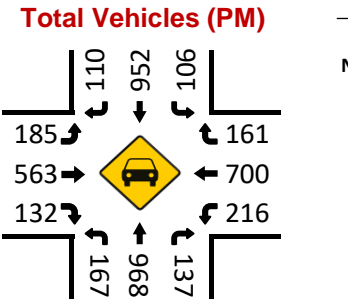
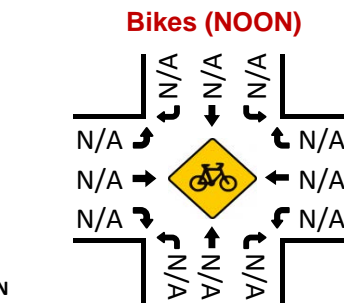
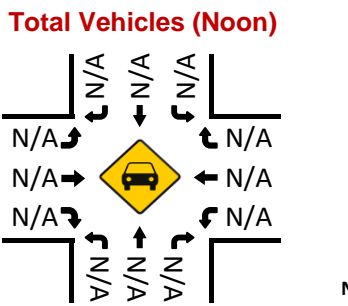
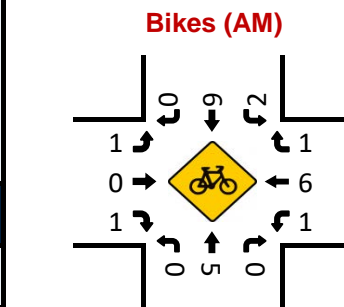
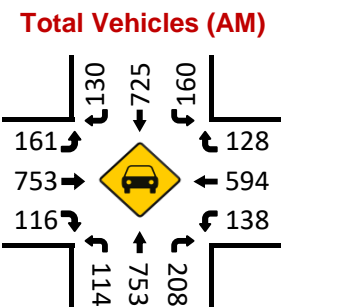

# Hawthorne Blvd & Del Amo Blvd

## Peak Hour Turning Movement Count

ID: 20-05014-024  
City: Torrance

Day: Tuesday  
Date: 01/14/2020

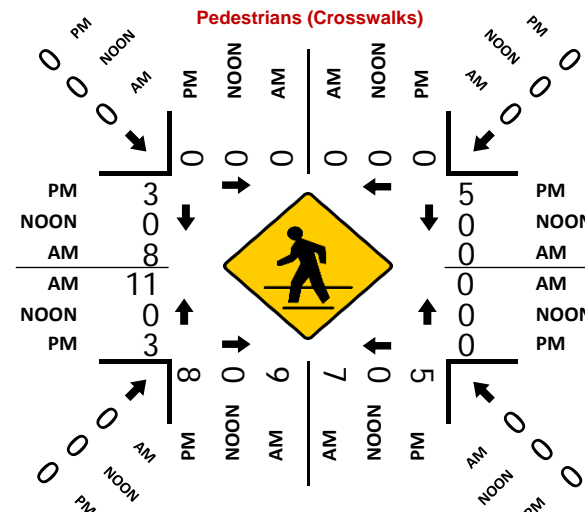
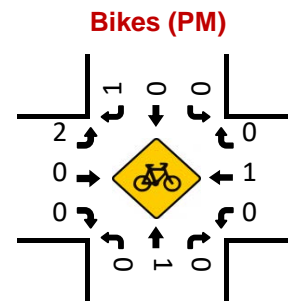
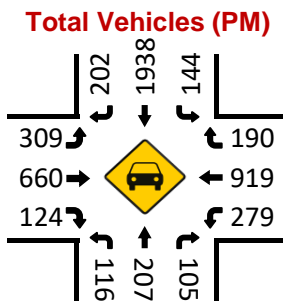
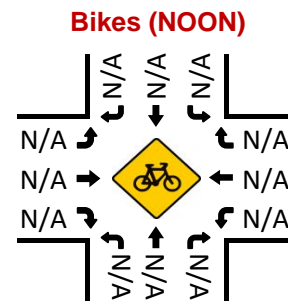
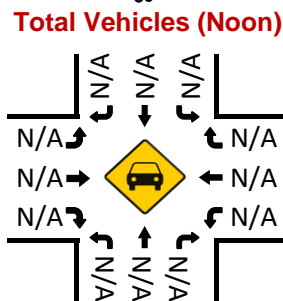
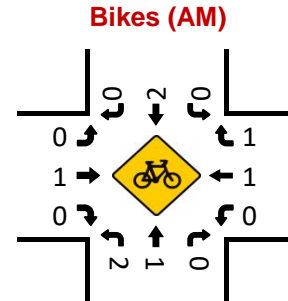
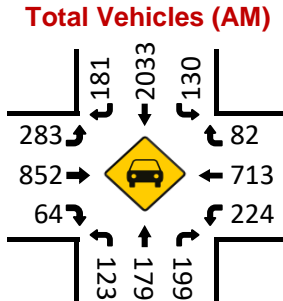
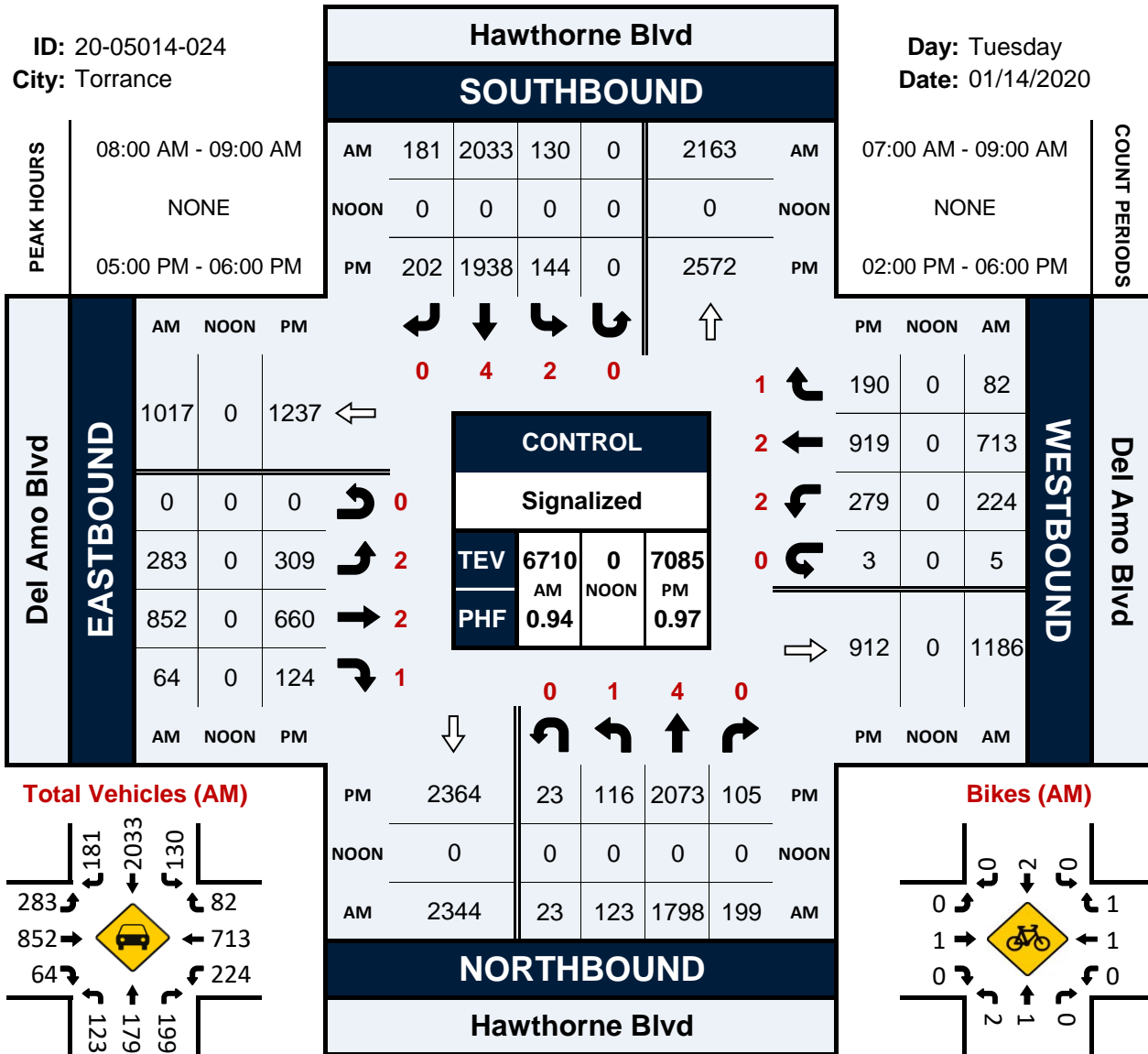

# Prospect Ave & Torrance Blvd

## Peak Hour Turning Movement Count

ID: 20-05014-025  
City: Redondo Beach

Day: Tuesday  
Date: 01/14/2020

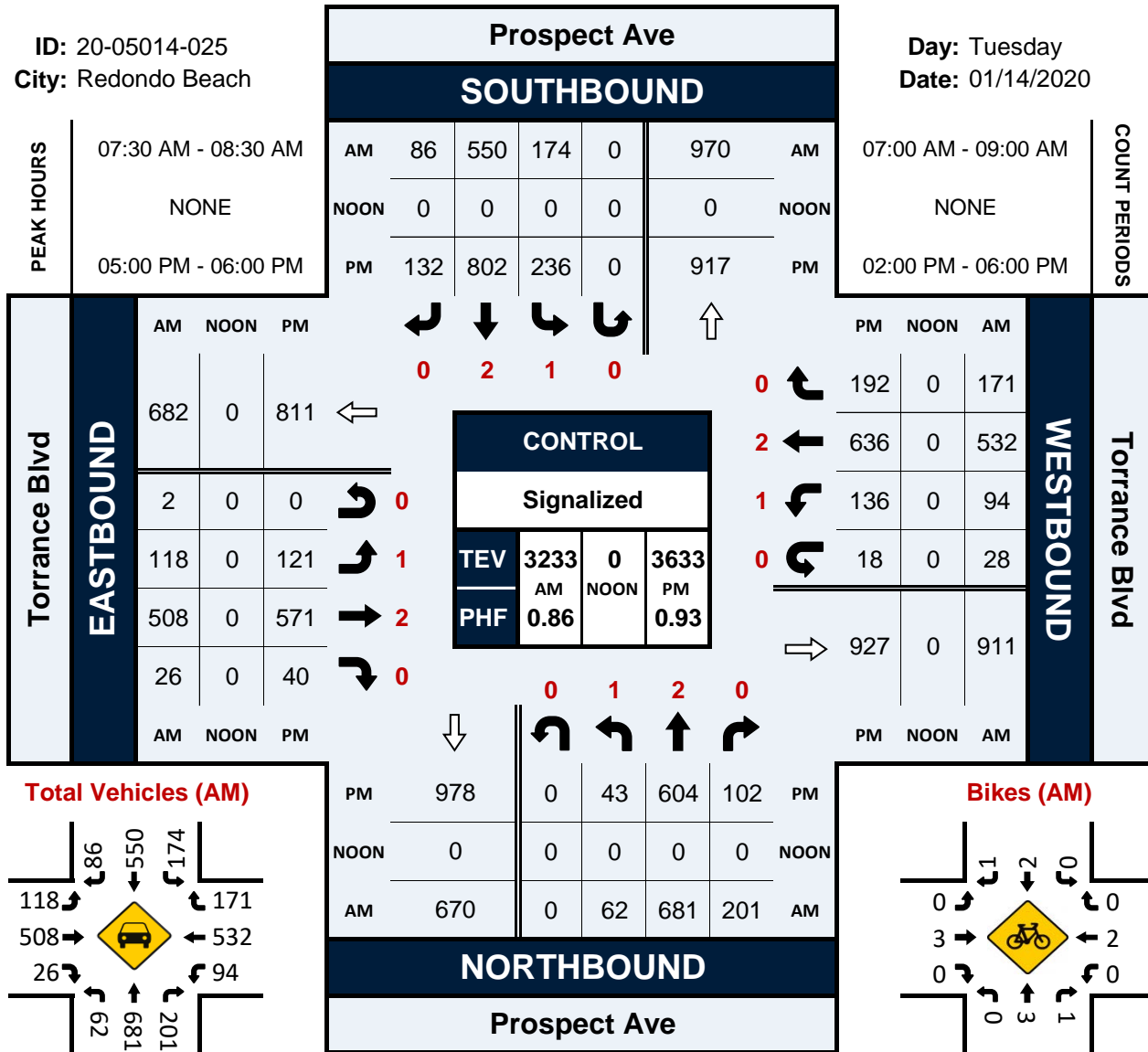

Total Vehicles (AM)

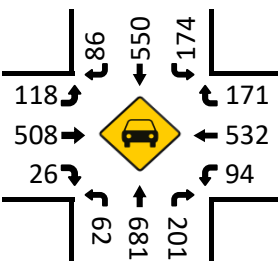

Bikes (AM)

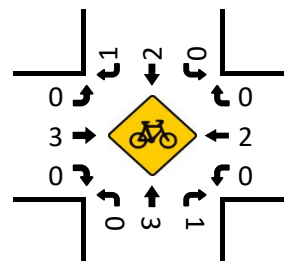

Total Vehicles (Noon)

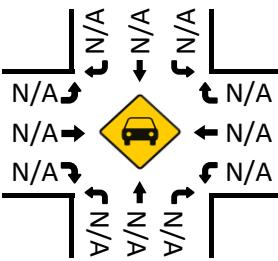

Bikes (NOON)

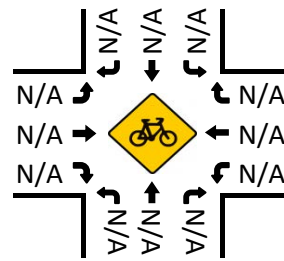

Total Vehicles (PM)

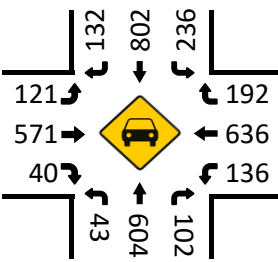

Bikes (PM)

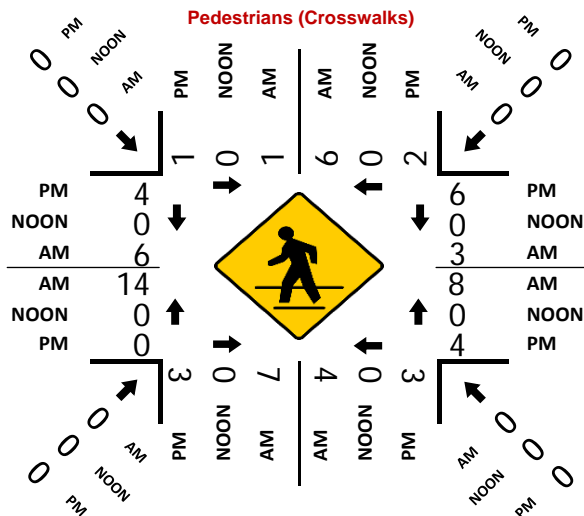
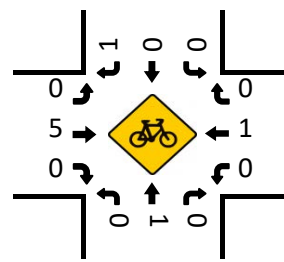

# Appendix F – Level of Service Worksheets



# Existing (2020) Conditions

**Project Title:** BCHD-HLC  
**Intersection:** 1 - Prospect Av & Anita St  
**Description:** Existing (2020)

Thru Lane: 1600 vph  
 Left Lane: 1600 vph  
 Double Lt Penalty: 10 %  
 ITS: 0 %

N-S Split Phase : N  
 E-W Split Phase : N  
 Lost Time (% of cycle) : 10  
 V/C Round Off (decs.) : 3

OLA Movements :  
 FF Movements:

**Date/Time:** AM PEAK HOUR

APPROACH	MVMT	LANES	VOLUME	CAPACITY	V/C	ICU ANALYSIS	
Southbound	RT	0.00	32	0	0.000	N-S(1):	0.289 *
	TH	2.00	345	3,200	0.118	N-S(2):	0.274
	LT	1.00	60	1,600	0.038 *	E-W(1):	0.243
Westbound	RT	0.00	71	0	0.000	E-W(2):	0.263 *
	TH	2.00	719	3,200	0.247 *	V/C:	0.552
	LT	1.00	156	1,600	0.098	Lost Time:	0.100
Northbound	RT	1.00	199	1,600	0.076	ITS:	0.000
	TH	1.00	401	1,600	0.251 *	ICU:	0.652
	LT	1.00	250	1,600	0.156	LOS:	B
Eastbound	RT	0.00	81	0	0.000		
	TH	2.00	384	3,200	0.145		
	LT	1.00	26	1,600	0.016 *		

**Date/Time:** PM PEAK HOUR

APPROACH	MVMT	LANES	VOLUME	CAPACITY	V/C	ICU ANALYSIS	
Southbound	RT	0.00	38	0	0.000	N-S(1):	0.250 *
	TH	2.00	536	3,200	0.179 *	N-S(2):	0.250 *
	LT	1.00	70	1,600	0.044 *	E-W(1):	0.295 *
Westbound	RT	0.00	81	0	0.000	E-W(2):	0.236
	TH	2.00	600	3,200	0.213	V/C:	0.545
	LT	1.00	125	1,600	0.078 *	Lost Time:	0.100
Northbound	RT	1.00	90	1,600	0.017	ITS:	0.000
	TH	1.00	329	1,600	0.206 *	ICU:	0.645
	LT	1.00	113	1,600	0.071 *	LOS:	B
Eastbound	RT	0.00	117	0	0.000		
	TH	2.00	577	3,200	0.217 *		
	LT	1.00	37	1,600	0.023		

\* - Denotes critical movement

**Project Title:** BCHD-HLC  
**Intersection:** 2 - Harkness Ln & Anita St  
**Description:** Existing (2020)

Thru Lane: 1600 vph  
 Left Lane: 1600 vph  
 Double Lt Penalty: 10 %  
 ITS: 0 %

N-S Split Phase : N  
 E-W Split Phase : N  
 Lost Time (% of cycle) : 10  
 V/C Round Off (decs.) : 3

OLA Movements :  
 FF Movements:

**Date/Time:** AM PEAK HOUR

APPROACH	MVMT	LANES	VOLUME	CAPACITY	V/C	ICU ANALYSIS	
Southbound	RT	0.00	66	0	0.000	N-S(1):	0.126
	TH	1.00	113	1,600	0.132 *	N-S(2):	0.238 *
	LT	0.00	32	1,600	0.020	E-W(1):	0.225
Westbound	RT	0.00	21	0	0.000	E-W(2):	0.299 *
	TH	2.00	830	3,200	0.266 *	V/C:	0.537
	LT	1.00	111	1,600	0.069	Lost Time:	0.100
Northbound	RT	1.00	26	1,600	0.000	ITS:	0.000
	TH	0.78	132	1,250	0.106	ICU:	0.637
	LT	0.22	37	350	0.106 *	LOS:	B
Eastbound	RT	1.00	20	1,600	0.000		
	TH	2.00	498	3,200	0.156		
	LT	1.00	52	1,600	0.033 *		

**Date/Time:** PM PEAK HOUR

APPROACH	MVMT	LANES	VOLUME	CAPACITY	V/C	ICU ANALYSIS	
Southbound	RT	0.00	47	0	0.000	N-S(1):	0.061
	TH	1.00	93	1,600	0.102 *	N-S(2):	0.149 *
	LT	0.00	23	1,600	0.014	E-W(1):	0.226
Westbound	RT	0.00	9	0	0.000	E-W(2):	0.241 *
	TH	2.00	670	3,200	0.212 *	V/C:	0.390
	LT	1.00	33	1,600	0.021	Lost Time:	0.100
Northbound	RT	1.00	5	1,600	0.000	ITS:	0.000
	TH	0.84	63	1,344	0.047	ICU:	0.490
	LT	0.16	12	256	0.047 *	LOS:	A
Eastbound	RT	1.00	42	1,600	0.003		
	TH	2.00	657	3,200	0.205		
	LT	1.00	47	1,600	0.029 *		

\* - Denotes critical movement

**Project Title:** BCHD-HLC  
**Intersection:** 4 - Beryl St/Blossom Ln & 190th St  
**Description:** Existing (2020)

Thru Lane: 1600 vph  
 Left Lane: 1600 vph  
 Double Lt Penalty: 10 %  
 ITS: 0 %

N-S Split Phase : N  
 E-W Split Phase : N  
 Lost Time (% of cycle) : 10  
 V/C Round Off (decs.) : 3

OLA Movements :  
 FF Movements:

**Date/Time:** AM PEAK HOUR

APPROACH	MVMT	LANES	VOLUME	CAPACITY	V/C	ICU ANALYSIS
Southbound	RT	1.00	22	1,600	0.008	N-S(1): 0.199 *
	TH	0.45	31	719	0.043	N-S(2): 0.048
	LT	0.55	38	881	0.043 *	E-W(1): 0.420 *
Westbound	RT	0.00	39	0	0.000	E-W(2): 0.257
	TH	2.00	748	3,200	0.246	V/C: 0.619
	LT	1.00	350	1,600	0.219 *	Lost Time: 0.100
Northbound	RT	1.00	425	1,600	0.156 *	ITS: 0.000
	TH	1.00	94	1,600	0.059	ICU: 0.719
	LT	1.00	8	1,600	0.005	LOS: C
Eastbound	RT	1.00	9	1,600	0.003	
	TH	2.00	644	3,200	0.201 *	
	LT	1.00	18	1,600	0.011	

**Date/Time:** PM PEAK HOUR

APPROACH	MVMT	LANES	VOLUME	CAPACITY	V/C	ICU ANALYSIS
Southbound	RT	1.00	16	1,600	0.006	N-S(1): 0.209 *
	TH	0.68	44	1,083	0.041	N-S(2): 0.044
	LT	0.32	21	517	0.041 *	E-W(1): 0.466 *
Westbound	RT	0.00	40	0	0.000	E-W(2): 0.254
	TH	2.00	747	3,200	0.246	V/C: 0.675
	LT	1.00	378	1,600	0.236 *	Lost Time: 0.100
Northbound	RT	1.00	457	1,600	0.168 *	ITS: 0.000
	TH	1.00	93	1,600	0.058	ICU: 0.775
	LT	1.00	4	1,600	0.003	LOS: C
Eastbound	RT	1.00	12	1,600	0.006	
	TH	2.00	736	3,200	0.230 *	
	LT	1.00	12	1,600	0.008	

\* - Denotes critical movement

**Project Title:** BCHD-HLC  
**Intersection:** 5 - Entradero Av/Meyer Ln & 190th St  
**Description:** Existing (2020)

Thru Lane: 1600 vph  
 Left Lane: 1600 vph  
 Double Lt Penalty: 10 %  
 ITS: 0 %

N-S Split Phase : N  
 E-W Split Phase : N  
 Lost Time (% of cycle) : 10  
 V/C Round Off (decs.) : 3

OLA Movements :  
 FF Movements:

**Date/Time:** AM PEAK HOUR

APPROACH	MVMT	LANES	VOLUME	CAPACITY	V/C	ICU ANALYSIS	
Southbound	RT	0.00	28	0	0.000	N-S(1):	0.242 *
	TH	1.00	78	1,600	0.132	N-S(2):	0.176
	LT	0.00	105	1,600	0.066 *	E-W(1):	0.428 *
Westbound	RT	1.00	100	1,600	0.030	E-W(2):	0.396
	TH	2.00	1,210	3,200	0.378	V/C:	0.670
	LT	1.00	94	1,600	0.059 *	Lost Time:	0.100
Northbound	RT	0.00	106	0	0.000	ITS:	0.000
	TH	1.00	106	1,600	0.176 *	ICU:	0.770
	LT	0.00	70	1,600	0.044	LOS:	C
Eastbound	RT	1.00	46	1,600	0.007		
	TH	2.00	1,180	3,200	0.369 *		
	LT	1.00	28	1,600	0.018		

**Date/Time:** PM PEAK HOUR

APPROACH	MVMT	LANES	VOLUME	CAPACITY	V/C	ICU ANALYSIS	
Southbound	RT	0.00	31	0	0.000	N-S(1):	0.169 *
	TH	1.00	67	1,600	0.114	N-S(2):	0.140
	LT	0.00	84	1,600	0.053 *	E-W(1):	0.447 *
Westbound	RT	1.00	102	1,600	0.038	E-W(2):	0.432
	TH	2.00	1,287	3,200	0.402	V/C:	0.616
	LT	1.00	78	1,600	0.049 *	Lost Time:	0.100
Northbound	RT	0.00	88	0	0.000	ITS:	0.000
	TH	1.00	57	1,600	0.116 *	ICU:	0.716
	LT	0.00	41	1,600	0.026	LOS:	C
Eastbound	RT	1.00	83	1,600	0.039		
	TH	2.00	1,272	3,200	0.398 *		
	LT	1.00	48	1,600	0.030		

\* - Denotes critical movement

**Project Title: BCHD-HLC**  
**Intersection: 6 - Anza Av & 190th St**  
**Description: Existing (2020)**

Thru Lane: 1600 vph  
 Left Lane: 1600 vph  
 Double Lt Penalty: 10 %  
 ITS: 0 %

N-S Split Phase : N  
 E-W Split Phase : N  
 Lost Time (% of cycle) : 10  
 V/C Round Off (decs.) : 3

OLA Movements :  
 FF Movements:

**Date/Time: AM PEAK HOUR**

APPROACH	MVMT	LANES	VOLUME	CAPACITY	V/C	ICU ANALYSIS
Southbound	RT	0.00	0	0	0.000	N-S(1): 0.239 *
	TH	0.00	0	0	0.000	N-S(2): 0.188
	LT	0.00	0	0	0.000 *	E-W(1): 0.452 *
Westbound	RT	0.00	0	0	0.000	E-W(2): 0.277
	TH	2.00	886	3,200	0.277	V/C: 0.691
	LT	2.00	455	2,880	0.158 *	Lost Time: 0.100
Northbound	RT	1.00	509	1,600	0.239 *	ITS: 0.000
	TH	0.00	0	0	0.000	
	LT	2.00	542	2,880	0.188	
Eastbound	RT	1.00	344	1,600	0.215	ICU: 0.791
	TH	2.00	942	3,200	0.294 *	
	LT	0.00	0	0	0.000	LOS: C

**Date/Time: PM PEAK HOUR**

APPROACH	MVMT	LANES	VOLUME	CAPACITY	V/C	ICU ANALYSIS
Southbound	RT	0.00	0	0	0.000	N-S(1): 0.222 *
	TH	0.00	0	0	0.000	N-S(2): 0.204
	LT	0.00	0	0	0.000 *	E-W(1): 0.511 *
Westbound	RT	0.00	0	0	0.000	E-W(2): 0.286
	TH	2.00	914	3,200	0.286	V/C: 0.733
	LT	2.00	565	2,880	0.196 *	Lost Time: 0.100
Northbound	RT	1.00	512	1,600	0.222 *	ITS: 0.000
	TH	0.00	0	0	0.000	
	LT	2.00	587	2,880	0.204	
Eastbound	RT	1.00	489	1,600	0.306	ICU: 0.833
	TH	2.00	1,008	3,200	0.315 *	
	LT	0.00	0	0	0.000	LOS: D

\* - Denotes critical movement

**Project Title:** BCHD-HLC  
**Intersection:** 7 - Inglewood Ave & 190th St  
**Description:** Existing (2020)

Thru Lane: 1600 vph  
 Left Lane: 1600 vph  
 Double Lt Penalty: 10 %  
 ITS: 0 %

N-S Split Phase : N  
 E-W Split Phase : N  
 Lost Time (% of cycle) : 10  
 V/C Round Off (decs.) : 3

OLA Movements :  
 FF Movements:

**Date/Time:** AM PEAK HOUR

APPROACH	MVMT	LANES	VOLUME	CAPACITY	V/C	ICU ANALYSIS	
Southbound	RT	1.00	541	1,600	0.240 *	N-S(1):	0.244
	TH	0.11	31	175	0.178	N-S(2):	0.249 *
	LT	0.89	253	1,425	0.178	E-W(1):	0.287
Westbound	RT	0.00	170	0	0.000	E-W(2):	0.402 *
	TH	3.00	818	4,800	0.206 *	V/C:	0.651
	LT	1.00	19	1,600	0.012	Lost Time:	0.100
Northbound	RT	0.00	27	0	0.000	ITS:	0.000
	TH	1.00	64	1,600	0.066	ICU:	0.751
	LT	0.00	15	1,600	0.009 *	LOS:	C
Eastbound	RT	0.00	5	0	0.000		
	TH	2.00	875	3,200	0.275		
	LT	2.00	565	2,880	0.196 *		

**Date/Time:** PM PEAK HOUR

APPROACH	MVMT	LANES	VOLUME	CAPACITY	V/C	ICU ANALYSIS	
Southbound	RT	1.00	561	1,600	0.243	N-S(1):	0.297 *
	TH	0.21	69	338	0.204	N-S(2):	0.263
	LT	0.79	258	1,262	0.204 *	E-W(1):	0.311
Westbound	RT	0.00	206	0	0.000	E-W(2):	0.459 *
	TH	3.00	962	4,800	0.243 *	V/C:	0.756
	LT	1.00	55	1,600	0.034	Lost Time:	0.100
Northbound	RT	0.00	15	0	0.000	ITS:	0.000
	TH	1.00	102	1,600	0.093 *	ICU:	0.856
	LT	0.00	32	1,600	0.020	LOS:	D
Eastbound	RT	0.00	14	0	0.000		
	TH	2.00	873	3,200	0.277		
	LT	2.00	621	2,880	0.216 *		

\* - Denotes critical movement

**Project Title:** BCHD-HLC  
**Intersection:** 8 - Hawthorne BI & 190th St  
**Description:** Existing (2020)

Thru Lane: 1600 vph  
 Left Lane: 1600 vph  
 Double Lt Penalty: 10 %  
 ITS: 0 %

N-S Split Phase : N  
 E-W Split Phase : N  
 Lost Time (% of cycle) : 10  
 V/C Round Off (decs.) : 3

OLA Movements :  
 FF Movements:

**Date/Time:** AM PEAK HOUR

APPROACH	MVMT	LANES	VOLUME	CAPACITY	V/C	ICU ANALYSIS	
Southbound	RT	1.00	171	1,600	0.077	N-S(1):	0.313
	TH	4.00	2,007	6,400	0.314 *	N-S(2):	0.371 *
	LT	2.00	86	2,880	0.030	E-W(1):	0.348 *
Westbound	RT	1.00	153	1,600	0.081	E-W(2):	0.279
	TH	2.00	703	3,200	0.220	V/C:	0.719
	LT	2.00	260	2,880	0.090 *	Lost Time:	0.100
Northbound	RT	1.00	197	1,600	0.078	ITS:	0.000
	TH	4.00	1,808	6,400	0.283	ICU:	0.819
	LT	2.00	163	2,880	0.057 *	LOS:	D
Eastbound	RT	1.00	234	1,600	0.118		
	TH	2.00	827	3,200	0.258 *		
	LT	2.00	170	2,880	0.059		

**Date/Time:** PM PEAK HOUR

APPROACH	MVMT	LANES	VOLUME	CAPACITY	V/C	ICU ANALYSIS	
Southbound	RT	1.00	186	1,600	0.092	N-S(1):	0.377 *
	TH	4.00	1,639	6,400	0.256	N-S(2):	0.357
	LT	2.00	164	2,880	0.057 *	E-W(1):	0.336 *
Westbound	RT	1.00	156	1,600	0.069	E-W(2):	0.314
	TH	2.00	852	3,200	0.266	V/C:	0.713
	LT	2.00	304	2,880	0.106 *	Lost Time:	0.100
Northbound	RT	1.00	390	1,600	0.191	ITS:	0.000
	TH	4.00	2,049	6,400	0.320 *	ICU:	0.813
	LT	2.00	290	2,880	0.101	LOS:	D
Eastbound	RT	1.00	301	1,600	0.138		
	TH	2.00	736	3,200	0.230 *		
	LT	2.00	138	2,880	0.048		

\* - Denotes critical movement



**Project Title:** BCHD-HLC  
**Intersection:** 9 - Prospect Av & Beryl St  
**Description:** Existing (2020)

Thru Lane: 1600 vph  
 Left Lane: 1600 vph  
 Double Lt Penalty: 10 %  
 ITS: 0 %

N-S Split Phase : N  
 E-W Split Phase : N  
 Lost Time (% of cycle) : 10  
 V/C Round Off (decs.) : 3

OLA Movements :  
 FF Movements:

**Date/Time:** AM PEAK HOUR

APPROACH	MVMT	LANES	VOLUME	CAPACITY	V/C	ICU ANALYSIS
Southbound	RT	0.00	111	0	0.000	N-S(1): 0.322 *
	TH	2.00	474	3,200	0.183	N-S(2): 0.221
	LT	1.00	15	1,600	0.009 *	E-W(1): 0.376 *
Westbound	RT	1.00	16	1,600	0.005	E-W(2): 0.292
	TH	1.00	372	1,600	0.233	V/C: 0.698
	LT	1.00	371	1,600	0.232 *	Lost Time: 0.100
Northbound	RT	0.00	295	0	0.000	ITS: 0.000
	TH	2.00	708	3,200	0.313 *	ICU: 0.798
	LT	1.00	61	1,600	0.038	LOS: C
Eastbound	RT	0.00	53	0	0.000	
	TH	2.00	408	3,200	0.144 *	
	LT	1.00	95	1,600	0.059	

**Date/Time:** PM PEAK HOUR

APPROACH	MVMT	LANES	VOLUME	CAPACITY	V/C	ICU ANALYSIS
Southbound	RT	0.00	54	0	0.000	N-S(1): 0.262
	TH	2.00	680	3,200	0.229 *	N-S(2): 0.285 *
	LT	1.00	37	1,600	0.023	E-W(1): 0.301 *
Westbound	RT	1.00	30	1,600	0.007	E-W(2): 0.200
	TH	1.00	285	1,600	0.178	V/C: 0.586
	LT	1.00	289	1,600	0.181 *	Lost Time: 0.100
Northbound	RT	0.00	280	0	0.000	ITS: 0.000
	TH	2.00	485	3,200	0.239	ICU: 0.686
	LT	1.00	90	1,600	0.056 *	LOS: B
Eastbound	RT	0.00	44	0	0.000	
	TH	2.00	340	3,200	0.120 *	
	LT	1.00	35	1,600	0.022	

\* - Denotes critical movement

**Project Title:** BCHD-HLC  
**Intersection:** 13 - Prospect Av & Middle Campus Driveway  
**Description:** Existing (2020)

Thru Lane: 1600 vph  
 Left Lane: 1600 vph  
 Double Lt Penalty: 10 %  
 ITS: 0 %

N-S Split Phase : N  
 E-W Split Phase : N  
 Lost Time (% of cycle) : 10  
 V/C Round Off (decs.) : 3

OLA Movements :  
 FF Movements:

**Date/Time:** AM PEAK HOUR

APPROACH	MVMT	LANES	VOLUME	CAPACITY	V/C	ICU ANALYSIS	
Southbound	RT	0.20	0	320	0.000	N-S(1):	0.445
	TH	0.80	765	1,280	0.598 *	N-S(2):	0.598 *
	LT	1.00	138	1,600	0.086	E-W(1):	0.071 *
Westbound	RT	1.00	26	1,600	0.000	E-W(2):	0.000
	TH	0.00	0	0	0.000	V/C:	0.669
	LT	1.00	114	1,600	0.071 *	Lost Time:	0.100
Northbound	RT	0.00	92	0	0.000	ITS:	0.000
	TH	2.00	1,057	3,200	0.359	ICU:	0.769
	LT	1.00	0	1,600	0.000 *	LOS:	C
Eastbound	RT	0.00	0	0	0.000		
	TH	1.00	0	1,600	0.000 *		
	LT	0.00	0	0	0.000		

**Date/Time:** PM PEAK HOUR

APPROACH	MVMT	LANES	VOLUME	CAPACITY	V/C	ICU ANALYSIS	
Southbound	RT	0.00	0	0	0.000	N-S(1):	0.285
	TH	2.00	991	3,200	0.310 *	N-S(2):	0.311 *
	LT	1.00	61	1,600	0.038	E-W(1):	0.071 *
Westbound	RT	1.00	89	1,600	0.037	E-W(2):	0.037
	TH	0.00	0	0	0.000	V/C:	0.382
	LT	1.00	114	1,600	0.071 *	Lost Time:	0.100
Northbound	RT	0.00	31	0	0.000	ITS:	0.000
	TH	2.00	760	3,200	0.247	ICU:	0.482
	LT	1.00	2	1,600	0.001 *	LOS:	A
Eastbound	RT	0.00	0	0	0.000		
	TH	1.00	0	1,600	0.000 *		
	LT	0.00	0	0	0.000		

\* - Denotes critical movement

**Project Title:** BCHD-HLC  
**Intersection:** 15 - Prospect Av & Diamond St  
**Description:** Existing (2020)

Thru Lane: 1600 vph  
 Left Lane: 1600 vph  
 Double Lt Penalty: 10 %  
 ITS: 0 %

N-S Split Phase : N  
 E-W Split Phase : N  
 Lost Time (% of cycle) : 10  
 V/C Round Off (decs.) : 3

OLA Movements :  
 FF Movements:

**Date/Time:** AM PEAK HOUR

APPROACH	MVMT	LANES	VOLUME	CAPACITY	V/C	ICU ANALYSIS	
Southbound	RT	0.00	189	0	0.000	N-S(1):	0.346 *
	TH	2.00	606	3,200	0.248	N-S(2):	0.284
	LT	1.00	7	1,600	0.004 *	E-W(1):	0.063
Westbound	RT	1.00	3	1,600	0.000	E-W(2):	0.069 *
	TH	1.00	0	1,600	0.000 *	V/C:	0.415
	LT	1.00	1	1,600	0.001	Lost Time:	0.100
Northbound	RT	0.00	0	0	0.000	ITS:	0.000
	TH	2.00	1,093	3,200	0.342 *	ICU:	0.515
	LT	1.00	58	1,600	0.036	LOS:	A
Eastbound	RT	0.00	66	0	0.000		
	TH	0.66	0	1,061	0.062		
	LT	1.34	133	1,925	0.069 *		

**Date/Time:** PM PEAK HOUR

APPROACH	MVMT	LANES	VOLUME	CAPACITY	V/C	ICU ANALYSIS	
Southbound	RT	0.00	65	0	0.000	N-S(1):	0.238
	TH	2.00	1,027	3,200	0.341 *	N-S(2):	0.347 *
	LT	1.00	12	1,600	0.008	E-W(1):	0.024
Westbound	RT	1.00	2	1,600	0.001 *	E-W(2):	0.027 *
	TH	1.00	0	1,600	0.000	V/C:	0.374
	LT	1.00	0	1,600	0.000	Lost Time:	0.100
Northbound	RT	0.00	3	0	0.000	ITS:	0.000
	TH	2.00	732	3,200	0.230	ICU:	0.474
	LT	1.00	9	1,600	0.006 *	LOS:	A
Eastbound	RT	0.00	22	0	0.000		
	TH	0.58	0	926	0.024		
	LT	1.42	54	2,046	0.026 *		

\* - Denotes critical movement

**Project Title:** BCHD-HLC  
**Intersection:** 16 - Hallison St & Anza Av  
**Description:** Existing (2020)

Thru Lane: 1600 vph  
 Left Lane: 1600 vph  
 Double Lt Penalty: 10 %  
 ITS: 0 %

N-S Split Phase : N  
 E-W Split Phase : N  
 Lost Time (% of cycle) : 10  
 V/C Round Off (decs.) : 3

OLA Movements :  
 FF Movements:

**Date/Time:** AM PEAK HOUR

APPROACH	MVMT	LANES	VOLUME	CAPACITY	V/C	ICU ANALYSIS
Southbound	RT	0.00	22	0	0.000	N-S(1): 0.338 *
	TH	2.00	912	3,200	0.292	N-S(2): 0.308
	LT	1.00	28	1,600	0.018 *	E-W(1): 0.136
Westbound	RT	0.00	45	0	0.000	E-W(2): 0.138 *
	TH	1.00	57	1,600	0.099 *	V/C: 0.476
	LT	0.00	57	1,600	0.036	Lost Time: 0.100
Northbound	RT	0.00	24	0	0.000	ITS: 0.000
	TH	2.00	1,000	3,200	0.320 *	ICU: 0.576
	LT	1.00	25	1,600	0.016	LOS: A
Eastbound	RT	0.00	58	0	0.000	
	TH	1.00	40	1,600	0.100	
	LT	0.00	62	1,600	0.039 *	

**Date/Time:** PM PEAK HOUR

APPROACH	MVMT	LANES	VOLUME	CAPACITY	V/C	ICU ANALYSIS
Southbound	RT	0.00	35	0	0.000	N-S(1): 0.397 *
	TH	2.00	1,120	3,200	0.361	N-S(2): 0.384
	LT	1.00	28	1,600	0.018 *	E-W(1): 0.047
Westbound	RT	0.00	35	0	0.000	E-W(2): 0.070 *
	TH	1.00	29	1,600	0.059 *	V/C: 0.467
	LT	0.00	31	1,600	0.019	Lost Time: 0.100
Northbound	RT	0.00	29	0	0.000	ITS: 0.000
	TH	2.00	1,185	3,200	0.379 *	ICU: 0.567
	LT	1.00	37	1,600	0.023	LOS: A
Eastbound	RT	0.00	12	0	0.000	
	TH	1.00	15	1,600	0.028	
	LT	0.00	18	1,600	0.011 *	

\* - Denotes critical movement

**Project Title:** BCHD-HLC  
**Intersection:** 17 - Prospect Av & Del Amo Bl  
**Description:** Existing (2020)

Thru Lane: 1600 vph  
 Left Lane: 1600 vph  
 Double Lt Penalty: 10 %  
 ITS: 0 %

N-S Split Phase : N  
 E-W Split Phase : N  
 Lost Time (% of cycle) : 10  
 V/C Round Off (decs.) : 3

OLA Movements :  
 FF Movements:

**Date/Time:** AM PEAK HOUR

APPROACH	MVMT	LANES	VOLUME	CAPACITY	V/C	ICU ANALYSIS	
Southbound	RT	0.00	37	0	0.000	N-S(1):	0.413 *
	TH	2.00	558	3,200	0.186	N-S(2):	0.271
	LT	1.00	67	1,600	0.042 *	E-W(1):	0.300 *
Westbound	RT	1.00	264	1,600	0.144	E-W(2):	0.180
	TH	1.00	254	1,600	0.159	V/C:	0.713
	LT	1.00	265	1,600	0.166 *	Lost Time:	0.100
Northbound	RT	0.00	342	0	0.000	ITS:	0.000
	TH	2.00	845	3,200	0.371 *	ICU:	0.813
	LT	1.00	136	1,600	0.085	LOS:	D
Eastbound	RT	1.00	144	1,600	0.048		
	TH	1.00	215	1,600	0.134 *		
	LT	1.00	34	1,600	0.021		

**Date/Time:** PM PEAK HOUR

APPROACH	MVMT	LANES	VOLUME	CAPACITY	V/C	ICU ANALYSIS	
Southbound	RT	0.00	5	0	0.000	N-S(1):	0.373 *
	TH	2.00	861	3,200	0.271	N-S(2):	0.329
	LT	1.00	184	1,600	0.115 *	E-W(1):	0.301 *
Westbound	RT	1.00	203	1,600	0.069	E-W(2):	0.121
	TH	1.00	178	1,600	0.111	V/C:	0.674
	LT	1.00	316	1,600	0.198 *	Lost Time:	0.100
Northbound	RT	0.00	287	0	0.000	ITS:	0.000
	TH	2.00	537	3,200	0.258 *	ICU:	0.774
	LT	1.00	93	1,600	0.058	LOS:	C
Eastbound	RT	1.00	134	1,600	0.055		
	TH	1.00	164	1,600	0.103 *		
	LT	1.00	16	1,600	0.010		

\* - Denotes critical movement

**Project Title: BCHD-HLC**  
**Intersection: 19 - Wayne Av & Del Amo Bl**  
**Description: Existing (2020)**

Thru Lane: 1600 vph  
 Left Lane: 1600 vph  
 Double Lt Penalty: 10 %  
 ITS: 0 %

N-S Split Phase : N  
 E-W Split Phase : N  
 Lost Time (% of cycle) : 10  
 V/C Round Off (decs.) : 3

OLA Movements :  
 FF Movements:

**Date/Time: AM PEAK HOUR**

APPROACH	MVMT	LANES	VOLUME	CAPACITY	V/C	ICU ANALYSIS
Southbound	RT	0.00	32	0	0.000	N-S(1): 0.109 *
	TH	1.00	28	1,600	0.059	N-S(2): 0.088
	LT	0.00	34	1,600	0.021 *	E-W(1): 0.214
Westbound	RT	0.00	14	0	0.000	E-W(2): 0.237 *
	TH	2.00	726	3,200	0.231 *	V/C: 0.346
	LT	1.00	19	1,600	0.012	Lost Time: 0.100
Northbound	RT	0.00	75	0	0.000	ITS: 0.000
	TH	1.00	18	1,600	0.088 *	ICU: 0.446
	LT	0.00	47	1,600	0.029	LOS: A
Eastbound	RT	0.00	6	0	0.000	
	TH	2.00	639	3,200	0.202	
	LT	1.00	10	1,600	0.006 *	

**Date/Time: PM PEAK HOUR**

APPROACH	MVMT	LANES	VOLUME	CAPACITY	V/C	ICU ANALYSIS
Southbound	RT	0.00	7	0	0.000	N-S(1): 0.046 *
	TH	1.00	8	1,600	0.026	N-S(2): 0.030
	LT	0.00	26	1,600	0.016 *	E-W(1): 0.239
Westbound	RT	0.00	22	0	0.000	E-W(2): 0.246 *
	TH	2.00	745	3,200	0.240 *	V/C: 0.292
	LT	1.00	30	1,600	0.019	Lost Time: 0.100
Northbound	RT	0.00	36	0	0.000	ITS: 0.000
	TH	1.00	5	1,600	0.030 *	ICU: 0.392
	LT	0.00	7	1,600	0.004	LOS: A
Eastbound	RT	0.00	7	0	0.000	
	TH	2.00	697	3,200	0.220	
	LT	1.00	10	1,600	0.006 *	

\* - Denotes critical movement

**Project Title:** BCHD-HLC  
**Intersection:** 20 - Henrietta St & Del Amo Bl  
**Description:** Existing (2020)

Thru Lane: 1600 vph  
 Left Lane: 1600 vph  
 Double Lt Penalty: 10 %  
 ITS: 0 %

N-S Split Phase : N  
 E-W Split Phase : N  
 Lost Time (% of cycle) : 10  
 V/C Round Off (decs.) : 3

OLA Movements :  
 FF Movements:

**Date/Time:** AM PEAK HOUR

APPROACH	MVMT	LANES	VOLUME	CAPACITY	V/C	ICU ANALYSIS	
Southbound	RT	0.00	0	0	0.000	N-S(1):	0.045
	TH	0.00	0	0	0.000 *	N-S(2):	0.075 *
	LT	0.00	0	0	0.000	E-W(1):	0.333 *
Westbound	RT	0.00	0	0	0.000	E-W(2):	0.204
	TH	2.00	653	3,200	0.204	V/C:	0.408
	LT	1.00	159	1,600	0.099 *	Lost Time:	0.100
Northbound	RT	1.00	151	1,600	0.045	ITS:	0.000
	TH	0.00	0	0	0.000	ICU:	0.508
	LT	1.00	120	1,600	0.075 *	LOS:	A
Eastbound	RT	0.00	42	0	0.000		
	TH	2.00	707	3,200	0.234 *		
	LT	0.00	0	0	0.000		

**Date/Time:** PM PEAK HOUR

APPROACH	MVMT	LANES	VOLUME	CAPACITY	V/C	ICU ANALYSIS	
Southbound	RT	0.00	0	0	0.000	N-S(1):	0.033
	TH	0.00	0	0	0.000 *	N-S(2):	0.045 *
	LT	0.00	0	0	0.000	E-W(1):	0.323 *
Westbound	RT	0.00	0	0	0.000	E-W(2):	0.226
	TH	2.00	722	3,200	0.226	V/C:	0.368
	LT	1.00	141	1,600	0.088 *	Lost Time:	0.100
Northbound	RT	1.00	124	1,600	0.033	ITS:	0.000
	TH	0.00	0	0	0.000	ICU:	0.468
	LT	1.00	72	1,600	0.045 *	LOS:	A
Eastbound	RT	0.00	74	0	0.000		
	TH	2.00	677	3,200	0.235 *		
	LT	0.00	0	0	0.000		

\* - Denotes critical movement

**Project Title:** BCHD-HLC  
**Intersection:** 21 - Entradero Av & Del Amo Bl  
**Description:** Existing (2020)

Thru Lane: 1600 vph  
 Left Lane: 1600 vph  
 Double Lt Penalty: 10 %  
 ITS: 0 %

N-S Split Phase : N  
 E-W Split Phase : N  
 Lost Time (% of cycle) : 10  
 V/C Round Off (decs.) : 3

OLA Movements :  
 FF Movements:

**Date/Time:** AM PEAK HOUR

APPROACH	MVMT	LANES	VOLUME	CAPACITY	V/C	ICU ANALYSIS
Southbound	RT	0.54	210	859	0.201	N-S(1): 0.244 *
	TH	0.00	0	0	0.000	N-S(2): 0.201
	LT	0.46	181	741	0.244 *	E-W(1): 0.215
Westbound	RT	0.00	174	0	0.000	E-W(2): 0.341 *
	TH	2.00	638	3,200	0.254 *	V/C: 0.585
	LT	0.00	0	0	0.000	Lost Time: 0.100
Northbound	RT	0.00	0	0	0.000	ITS: 0.000
	TH	0.00	0	0	0.000 *	
	LT	0.00	0	0	0.000	
Eastbound	RT	0.00	0	0	0.000	ICU: 0.685
	TH	2.00	688	3,200	0.215	
	LT	1.00	139	1,600	0.087 *	LOS: B

**Date/Time:** PM PEAK HOUR

APPROACH	MVMT	LANES	VOLUME	CAPACITY	V/C	ICU ANALYSIS
Southbound	RT	0.48	85	773	0.089	N-S(1): 0.110 *
	TH	0.00	0	0	0.000	N-S(2): 0.089
	LT	0.52	91	827	0.110 *	E-W(1): 0.228
Westbound	RT	0.00	89	0	0.000	E-W(2): 0.316 *
	TH	2.00	792	3,200	0.275 *	V/C: 0.426
	LT	0.00	0	0	0.000	Lost Time: 0.100
Northbound	RT	0.00	0	0	0.000	ITS: 0.000
	TH	0.00	0	0	0.000 *	
	LT	0.00	0	0	0.000	
Eastbound	RT	0.00	0	0	0.000	ICU: 0.526
	TH	2.00	731	3,200	0.228	
	LT	1.00	66	1,600	0.041 *	LOS: A

\* - Denotes critical movement



**Project Title:** BCHD-HLC  
**Intersection:** 22 - Victor St & Del Amo BI  
**Description:** Existing (2020)

Thru Lane: 1600 vph  
 Left Lane: 1600 vph  
 Double Lt Penalty: 10 %  
 ITS: 0 %

N-S Split Phase : N  
 E-W Split Phase : N  
 Lost Time (% of cycle) : 10  
 V/C Round Off (decs.) : 3

OLA Movements :  
 FF Movements:

**Date/Time:** AM PEAK HOUR

APPROACH	MVMT	LANES	VOLUME	CAPACITY	V/C	ICU ANALYSIS	
Southbound	RT	0.00	0	0	0.000	N-S(1):	0.097 *
	TH	0.00	0	0	0.000	N-S(2):	0.073
	LT	0.00	0	0	0.000 *	E-W(1):	0.346 *
Westbound	RT	0.00	0	0	0.000	E-W(2):	0.166
	TH	2.00	532	3,200	0.166	V/C:	0.443
	LT	1.00	129	1,600	0.081 *	Lost Time:	0.100
Northbound	RT	1.00	219	1,600	0.097 *	ITS:	0.000
	TH	0.00	0	0	0.000	ICU:	0.543
	LT	1.00	116	1,600	0.073	LOS:	A
Eastbound	RT	0.00	166	0	0.000		
	TH	2.00	682	3,200	0.265 *		
	LT	0.00	0	0	0.000		

**Date/Time:** PM PEAK HOUR

APPROACH	MVMT	LANES	VOLUME	CAPACITY	V/C	ICU ANALYSIS	
Southbound	RT	0.00	0	0	0.000	N-S(1):	0.035 *
	TH	0.00	0	0	0.000	N-S(2):	0.028
	LT	0.00	0	0	0.000 *	E-W(1):	0.298 *
Westbound	RT	0.00	0	0	0.000	E-W(2):	0.263
	TH	2.00	842	3,200	0.263	V/C:	0.333
	LT	1.00	67	1,600	0.042 *	Lost Time:	0.100
Northbound	RT	1.00	90	1,600	0.035 *	ITS:	0.000
	TH	0.00	0	0	0.000	ICU:	0.433
	LT	1.00	45	1,600	0.028	LOS:	A
Eastbound	RT	0.00	55	0	0.000		
	TH	2.00	764	3,200	0.256 *		
	LT	0.00	0	0	0.000		

\* - Denotes critical movement

**Project Title:** BCHD-HLC  
**Intersection:** 23 - Anza Av & Del Amo Bl  
**Description:** Existing (2020)

Thru Lane: 1600 vph  
 Left Lane: 1600 vph  
 Double Lt Penalty: 10 %  
 ITS: 0 %

N-S Split Phase : N  
 E-W Split Phase : N  
 Lost Time (% of cycle) : 10  
 V/C Round Off (decs.) : 3

OLA Movements :  
 FF Movements:

**Date/Time:** AM PEAK HOUR

APPROACH	MVMT	LANES	VOLUME	CAPACITY	V/C	ICU ANALYSIS	
Southbound	RT	0.00	130	0	0.000	N-S(1):	0.335
	TH	2.00	725	3,200	0.267 *	N-S(2):	0.338 *
	LT	1.00	160	1,600	0.100	E-W(1):	0.321
Westbound	RT	0.00	128	0	0.000	E-W(2):	0.327 *
	TH	2.00	594	3,200	0.226 *	V/C:	0.665
	LT	1.00	138	1,600	0.086	Lost Time:	0.100
Northbound	RT	1.00	208	1,600	0.087	ITS:	0.000
	TH	2.00	753	3,200	0.235	ICU:	0.765
	LT	1.00	114	1,600	0.071 *	LOS:	C
Eastbound	RT	1.00	116	1,600	0.037		
	TH	2.00	753	3,200	0.235		
	LT	1.00	161	1,600	0.101 *		

**Date/Time:** PM PEAK HOUR

APPROACH	MVMT	LANES	VOLUME	CAPACITY	V/C	ICU ANALYSIS	
Southbound	RT	0.00	110	0	0.000	N-S(1):	0.369
	TH	2.00	952	3,200	0.332 *	N-S(2):	0.436 *
	LT	1.00	106	1,600	0.066	E-W(1):	0.311
Westbound	RT	0.00	161	0	0.000	E-W(2):	0.385 *
	TH	2.00	700	3,200	0.269 *	V/C:	0.821
	LT	1.00	216	1,600	0.135	Lost Time:	0.100
Northbound	RT	1.00	137	1,600	0.018	ITS:	0.000
	TH	2.00	968	3,200	0.303	ICU:	0.921
	LT	1.00	167	1,600	0.104 *	LOS:	E
Eastbound	RT	1.00	132	1,600	0.030		
	TH	2.00	563	3,200	0.176		
	LT	1.00	185	1,600	0.116 *		

\* - Denotes critical movement

**Project Title:** BCHD-HLC  
**Intersection:** 24 - Hawthorne BI & Del Amo BI  
**Description:** Existing (2020)

Thru Lane: 1600 vph  
 Left Lane: 1600 vph  
 Double Lt Penalty: 10 %  
 ITS: 0 %

N-S Split Phase : N  
 E-W Split Phase : N  
 Lost Time (% of cycle) : 10  
 V/C Round Off (decs.) : 3

OLA Movements :  
 FF Movements:

**Date/Time:** AM PEAK HOUR

APPROACH	MVMT	LANES	VOLUME	CAPACITY	V/C	ICU ANALYSIS	
Southbound	RT	0.00	181	0	0.000	N-S(1):	0.357
	TH	4.00	2,033	6,400	0.346 *	N-S(2):	0.437 *
	LT	2.00	130	2,880	0.045	E-W(1):	0.346 *
Westbound	RT	1.00	82	1,600	0.029	E-W(2):	0.321
	TH	2.00	713	3,200	0.223	V/C:	0.783
	LT	2.00	229	2,880	0.080 *	Lost Time:	0.100
Northbound	RT	0.00	199	0	0.000	ITS:	0.000
	TH	4.00	1,798	6,400	0.312	ICU:	0.883
	LT	1.00	146	1,600	0.091 *	LOS:	D
Eastbound	RT	1.00	64	1,600	0.000		
	TH	2.00	852	3,200	0.266 *		
	LT	2.00	283	2,880	0.098		

**Date/Time:** PM PEAK HOUR

APPROACH	MVMT	LANES	VOLUME	CAPACITY	V/C	ICU ANALYSIS	
Southbound	RT	0.00	202	0	0.000	N-S(1):	0.390
	TH	4.00	1,938	6,400	0.334 *	N-S(2):	0.421 *
	LT	2.00	144	2,880	0.050	E-W(1):	0.304
Westbound	RT	1.00	190	1,600	0.094	E-W(2):	0.394 *
	TH	2.00	919	3,200	0.287 *	V/C:	0.815
	LT	2.00	282	2,880	0.098	Lost Time:	0.100
Northbound	RT	0.00	105	0	0.000	ITS:	0.000
	TH	4.00	2,073	6,400	0.340	ICU:	0.915
	LT	1.00	139	1,600	0.087 *	LOS:	E
Eastbound	RT	1.00	124	1,600	0.034		
	TH	2.00	660	3,200	0.206		
	LT	2.00	309	2,880	0.107 *		

\* - Denotes critical movement

**Project Title:** BCHD-HLC  
**Intersection:** 25 - Prospect Av & Torrance Bl  
**Description:** Existing (2020)

Thru Lane: 1600 vph  
 Left Lane: 1600 vph  
 Double Lt Penalty: 10 %  
 ITS: 0 %

N-S Split Phase : N  
 E-W Split Phase : N  
 Lost Time (% of cycle) : 10  
 V/C Round Off (decs.) : 3

OLA Movements :  
 FF Movements:

**Date/Time:** AM PEAK HOUR

APPROACH	MVMT	LANES	VOLUME	CAPACITY	V/C	ICU ANALYSIS	
Southbound	RT	0.00	86	0	0.000	N-S(1):	0.385 *
	TH	2.00	550	3,200	0.199	N-S(2):	0.238
	LT	1.00	174	1,600	0.109 *	E-W(1):	0.187
Westbound	RT	0.00	171	0	0.000	E-W(2):	0.221 *
	TH	3.00	532	4,800	0.146 *	V/C:	0.606
	LT	1.00	122	1,600	0.076	Lost Time:	0.100
Northbound	RT	0.00	201	0	0.000	ITS:	0.000
	TH	2.00	681	3,200	0.276 *	ICU:	0.706
	LT	1.00	62	1,600	0.039	LOS:	C
Eastbound	RT	0.00	26	0	0.000		
	TH	3.00	508	4,800	0.111		
	LT	1.00	120	1,600	0.075 *		

**Date/Time:** PM PEAK HOUR

APPROACH	MVMT	LANES	VOLUME	CAPACITY	V/C	ICU ANALYSIS	
Southbound	RT	0.00	132	0	0.000	N-S(1):	0.369 *
	TH	2.00	802	3,200	0.292	N-S(2):	0.319
	LT	1.00	236	1,600	0.148 *	E-W(1):	0.223
Westbound	RT	0.00	192	0	0.000	E-W(2):	0.249 *
	TH	3.00	636	4,800	0.173 *	V/C:	0.618
	LT	1.00	154	1,600	0.096	Lost Time:	0.100
Northbound	RT	0.00	102	0	0.000	ITS:	0.000
	TH	2.00	604	3,200	0.221 *	ICU:	0.718
	LT	1.00	43	1,600	0.027	LOS:	C
Eastbound	RT	0.00	40	0	0.000		
	TH	3.00	571	4,800	0.127		
	LT	1.00	121	1,600	0.076 *		

\* - Denotes critical movement

Intersection	
Intersection Delay, s/veh	122
Intersection LOS	F

Movement	EBL	EBT	EBR	WBL	WBT	WBR	NBL	NBT	NBR	SBL	SBT	SBR
Lane Configurations		↔↔			↔↔		↔	↑	↔		↔	↔
Traffic Vol, veh/h	47	500	8	33	696	1	54	233	64	106	188	206
Future Vol, veh/h	47	500	8	33	696	1	54	233	64	106	188	206
Peak Hour Factor	0.90	0.90	0.90	0.90	0.90	0.90	0.90	0.90	0.90	0.90	0.90	0.90
Heavy Vehicles, %	2	2	2	2	2	2	2	2	2	2	2	2
Mvmt Flow	52	556	9	37	773	1	60	259	71	118	209	229
Number of Lanes	0	2	0	0	2	0	1	1	1	0	1	1

Approach	EB	WB	NB	SB
Opposing Approach	WB	EB	SB	NB
Opposing Lanes	2	2	2	3
Conflicting Approach Left	SB	NB	EB	WB
Conflicting Lanes Left	2	3	2	2
Conflicting Approach Right	NB	SB	WB	EB
Conflicting Lanes Right	3	2	2	2
HCM Control Delay	95.7	196.9	57.4	87.2
HCM LOS	F	F	F	F

Lane	NBLn1	NBLn2	NBLn3	EBLn1	EBLn2	WBLn1	WBLn2	SBLn1	SBLn2
Vol Left, %	100%	0%	0%	16%	0%	9%	0%	36%	0%
Vol Thru, %	0%	100%	0%	84%	97%	91%	100%	64%	0%
Vol Right, %	0%	0%	100%	0%	3%	0%	0%	0%	100%
Sign Control	Stop	Stop	Stop	Stop	Stop	Stop	Stop	Stop	Stop
Traffic Vol by Lane	54	233	64	297	258	381	349	294	206
LT Vol	54	0	0	47	0	33	0	106	0
Through Vol	0	233	0	250	250	348	348	188	0
RT Vol	0	0	64	0	8	0	1	0	206
Lane Flow Rate	60	259	71	330	287	423	388	327	229
Geometry Grp	8	8	8	8	8	8	8	8	8
Degree of Util (X)	0.22	0.912	0.237	1.083	0.933	1.373	1.253	1.098	0.713
Departure Headway (Hd)	14.697	14.17	13.432	12.591	12.485	12.177	12.129	12.91	11.977
Convergence, Y/N	Yes	Yes	Yes	Yes	Yes	Yes	Yes	Yes	Yes
Cap	246	259	269	290	292	301	302	284	304
Service Time	12.397	11.87	11.132	10.291	10.185	9.877	9.829	10.61	9.677
HCM Lane V/C Ratio	0.244	1	0.264	1.138	0.983	1.405	1.285	1.151	0.753
HCM Control Delay	21.5	75.9	20.3	114.5	74.1	219.5	172.2	120.5	39.6
HCM Lane LOS	C	F	C	F	F	F	F	F	E
HCM 95th-tile Q	0.8	8	0.9	12.4	8.9	21	17.4	12.6	5.1

**Intersection**

Intersection Delay, s/veh 106.4

Intersection LOS F

Movement	EBL	EBT	EBR	WBL	WBT	WBR	NBL	NBT	NBR	SBL	SBT	SBR
Lane Configurations	↖	↕		↖	↕			↕			↕	
Traffic Vol, veh/h	137	575	8	22	488	6	14	19	27	10	8	256
Future Vol, veh/h	137	575	8	22	488	6	14	19	27	10	8	256
Peak Hour Factor	0.80	0.80	0.80	0.80	0.80	0.80	0.80	0.80	0.80	0.80	0.80	0.80
Heavy Vehicles, %	2	2	2	2	2	2	2	2	2	2	2	2
Mvmt Flow	171	719	10	28	610	8	18	24	34	13	10	320
Number of Lanes	1	2	0	1	1	0	0	1	0	0	1	0

Approach	EB	WB	NB	SB
Opposing Approach	WB	EB	SB	NB
Opposing Lanes	2	3	1	1
Conflicting Approach Left	SB	NB	EB	WB
Conflicting Lanes Left	1	1	3	2
Conflicting Approach Right	NB	SB	WB	EB
Conflicting Lanes Right	1	1	2	3
HCM Control Delay	42.4	246.7	15.2	30.3
HCM LOS	E	F	C	D

Lane	NBLn1	EBLn1	EBLn2	EBLn3	WBLn1	WBLn2	SBLn1
Vol Left, %	23%	100%	0%	0%	100%	0%	4%
Vol Thru, %	32%	0%	100%	96%	0%	99%	3%
Vol Right, %	45%	0%	0%	4%	0%	1%	93%
Sign Control	Stop	Stop	Stop	Stop	Stop	Stop	Stop
Traffic Vol by Lane	60	137	383	200	22	494	274
LT Vol	14	137	0	0	22	0	10
Through Vol	19	0	383	192	0	488	8
RT Vol	27	0	0	8	0	6	256
Lane Flow Rate	75	171	479	250	28	618	342
Geometry Grp	7	7	7	7	8	8	7
Degree of Util (X)	0.189	0.371	0.971	0.504	0.071	1.493	0.723
Departure Headway (Hd)	10.124	8.615	8.095	8.066	9.23	8.702	8.445
Convergence, Y/N	Yes	Yes	Yes	Yes	Yes	Yes	Yes
Cap	357	421	450	449	390	420	432
Service Time	7.824	6.315	5.795	5.766	6.934	6.406	6.145
HCM Lane V/C Ratio	0.21	0.406	1.064	0.557	0.072	1.471	0.792
HCM Control Delay	15.2	16.3	64.1	18.7	12.6	257.1	30.3
HCM Lane LOS	C	C	F	C	B	F	D
HCM 95th-tile Q	0.7	1.7	11.9	2.8	0.2	32.6	5.7

**Intersection**

Intersection Delay, s/veh91.7

Intersection LOS F

Movement	EBL	EBT	EBR	WBL	WBT	WBR	NBL	NBT	NBR	SBL	SBT	SBR
Lane Configurations												
Traffic Vol, veh/h	135	446	40	10	358	9	15	158	48	9	71	133
Future Vol, veh/h	135	446	40	10	358	9	15	158	48	9	71	133
Peak Hour Factor	0.82	0.82	0.82	0.82	0.82	0.82	0.82	0.82	0.82	0.82	0.82	0.82
Heavy Vehicles, %	2	2	2	2	2	2	2	2	2	2	2	2
Mvmt Flow	165	544	49	12	437	11	18	193	59	11	87	162
Number of Lanes	1	1	1	0	1	0	0	1	0	0	1	1

Approach	EB	WB	NB	SB
Opposing Approach	WB	EB	SB	NB
Opposing Lanes	1	3	2	1
Conflicting Approach Left SB		NB	EB	WB
Conflicting Lanes Left	2	1	3	1
Conflicting Approach Right NB		SB	WB	EB
Conflicting Lanes Right	1	2	1	3
HCM Control Delay	112.7	131	35.7	19
HCM LOS	F	F	E	C

Lane	NBLn1	EBLn1	EBLn2	EBLn3	WBLn1	SBLn1	SBLn2
Vol Left, %	7%	100%	0%	0%	3%	11%	0%
Vol Thru, %	71%	0%	100%	0%	95%	89%	0%
Vol Right, %	22%	0%	0%	100%	2%	0%	100%
Sign Control	Stop	Stop	Stop	Stop	Stop	Stop	Stop
Traffic Vol by Lane	221	135	446	40	377	80	133
LT Vol	15	135	0	0	10	9	0
Through Vol	158	0	446	0	358	71	0
RT Vol	48	0	0	40	9	0	133
Lane Flow Rate	270	165	544	49	460	98	162
Geometry Grp	8	7	7	7	8	8	8
Degree of Util (X)	0.716	0.396	1.233	0.101	1.168	0.27	0.415
Departure Headway (Hd)	10.494	9.136	8.616	7.888	9.692	10.935	10.137
Convergence, Y/N	Yes	Yes	Yes	Yes	Yes	Yes	Yes
Cap	348	397	424	457	377	331	357
Service Time	8.194	6.836	6.316	5.588	7.392	8.635	7.837
HCM Lane V/C Ratio	0.776	0.416	1.283	0.107	1.22	0.296	0.454
HCM Control Delay	35.7	17.7	150.5	11.5	131	17.6	19.8
HCM Lane LOS	E	C	F	B	F	C	C
HCM 95th-tile Q	5.3	1.9	21.3	0.3	17.2	1.1	2

HCM 6th TWSC  
 12: Prospect Av & BCHD North Driveway

02/19/2021

Intersection						
Int Delay, s/veh	0.1					
Movement	WBL	WBR	NBT	NBR	SBL	SBT
Lane Configurations		↗	↕			↕
Traffic Vol, veh/h	0	18	1083	7	0	900
Future Vol, veh/h	0	18	1083	7	0	900
Conflicting Peds, #/hr	0	0	0	0	0	0
Sign Control	Stop	Stop	Free	Free	Free	Free
RT Channelized	-	None	-	None	-	None
Storage Length	-	0	-	-	-	-
Veh in Median Storage, #	0	-	0	-	-	0
Grade, %	0	-	0	-	-	0
Peak Hour Factor	81	81	81	81	81	81
Heavy Vehicles, %	2	2	2	2	2	2
Mvmt Flow	0	22	1337	9	0	1111

Major/Minor	Minor1	Major1	Major2		
Conflicting Flow All	-	673	0	0	-
Stage 1	-	-	-	-	-
Stage 2	-	-	-	-	-
Critical Hdwy	-	6.94	-	-	-
Critical Hdwy Stg 1	-	-	-	-	-
Critical Hdwy Stg 2	-	-	-	-	-
Follow-up Hdwy	-	3.32	-	-	-
Pot Cap-1 Maneuver	0	398	-	-	0
Stage 1	0	-	-	-	0
Stage 2	0	-	-	-	0
Platoon blocked, %			-	-	-
Mov Cap-1 Maneuver	-	398	-	-	-
Mov Cap-2 Maneuver	-	-	-	-	-
Stage 1	-	-	-	-	-
Stage 2	-	-	-	-	-

Approach	WB	NB	SB
HCM Control Delay, s	14.6	0	0
HCM LOS	B		

Minor Lane/Major Mvmt	NBT	NBRWBLn1	SBT
Capacity (veh/h)	-	-	398
HCM Lane V/C Ratio	-	-	0.056
HCM Control Delay (s)	-	-	14.6
HCM Lane LOS	-	-	B
HCM 95th %tile Q(veh)	-	-	0.2



HCM 6th TWSC  
 14: BCHD South Driveway & Prospect Av

02/19/2021

Intersection						
Int Delay, s/veh	0.1					
Movement	WBL	WBR	NBT	NBR	SBL	SBT
Lane Configurations		↗	↕			↕
Traffic Vol, veh/h	0	14	1141	87	0	801
Future Vol, veh/h	0	14	1141	87	0	801
Conflicting Peds, #/hr	0	0	0	0	0	0
Sign Control	Stop	Stop	Free	Free	Free	Free
RT Channelized	-	None	-	None	-	None
Storage Length	-	0	-	-	-	-
Veh in Median Storage, #	0	-	0	-	-	0
Grade, %	0	-	0	-	-	0
Peak Hour Factor	80	80	80	80	80	80
Heavy Vehicles, %	2	2	2	2	2	2
Mvmt Flow	0	18	1426	109	0	1001

Major/Minor	Minor1	Major1	Major2		
Conflicting Flow All	-	768	0	0	-
Stage 1	-	-	-	-	-
Stage 2	-	-	-	-	-
Critical Hdwy	-	6.94	-	-	-
Critical Hdwy Stg 1	-	-	-	-	-
Critical Hdwy Stg 2	-	-	-	-	-
Follow-up Hdwy	-	3.32	-	-	-
Pot Cap-1 Maneuver	0	344	-	-	0
Stage 1	0	-	-	-	0
Stage 2	0	-	-	-	0
Platoon blocked, %			-	-	-
Mov Cap-1 Maneuver	-	344	-	-	-
Mov Cap-2 Maneuver	-	-	-	-	-
Stage 1	-	-	-	-	-
Stage 2	-	-	-	-	-

Approach	WB	NB	SB
HCM Control Delay, s	16	0	0
HCM LOS	C		

Minor Lane/Major Mvmt	NBT	NBRWBLn1	SBT
Capacity (veh/h)	-	-	344
HCM Lane V/C Ratio	-	-	0.051
HCM Control Delay (s)	-	-	16
HCM Lane LOS	-	-	C
HCM 95th %tile Q(veh)	-	-	0.2

Intersection						
Int Delay, s/veh	5.2					
Movement	EBL	EBT	WBT	WBR	SBL	SBR
Lane Configurations	↘	↑↑	↑↑		↘	↘
Traffic Vol, veh/h	50	570	735	105	64	44
Future Vol, veh/h	50	570	735	105	64	44
Conflicting Peds, #/hr	0	0	0	0	0	0
Sign Control	Free	Free	Free	Free	Stop	Stop
RT Channelized	-	None	-	None	-	None
Storage Length	100	-	-	-	0	50
Veh in Median Storage, #	-	0	0	-	0	-
Grade, %	-	0	0	-	0	-
Peak Hour Factor	79	79	79	79	79	79
Heavy Vehicles, %	2	2	2	2	2	2
Mvmt Flow	63	722	930	133	81	56

Major/Minor	Major1	Major2	Minor2		
Conflicting Flow All	1063	0	-	0	1484 532
Stage 1	-	-	-	-	997 -
Stage 2	-	-	-	-	487 -
Critical Hdwy	4.14	-	-	-	6.84 6.94
Critical Hdwy Stg 1	-	-	-	-	5.84 -
Critical Hdwy Stg 2	-	-	-	-	5.84 -
Follow-up Hdwy	2.22	-	-	-	3.52 3.32
Pot Cap-1 Maneuver	651	-	-	-	116 492
Stage 1	-	-	-	-	318 -
Stage 2	-	-	-	-	583 -
Platoon blocked, %		-	-	-	
Mov Cap-1 Maneuver	651	-	-	-	105 492
Mov Cap-2 Maneuver	-	-	-	-	105 -
Stage 1	-	-	-	-	287 -
Stage 2	-	-	-	-	583 -

Approach	EB	WB	SB
HCM Control Delay, s	0.9	0	69.7
HCM LOS			F

Minor Lane/Major Mvmt	EBL	EBT	WBT	WBR	SBLn1	SBLn2
Capacity (veh/h)	651	-	-	-	105	492
HCM Lane V/C Ratio	0.097	-	-	-	0.772	0.113
HCM Control Delay (s)	11.1	-	-	-	108.5	13.2
HCM Lane LOS	B	-	-	-	F	B
HCM 95th %tile Q(veh)	0.3	-	-	-	4.2	0.4

Intersection	
Intersection Delay, s/veh	80.9
Intersection LOS	F

Movement	EBL	EBT	EBR	WBL	WBT	WBR	NBL	NBT	NBR	SBL	SBT	SBR
Lane Configurations		↔↔			↔↔		↗	↑	↖		↖	↗
Traffic Vol, veh/h	76	570	22	39	568	0	25	133	45	130	157	120
Future Vol, veh/h	76	570	22	39	568	0	25	133	45	130	157	120
Peak Hour Factor	0.91	0.91	0.91	0.91	0.91	0.91	0.91	0.91	0.91	0.91	0.91	0.91
Heavy Vehicles, %	2	2	2	2	2	2	2	2	2	2	2	2
Mvmt Flow	84	626	24	43	624	0	27	146	49	143	173	132
Number of Lanes	0	2	0	0	2	0	1	1	1	0	1	1

Approach	EB	WB	NB	SB
Opposing Approach	WB	EB	SB	NB
Opposing Lanes	2	2	2	3
Conflicting Approach Left	SB	NB	EB	WB
Conflicting Lanes Left	2	3	2	2
Conflicting Approach Right	NB	SB	WB	EB
Conflicting Lanes Right	3	2	2	2
HCM Control Delay	95.2	101.3	22.5	56.1
HCM LOS	F	F	C	F

Lane	NBLn1	NBLn2	NBLn3	EBLn1	EBLn2	WBLn1	WBLn2	SBLn1	SBLn2
Vol Left, %	100%	0%	0%	21%	0%	17%	0%	45%	0%
Vol Thru, %	0%	100%	0%	79%	93%	83%	100%	55%	0%
Vol Right, %	0%	0%	100%	0%	7%	0%	0%	0%	100%
Sign Control	Stop	Stop	Stop	Stop	Stop	Stop	Stop	Stop	Stop
Traffic Vol by Lane	25	133	45	361	307	228	379	287	120
LT Vol	25	0	0	76	0	39	0	130	0
Through Vol	0	133	0	285	285	189	379	157	0
RT Vol	0	0	45	0	22	0	0	0	120
Lane Flow Rate	27	146	49	397	337	251	416	315	132
Geometry Grp	8	8	8	8	8	8	8	8	8
Degree of Util (X)	0.093	0.474	0.151	1.122	0.94	0.72	1.184	0.941	0.36
Departure Headway (Hd)	12.837	12.309	11.57	10.596	10.434	10.647	10.559	11.419	10.443
Convergence, Y/N	Yes	Yes	Yes	Yes	Yes	Yes	Yes	Yes	Yes
Cap	281	295	312	345	351	341	345	319	347
Service Time	10.537	10.009	9.27	8.296	8.134	8.347	8.259	9.119	8.143
HCM Lane V/C Ratio	0.096	0.495	0.157	1.151	0.96	0.736	1.206	0.987	0.38
HCM Control Delay	16.8	25.6	16.3	118.9	67.4	36.5	140.3	71.6	18.9
HCM Lane LOS	C	D	C	F	F	E	F	F	C
HCM 95th-tile Q	0.3	2.4	0.5	14.8	9.8	5.3	16.8	9.4	1.6

**Intersection**

Intersection Delay, s/veh 46.4

Intersection LOS E

Movement	EBL	EBT	EBR	WBL	WBT	WBR	NBL	NBT	NBR	SBL	SBT	SBR
Lane Configurations	↖	↕		↖	↕			↕			↕	
Traffic Vol, veh/h	87	554	22	51	438	26	36	31	56	18	23	118
Future Vol, veh/h	87	554	22	51	438	26	36	31	56	18	23	118
Peak Hour Factor	0.90	0.90	0.90	0.90	0.90	0.90	0.90	0.90	0.90	0.90	0.90	0.90
Heavy Vehicles, %	2	2	2	2	2	2	2	2	2	2	2	2
Mvmt Flow	97	616	24	57	487	29	40	34	62	20	26	131
Number of Lanes	1	2	0	1	1	0	0	1	0	0	1	0

Approach	EB	WB	NB	SB
Opposing Approach	WB	EB	SB	NB
Opposing Lanes	2	3	1	1
Conflicting Approach Left SB		NB	EB	WB
Conflicting Lanes Left	1	1	3	2
Conflicting Approach Right NB		SB	WB	EB
Conflicting Lanes Right	1	1	2	3
HCM Control Delay	22.8	93.6	15.1	15.7
HCM LOS	C	F	C	C

Lane	NBLn1	EBLn1	EBLn2	EBLn3	WBLn1	WBLn2	SBLn1
Vol Left, %	29%	100%	0%	0%	100%	0%	11%
Vol Thru, %	25%	0%	100%	89%	0%	94%	14%
Vol Right, %	46%	0%	0%	11%	0%	6%	74%
Sign Control	Stop	Stop	Stop	Stop	Stop	Stop	Stop
Traffic Vol by Lane	123	87	369	207	51	464	159
LT Vol	36	87	0	0	51	0	18
Through Vol	31	0	369	185	0	438	23
RT Vol	56	0	0	22	0	26	118
Lane Flow Rate	137	97	410	230	57	516	177
Geometry Grp	7	7	7	7	8	8	7
Degree of Util (X)	0.31	0.195	0.772	0.427	0.131	1.111	0.38
Departure Headway (Hd)	8.563	7.591	7.078	7.001	8.312	7.758	8.119
Convergence, Y/N	Yes	Yes	Yes	Yes	Yes	Yes	Yes
Cap	422	476	513	517	434	474	445
Service Time	6.263	5.291	4.778	4.701	6.012	5.458	5.819
HCM Lane V/C Ratio	0.325	0.204	0.799	0.445	0.131	1.089	0.398
HCM Control Delay	15.1	12.1	29.8	14.8	12.3	102.5	15.7
HCM Lane LOS	C	B	D	B	B	F	C
HCM 95th-tile Q	1.3	0.7	6.9	2.1	0.4	17.5	1.7

**Intersection**

Intersection Delay, s/veh45.3

Intersection LOS E

Movement	EBL	EBT	EBR	WBL	WBT	WBR	NBL	NBT	NBR	SBL	SBT	SBR
Lane Configurations												
Traffic Vol, veh/h	109	499	56	18	389	10	21	42	17	22	77	92
Future Vol, veh/h	109	499	56	18	389	10	21	42	17	22	77	92
Peak Hour Factor	0.95	0.95	0.95	0.95	0.95	0.95	0.95	0.95	0.82	0.82	0.82	0.82
Heavy Vehicles, %	2	2	2	2	2	2	2	2	2	2	2	2
Mvmt Flow	115	525	59	19	409	11	22	44	21	27	94	112
Number of Lanes	1	1	1	0	1	0	0	1	0	0	1	1

Approach	EB	WB	NB	SB
Opposing Approach	WB	EB	SB	NB
Opposing Lanes	1	3	2	1
Conflicting Approach Left SB		NB	EB	WB
Conflicting Lanes Left	2	1	3	1
Conflicting Approach Right NB		SB	WB	EB
Conflicting Lanes Right	1	2	1	3
HCM Control Delay	50.6	59.3	15	14.6
HCM LOS	F	F	B	B

Lane	NBLn1	EBLn1	EBLn2	EBLn3	WBLn1	SBLn1	SBLn2
Vol Left, %	26%	100%	0%	0%	4%	22%	0%
Vol Thru, %	53%	0%	100%	0%	93%	78%	0%
Vol Right, %	21%	0%	0%	100%	2%	0%	100%
Sign Control	Stop	Stop	Stop	Stop	Stop	Stop	Stop
Traffic Vol by Lane	80	109	499	56	417	99	92
LT Vol	21	109	0	0	18	22	0
Through Vol	42	0	499	0	389	77	0
RT Vol	17	0	0	56	10	0	92
Lane Flow Rate	87	115	525	59	439	121	112
Geometry Grp	8	7	7	7	8	8	8
Degree of Util (X)	0.229	0.233	0.993	0.1	0.953	0.302	0.254
Departure Headway (Hd)	9.459	7.317	6.805	6.089	7.917	9.002	8.162
Convergence, Y/N	Yes	Yes	Yes	Yes	Yes	Yes	Yes
Cap	381	488	531	584	461	402	443
Service Time	7.171	5.108	4.596	3.879	5.617	6.702	5.862
HCM Lane V/C Ratio	0.228	0.236	0.989	0.101	0.952	0.301	0.253
HCM Control Delay	15	12.3	63.6	9.6	59.3	15.5	13.6
HCM Lane LOS	B	B	F	A	F	C	B
HCM 95th-tile Q	0.9	0.9	13.7	0.3	11.5	1.3	1

HCM 6th TWSC  
 12: Prospect Av & BCHD North Driveway

02/19/2021

Intersection						
Int Delay, s/veh	0.3					
Movement	WBL	WBR	NBT	NBR	SBL	SBT
Lane Configurations		↗	↕			↕
Traffic Vol, veh/h	0	55	865	0	0	1042
Future Vol, veh/h	0	55	865	0	0	1042
Conflicting Peds, #/hr	0	0	0	0	0	0
Sign Control	Stop	Stop	Free	Free	Free	Free
RT Channelized	-	None	-	None	-	None
Storage Length	-	0	-	-	-	-
Veh in Median Storage, #	0	-	0	-	-	0
Grade, %	0	-	0	-	-	0
Peak Hour Factor	96	96	96	96	96	96
Heavy Vehicles, %	2	2	2	2	2	2
Mvmt Flow	0	57	901	0	0	1085

Major/Minor	Minor1	Major1	Major2		
Conflicting Flow All	-	451	0	0	-
Stage 1	-	-	-	-	-
Stage 2	-	-	-	-	-
Critical Hdwy	-	6.94	-	-	-
Critical Hdwy Stg 1	-	-	-	-	-
Critical Hdwy Stg 2	-	-	-	-	-
Follow-up Hdwy	-	3.32	-	-	-
Pot Cap-1 Maneuver	0	556	-	-	0
Stage 1	0	-	-	-	0
Stage 2	0	-	-	-	0
Platoon blocked, %			-	-	-
Mov Cap-1 Maneuver	-	556	-	-	-
Mov Cap-2 Maneuver	-	-	-	-	-
Stage 1	-	-	-	-	-
Stage 2	-	-	-	-	-

Approach	WB	NB	SB
HCM Control Delay, s	12.2	0	0
HCM LOS	B		

Minor Lane/Major Mvmt	NBT	NBRWBLn1	SBT
Capacity (veh/h)	-	-	556
HCM Lane V/C Ratio	-	-	0.103
HCM Control Delay (s)	-	-	12.2
HCM Lane LOS	-	-	B
HCM 95th %tile Q(veh)	-	-	0.3

HCM 6th TWSC  
 14: BCHD South Driveway & Prospect Av

02/19/2021

Intersection						
Int Delay, s/veh	0.3					
Movement	WBL	WBR	NBT	NBR	SBL	SBT
Lane Configurations		↗	↕			↕
Traffic Vol, veh/h	0	42	760	36	0	1099
Future Vol, veh/h	0	42	760	36	0	1099
Conflicting Peds, #/hr	0	0	0	0	0	0
Sign Control	Stop	Stop	Free	Free	Free	Free
RT Channelized	-	None	-	None	-	None
Storage Length	-	0	-	-	-	-
Veh in Median Storage, #	0	-	0	-	-	0
Grade, %	0	-	0	-	-	0
Peak Hour Factor	96	96	96	96	96	96
Heavy Vehicles, %	2	2	2	2	2	2
Mvmt Flow	0	44	792	38	0	1145

Major/Minor	Minor1	Major1	Major2		
Conflicting Flow All	-	415	0	0	-
Stage 1	-	-	-	-	-
Stage 2	-	-	-	-	-
Critical Hdwy	-	6.94	-	-	-
Critical Hdwy Stg 1	-	-	-	-	-
Critical Hdwy Stg 2	-	-	-	-	-
Follow-up Hdwy	-	3.32	-	-	-
Pot Cap-1 Maneuver	0	586	-	-	0
Stage 1	0	-	-	-	0
Stage 2	0	-	-	-	0
Platoon blocked, %			-	-	-
Mov Cap-1 Maneuver	-	586	-	-	-
Mov Cap-2 Maneuver	-	-	-	-	-
Stage 1	-	-	-	-	-
Stage 2	-	-	-	-	-

Approach	WB	NB	SB
HCM Control Delay, s	11.6	0	0
HCM LOS	B		

Minor Lane/Major Mvmt	NBT	NBRWBLn1	SBT
Capacity (veh/h)	-	-	586
HCM Lane V/C Ratio	-	-	0.075
HCM Control Delay (s)	-	-	11.6
HCM Lane LOS	-	-	B
HCM 95th %tile Q(veh)	-	-	0.2

Intersection						
Int Delay, s/veh	2.5					
Movement	EBL	EBT	WBT	WBR	SBL	SBR
Lane Configurations	↖	↑↑	↑↑		↖	↖
Traffic Vol, veh/h	15	616	682	95	91	22
Future Vol, veh/h	15	616	682	95	91	22
Conflicting Peds, #/hr	0	0	0	0	0	0
Sign Control	Free	Free	Free	Free	Stop	Stop
RT Channelized	-	None	-	None	-	None
Storage Length	100	-	-	-	0	50
Veh in Median Storage, #	-	0	0	-	0	-
Grade, %	-	0	0	-	0	-
Peak Hour Factor	97	97	97	97	97	97
Heavy Vehicles, %	2	2	2	2	2	2
Mvmt Flow	15	635	703	98	94	23

Major/Minor	Major1	Major2	Minor2		
Conflicting Flow All	801	0	-	0	1100 401
Stage 1	-	-	-	-	752 -
Stage 2	-	-	-	-	348 -
Critical Hdwy	4.14	-	-	-	6.84 6.94
Critical Hdwy Stg 1	-	-	-	-	5.84 -
Critical Hdwy Stg 2	-	-	-	-	5.84 -
Follow-up Hdwy	2.22	-	-	-	3.52 3.32
Pot Cap-1 Maneuver	818	-	-	-	206 599
Stage 1	-	-	-	-	426 -
Stage 2	-	-	-	-	686 -
Platoon blocked, %		-	-	-	
Mov Cap-1 Maneuver	818	-	-	-	202 599
Mov Cap-2 Maneuver	-	-	-	-	202 -
Stage 1	-	-	-	-	418 -
Stage 2	-	-	-	-	686 -

Approach	EB	WB	SB
HCM Control Delay, s	0.2	0	32.3
HCM LOS			D

Minor Lane/Major Mvmt	EBL	EBT	WBT	WBR	SBLn1	SBLn2
Capacity (veh/h)	818	-	-	-	202	599
HCM Lane V/C Ratio	0.019	-	-	-	0.464	0.038
HCM Control Delay (s)	9.5	-	-	-	37.4	11.2
HCM Lane LOS	A	-	-	-	E	B
HCM 95th %tile Q(veh)	0.1	-	-	-	2.2	0.1



# Cumulative (2032) Baseline Conditions

**Project Title:** BCHD-HLC  
**Intersection:** 1 - Prospect Av & Anita St  
**Description:** Future Base (2032)

Thru Lane: 1600 vph  
 Left Lane: 1600 vph  
 Double Lt Penalty: 10 %  
 ITS: 0 %

N-S Split Phase : N  
 E-W Split Phase : N  
 Lost Time (% of cycle) : 10  
 V/C Round Off (decs.) : 3

OLA Movements :  
 FF Movements:

**Date/Time:** AM PEAK HOUR

APPROACH	MVMT	LANES	VOLUME	CAPACITY	V/C	ICU ANALYSIS	
Southbound	RT	0.00	33	0	0.000	N-S(1):	0.302 *
	TH	2.00	361	3,200	0.123	N-S(2):	0.287
	LT	1.00	63	1,600	0.039 *	E-W(1):	0.254
Westbound	RT	0.00	74	0	0.000	E-W(2):	0.275 *
	TH	2.00	752	3,200	0.258 *	V/C:	0.577
	LT	1.00	163	1,600	0.102	Lost Time:	0.100
Northbound	RT	1.00	208	1,600	0.079	ITS:	0.000
	TH	1.00	420	1,600	0.263 *	ICU:	0.677
	LT	1.00	262	1,600	0.164	LOS:	B
Eastbound	RT	0.00	85	0	0.000		
	TH	2.00	402	3,200	0.152		
	LT	1.00	27	1,600	0.017 *		

**Date/Time:** PM PEAK HOUR

APPROACH	MVMT	LANES	VOLUME	CAPACITY	V/C	ICU ANALYSIS	
Southbound	RT	0.00	40	0	0.000	N-S(1):	0.261
	TH	2.00	561	3,200	0.188 *	N-S(2):	0.262 *
	LT	1.00	73	1,600	0.046	E-W(1):	0.309 *
Westbound	RT	0.00	85	0	0.000	E-W(2):	0.247
	TH	2.00	628	3,200	0.223	V/C:	0.571
	LT	1.00	131	1,600	0.082 *	Lost Time:	0.100
Northbound	RT	1.00	94	1,600	0.018	ITS:	0.000
	TH	1.00	344	1,600	0.215	ICU:	0.671
	LT	1.00	118	1,600	0.074 *	LOS:	B
Eastbound	RT	0.00	122	0	0.000		
	TH	2.00	604	3,200	0.227 *		
	LT	1.00	39	1,600	0.024		

\* - Denotes critical movement

**Project Title:** BCHD-HLC  
**Intersection:** 2 - Harkness Ln & Anita St  
**Description:** Future Base (2032)

Thru Lane: 1600 vph  
 Left Lane: 1600 vph  
 Double Lt Penalty: 10 %  
 ITS: 0 %

N-S Split Phase : N  
 E-W Split Phase : N  
 Lost Time (% of cycle) : 10  
 V/C Round Off (decs.) : 3

OLA Movements :  
 FF Movements:

**Date/Time:** AM PEAK HOUR

APPROACH	MVMT	LANES	VOLUME	CAPACITY	V/C	ICU ANALYSIS	
Southbound	RT	0.00	69	0	0.000	N-S(1):	0.132
	TH	1.00	118	1,600	0.138 *	N-S(2):	0.249 *
	LT	0.00	33	1,600	0.021	E-W(1):	0.236
Westbound	RT	0.00	22	0	0.000	E-W(2):	0.312 *
	TH	2.00	869	3,200	0.278 *	V/C:	0.561
	LT	1.00	116	1,600	0.073	Lost Time:	0.100
Northbound	RT	1.00	27	1,600	0.000	ITS:	0.000
	TH	0.78	138	1,247	0.111		
	LT	0.22	39	353	0.111 *		
Eastbound	RT	1.00	21	1,600	0.000	ICU:	0.661
	TH	2.00	521	3,200	0.163		
	LT	1.00	54	1,600	0.034 *	LOS:	B

**Date/Time:** PM PEAK HOUR

APPROACH	MVMT	LANES	VOLUME	CAPACITY	V/C	ICU ANALYSIS	
Southbound	RT	0.00	49	0	0.000	N-S(1):	0.064
	TH	1.00	97	1,600	0.106 *	N-S(2):	0.155 *
	LT	0.00	24	1,600	0.015	E-W(1):	0.237
Westbound	RT	0.00	9	0	0.000	E-W(2):	0.253 *
	TH	2.00	701	3,200	0.222 *	V/C:	0.408
	LT	1.00	35	1,600	0.022	Lost Time:	0.100
Northbound	RT	1.00	5	1,600	0.000	ITS:	0.000
	TH	0.84	66	1,337	0.049		
	LT	0.16	13	263	0.049 *		
Eastbound	RT	1.00	44	1,600	0.003	ICU:	0.508
	TH	2.00	688	3,200	0.215		
	LT	1.00	49	1,600	0.031 *	LOS:	A

\* - Denotes critical movement

**Project Title:** BCHD-HLC  
**Intersection:** 4 - Beryl St/Blossom Ln & 190th St  
**Description:** Future Base (2032)

Thru Lane: 1600 vph  
 Left Lane: 1600 vph  
 Double Lt Penalty: 10 %  
 ITS: 0 %

N-S Split Phase : N  
 E-W Split Phase : N  
 Lost Time (% of cycle) : 10  
 V/C Round Off (decs.) : 3

OLA Movements :  
 FF Movements:

**Date/Time:** AM PEAK HOUR

APPROACH	MVMT	LANES	VOLUME	CAPACITY	V/C	ICU ANALYSIS	
Southbound	RT	1.00	23	1,600	0.008	N-S(1):	0.213 *
	TH	0.45	33	723	0.046	N-S(2):	0.052
	LT	0.55	40	877	0.046 *	E-W(1):	0.447 *
Westbound	RT	0.00	42	0	0.000	E-W(2):	0.274
	TH	2.00	797	3,200	0.262	V/C:	0.660
	LT	1.00	373	1,600	0.233 *	Lost Time:	0.100
Northbound	RT	1.00	453	1,600	0.167 *	ITS:	0.000
	TH	1.00	100	1,600	0.063	ICU:	0.760
	LT	1.00	9	1,600	0.006	LOS:	C
Eastbound	RT	1.00	10	1,600	0.003		
	TH	2.00	686	3,200	0.214 *		
	LT	1.00	19	1,600	0.012		

**Date/Time:** PM PEAK HOUR

APPROACH	MVMT	LANES	VOLUME	CAPACITY	V/C	ICU ANALYSIS	
Southbound	RT	1.00	17	1,600	0.007	N-S(1):	0.221 *
	TH	0.68	47	1,090	0.043	N-S(2):	0.046
	LT	0.32	22	510	0.043 *	E-W(1):	0.497 *
Westbound	RT	0.00	43	0	0.000	E-W(2):	0.270
	TH	2.00	795	3,200	0.262	V/C:	0.718
	LT	1.00	403	1,600	0.252 *	Lost Time:	0.100
Northbound	RT	1.00	487	1,600	0.178 *	ITS:	0.000
	TH	1.00	99	1,600	0.062	ICU:	0.818
	LT	1.00	4	1,600	0.003	LOS:	D
Eastbound	RT	1.00	13	1,600	0.007		
	TH	2.00	784	3,200	0.245 *		
	LT	1.00	13	1,600	0.008		

\* - Denotes critical movement

**Project Title:** BCHD-HLC  
**Intersection:** 5 - Entradero Av/Meyer Ln & 190th St  
**Description:** Future Base (2032)

Thru Lane: 1600 vph  
 Left Lane: 1600 vph  
 Double Lt Penalty: 10 %  
 ITS: 0 %

N-S Split Phase : N  
 E-W Split Phase : N  
 Lost Time (% of cycle) : 10  
 V/C Round Off (decs.) : 3

OLA Movements :  
 FF Movements:

**Date/Time:** AM PEAK HOUR

APPROACH	MVMT	LANES	VOLUME	CAPACITY	V/C	ICU ANALYSIS	
Southbound	RT	0.00	30	0	0.000	N-S(1):	0.258 *
	TH	1.00	83	1,600	0.141	N-S(2):	0.188
	LT	0.00	112	1,600	0.070 *	E-W(1):	0.456 *
Westbound	RT	1.00	106	1,600	0.031	E-W(2):	0.422
	TH	2.00	1,288	3,200	0.403	V/C:	0.714
	LT	1.00	100	1,600	0.063 *	Lost Time:	0.100
Northbound	RT	0.00	113	0	0.000	ITS:	0.000
	TH	1.00	113	1,600	0.188 *	ICU:	0.814
	LT	0.00	75	1,600	0.047	LOS:	D
Eastbound	RT	1.00	49	1,600	0.007		
	TH	2.00	1,257	3,200	0.393 *		
	LT	1.00	30	1,600	0.019		

**Date/Time:** PM PEAK HOUR

APPROACH	MVMT	LANES	VOLUME	CAPACITY	V/C	ICU ANALYSIS	
Southbound	RT	0.00	33	0	0.000	N-S(1):	0.180 *
	TH	1.00	71	1,600	0.121	N-S(2):	0.149
	LT	0.00	89	1,600	0.056 *	E-W(1):	0.475 *
Westbound	RT	1.00	109	1,600	0.040	E-W(2):	0.460
	TH	2.00	1,370	3,200	0.428	V/C:	0.655
	LT	1.00	83	1,600	0.052 *	Lost Time:	0.100
Northbound	RT	0.00	94	0	0.000	ITS:	0.000
	TH	1.00	61	1,600	0.124 *	ICU:	0.755
	LT	0.00	44	1,600	0.028	LOS:	C
Eastbound	RT	1.00	88	1,600	0.041		
	TH	2.00	1,354	3,200	0.423 *		
	LT	1.00	51	1,600	0.032		

\* - Denotes critical movement

**Project Title: BCHD-HLC**  
**Intersection: 6 - Anza Av & 190th St**  
**Description: Future Base (2032)**

Thru Lane: 1600 vph  
 Left Lane: 1600 vph  
 Double Lt Penalty: 10 %  
 ITS: 0 %

N-S Split Phase : N  
 E-W Split Phase : N  
 Lost Time (% of cycle) : 10  
 V/C Round Off (decs.) : 3

OLA Movements :  
 FF Movements:

**Date/Time: AM PEAK HOUR**

APPROACH	MVMT	LANES	VOLUME	CAPACITY	V/C	ICU ANALYSIS	
Southbound	RT	0.00	0	0	0.000	N-S(1):	0.255 *
	TH	0.00	0	0	0.000	N-S(2):	0.200
	LT	0.00	0	0	0.000 *	E-W(1):	0.481 *
Westbound	RT	0.00	0	0	0.000	E-W(2):	0.295
	TH	2.00	943	3,200	0.295	V/C:	0.736
	LT	2.00	485	2,880	0.168 *	Lost Time:	0.100
Northbound	RT	1.00	542	1,600	0.255 *	ITS:	0.000
	TH	0.00	0	0	0.000	ICU:	0.836
	LT	2.00	577	2,880	0.200	LOS:	D
Eastbound	RT	1.00	366	1,600	0.229		
	TH	2.00	1,003	3,200	0.313 *		
	LT	0.00	0	0	0.000		

**Date/Time: PM PEAK HOUR**

APPROACH	MVMT	LANES	VOLUME	CAPACITY	V/C	ICU ANALYSIS	
Southbound	RT	0.00	0	0	0.000	N-S(1):	0.236 *
	TH	0.00	0	0	0.000	N-S(2):	0.217
	LT	0.00	0	0	0.000 *	E-W(1):	0.544 *
Westbound	RT	0.00	0	0	0.000	E-W(2):	0.304
	TH	2.00	973	3,200	0.304	V/C:	0.780
	LT	2.00	602	2,880	0.209 *	Lost Time:	0.100
Northbound	RT	1.00	545	1,600	0.236 *	ITS:	0.000
	TH	0.00	0	0	0.000	ICU:	0.880
	LT	2.00	625	2,880	0.217	LOS:	D
Eastbound	RT	1.00	521	1,600	0.326		
	TH	2.00	1,073	3,200	0.335 *		
	LT	0.00	0	0	0.000		

\* - Denotes critical movement

**Project Title:** BCHD-HLC  
**Intersection:** 7 - Inglewood Ave & 190th St  
**Description:** Future Base (2032)

Thru Lane: 1600 vph  
 Left Lane: 1600 vph  
 Double Lt Penalty: 10 %  
 ITS: 0 %

N-S Split Phase : N  
 E-W Split Phase : N  
 Lost Time (% of cycle) : 10  
 V/C Round Off (decs.) : 3

OLA Movements :  
 FF Movements:

**Date/Time:** AM PEAK HOUR

APPROACH	MVMT	LANES	VOLUME	CAPACITY	V/C	ICU ANALYSIS	
Southbound	RT	1.00	576	1,600	0.255 *	N-S(1):	0.260
	TH	0.11	33	175	0.189	N-S(2):	0.265 *
	LT	0.89	269	1,425	0.189	E-W(1):	0.306
Westbound	RT	0.00	181	0	0.000	E-W(2):	0.428 *
	TH	3.00	871	4,800	0.219 *	V/C:	0.693
	LT	1.00	20	1,600	0.013	Lost Time:	0.100
Northbound	RT	0.00	29	0	0.000	ITS:	0.000
	TH	1.00	68	1,600	0.071	ICU:	0.793
	LT	0.00	16	1,600	0.010 *	LOS:	C
Eastbound	RT	0.00	5	0	0.000		
	TH	2.00	932	3,200	0.293		
	LT	2.00	602	2,880	0.209 *		

**Date/Time:** PM PEAK HOUR

APPROACH	MVMT	LANES	VOLUME	CAPACITY	V/C	ICU ANALYSIS	
Southbound	RT	1.00	597	1,600	0.258	N-S(1):	0.317 *
	TH	0.21	73	336	0.218	N-S(2):	0.279
	LT	0.79	275	1,264	0.218 *	E-W(1):	0.332
Westbound	RT	0.00	219	0	0.000	E-W(2):	0.489 *
	TH	3.00	1,024	4,800	0.259 *	V/C:	0.806
	LT	1.00	59	1,600	0.037	Lost Time:	0.100
Northbound	RT	0.00	16	0	0.000	ITS:	0.000
	TH	1.00	109	1,600	0.099 *	ICU:	0.906
	LT	0.00	34	1,600	0.021	LOS:	E
Eastbound	RT	0.00	15	0	0.000		
	TH	2.00	930	3,200	0.295		
	LT	2.00	661	2,880	0.230 *		

\* - Denotes critical movement

**Project Title:** BCHD-HLC  
**Intersection:** 8 - Hawthorne BI & 190th St  
**Description:** Future Base (2032)

Thru Lane: 1600 vph  
 Left Lane: 1600 vph  
 Double Lt Penalty: 10 %  
 ITS: 0 %

N-S Split Phase : N  
 E-W Split Phase : N  
 Lost Time (% of cycle) : 10  
 V/C Round Off (decs.) : 3

OLA Movements :  
 FF Movements:

**Date/Time:** AM PEAK HOUR

APPROACH	MVMT	LANES	VOLUME	CAPACITY	V/C	ICU ANALYSIS	
Southbound	RT	1.00	182	1,600	0.082	N-S(1):	0.333
	TH	4.00	2,137	6,400	0.334 *	N-S(2):	0.394 *
	LT	2.00	92	2,880	0.032	E-W(1):	0.371 *
Westbound	RT	1.00	163	1,600	0.086	E-W(2):	0.297
	TH	2.00	749	3,200	0.234	V/C:	0.765
	LT	2.00	277	2,880	0.096 *	Lost Time:	0.100
Northbound	RT	1.00	210	1,600	0.083	ITS:	0.000
	TH	4.00	1,925	6,400	0.301	ICU:	0.865
	LT	2.00	174	2,880	0.060 *	LOS:	D
Eastbound	RT	1.00	249	1,600	0.125		
	TH	2.00	881	3,200	0.275 *		
	LT	2.00	181	2,880	0.063		

**Date/Time:** PM PEAK HOUR

APPROACH	MVMT	LANES	VOLUME	CAPACITY	V/C	ICU ANALYSIS	
Southbound	RT	1.00	198	1,600	0.098	N-S(1):	0.402 *
	TH	4.00	1,745	6,400	0.273	N-S(2):	0.380
	LT	2.00	175	2,880	0.061 *	E-W(1):	0.358 *
Westbound	RT	1.00	166	1,600	0.073	E-W(2):	0.334
	TH	2.00	907	3,200	0.283	V/C:	0.760
	LT	2.00	324	2,880	0.113 *	Lost Time:	0.100
Northbound	RT	1.00	415	1,600	0.203	ITS:	0.000
	TH	4.00	2,182	6,400	0.341 *	ICU:	0.860
	LT	2.00	309	2,880	0.107	LOS:	D
Eastbound	RT	1.00	321	1,600	0.147		
	TH	2.00	784	3,200	0.245 *		
	LT	2.00	147	2,880	0.051		

\* - Denotes critical movement



**Project Title: BCHD-HLC**  
**Intersection: 9 - Prospect Av & Beryl St**  
**Description: Future Base (2032)**

Thru Lane: 1600 vph  
 Left Lane: 1600 vph  
 Double Lt Penalty: 10 %  
 ITS: 0 %

N-S Split Phase : N  
 E-W Split Phase : N  
 Lost Time (% of cycle) : 10  
 V/C Round Off (decs.) : 3

OLA Movements :  
 FF Movements:

**Date/Time: AM PEAK HOUR**

APPROACH	MVMT	LANES	VOLUME	CAPACITY	V/C	ICU ANALYSIS
Southbound	RT	0.00	116	0	0.000	N-S(1): 0.338 *
	TH	2.00	496	3,200	0.191	N-S(2): 0.231
	LT	1.00	16	1,600	0.010 *	E-W(1): 0.394 *
Westbound	RT	1.00	17	1,600	0.006	E-W(2): 0.305
	TH	1.00	389	1,600	0.243	
	LT	1.00	388	1,600	0.243 *	V/C: 0.732
Northbound	RT	0.00	309	0	0.000	Lost Time: 0.100
	TH	2.00	741	3,200	0.328 *	ITS: 0.000
	LT	1.00	64	1,600	0.040	
Eastbound	RT	0.00	55	0	0.000	ICU: 0.832
	TH	2.00	427	3,200	0.151 *	
	LT	1.00	99	1,600	0.062	LOS: D

**Date/Time: PM PEAK HOUR**

APPROACH	MVMT	LANES	VOLUME	CAPACITY	V/C	ICU ANALYSIS
Southbound	RT	0.00	57	0	0.000	N-S(1): 0.274
	TH	2.00	712	3,200	0.240 *	N-S(2): 0.299 *
	LT	1.00	39	1,600	0.024	E-W(1): 0.315 *
Westbound	RT	1.00	31	1,600	0.007	E-W(2): 0.209
	TH	1.00	298	1,600	0.186	
	LT	1.00	302	1,600	0.189 *	V/C: 0.614
Northbound	RT	0.00	293	0	0.000	Lost Time: 0.100
	TH	2.00	508	3,200	0.250	ITS: 0.000
	LT	1.00	94	1,600	0.059 *	
Eastbound	RT	0.00	46	0	0.000	ICU: 0.714
	TH	2.00	356	3,200	0.126 *	
	LT	1.00	37	1,600	0.023	LOS: C

\* - Denotes critical movement

**Project Title: BCHD-HLC**  
**Intersection: 13 - Prospect Av & Middle Campus Driveway**  
**Description: Future Base (2032)**

Thru Lane: 1600 vph	N-S Split Phase : N
Left Lane: 1600 vph	E-W Split Phase : N
Double Lt Penalty: 10 %	Lost Time (% of cycle) : 10
ITS: 0 %	V/C Round Off (decs.) : 3
OLA Movements :	
FF Movements:	

**Date/Time: AM PEAK HOUR**

APPROACH	MVMT	LANES	VOLUME	CAPACITY	V/C	ICU ANALYSIS
Southbound	RT	0.20	0	320	0.000	N-S(1): 0.466
	TH	0.80	801	1,280	0.626 *	N-S(2): 0.626 *
	LT	1.00	144	1,600	0.090	E-W(1): 0.074 *
Westbound	RT	1.00	27	1,600	0.000	E-W(2): 0.000
	TH	0.00	0	0	0.000	
	LT	1.00	119	1,600	0.074 *	V/C: 0.700
Northbound	RT	0.00	96	0	0.000	Lost Time: 0.100
	TH	2.00	1,106	3,200	0.376	ITS: 0.000
	LT	1.00	0	1,600	0.000 *	
Eastbound	RT	0.00	0	0	0.000	ICU: 0.800
	TH	1.00	0	1,600	0.000 *	
	LT	0.00	0	0	0.000	LOS: C

**Date/Time: PM PEAK HOUR**

APPROACH	MVMT	LANES	VOLUME	CAPACITY	V/C	ICU ANALYSIS
Southbound	RT	0.00	0	0	0.000	N-S(1): 0.298
	TH	2.00	1,037	3,200	0.324 *	N-S(2): 0.325 *
	LT	1.00	64	1,600	0.040	E-W(1): 0.074 *
Westbound	RT	1.00	93	1,600	0.038	E-W(2): 0.038
	TH	0.00	0	0	0.000	
	LT	1.00	119	1,600	0.074 *	V/C: 0.399
Northbound	RT	0.00	32	0	0.000	Lost Time: 0.100
	TH	2.00	795	3,200	0.258	ITS: 0.000
	LT	1.00	2	1,600	0.001 *	
Eastbound	RT	0.00	0	0	0.000	ICU: 0.499
	TH	1.00	0	1,600	0.000 *	
	LT	0.00	0	0	0.000	LOS: A

\* - Denotes critical movement

**Project Title: BCHD-HLC**  
**Intersection: 15 - Prospect Av & Diamond St**  
**Description: Future Base (2032)**

Thru Lane: 1600 vph  
 Left Lane: 1600 vph  
 Double Lt Penalty: 10 %  
 ITS: 0 %

N-S Split Phase : N  
 E-W Split Phase : N  
 Lost Time (% of cycle) : 10  
 V/C Round Off (decs.) : 3

OLA Movements :  
 FF Movements:

**Date/Time: AM PEAK HOUR**

APPROACH	MVMT	LANES	VOLUME	CAPACITY	V/C	ICU ANALYSIS	
Southbound	RT	0.00	198	0	0.000	N-S(1):	0.362 *
	TH	2.00	634	3,200	0.260	N-S(2):	0.298
	LT	1.00	7	1,600	0.004 *	E-W(1):	0.066
Westbound	RT	1.00	3	1,600	0.000	E-W(2):	0.072 *
	TH	1.00	0	1,600	0.000 *	V/C:	0.434
	LT	1.00	1	1,600	0.001	Lost Time:	0.100
Northbound	RT	0.00	0	0	0.000	ITS:	0.000
	TH	2.00	1,144	3,200	0.358 *	ICU:	0.534
	LT	1.00	61	1,600	0.038	LOS:	A
Eastbound	RT	0.00	69	0	0.000		
	TH	0.66	0	1,062	0.065		
	LT	1.34	139	1,925	0.072 *		

**Date/Time: PM PEAK HOUR**

APPROACH	MVMT	LANES	VOLUME	CAPACITY	V/C	ICU ANALYSIS	
Southbound	RT	0.00	68	0	0.000	N-S(1):	0.248
	TH	2.00	1,075	3,200	0.357 *	N-S(2):	0.363 *
	LT	1.00	13	1,600	0.008	E-W(1):	0.025
Westbound	RT	1.00	2	1,600	0.001 *	E-W(2):	0.029 *
	TH	1.00	0	1,600	0.000	V/C:	0.392
	LT	1.00	0	1,600	0.000	Lost Time:	0.100
Northbound	RT	0.00	3	0	0.000	ITS:	0.000
	TH	2.00	766	3,200	0.240	ICU:	0.492
	LT	1.00	9	1,600	0.006 *	LOS:	A
Eastbound	RT	0.00	23	0	0.000		
	TH	0.58	0	920	0.025		
	LT	1.43	57	2,052	0.028 *		

\* - Denotes critical movement

**Project Title:** BCHD-HLC  
**Intersection:** 16 - Hallison St & Anza Av  
**Description:** Future Base (2032)

Thru Lane: 1600 vph  
 Left Lane: 1600 vph  
 Double Lt Penalty: 10 %  
 ITS: 0 %

N-S Split Phase : N  
 E-W Split Phase : N  
 Lost Time (% of cycle) : 10  
 V/C Round Off (decs.) : 3

OLA Movements :  
 FF Movements:

**Date/Time:** AM PEAK HOUR

APPROACH	MVMT	LANES	VOLUME	CAPACITY	V/C	ICU ANALYSIS	
Southbound	RT	0.00	23	0	0.000	N-S(1):	0.360 *
	TH	2.00	971	3,200	0.311	N-S(2):	0.328
	LT	1.00	30	1,600	0.019 *	E-W(1):	0.145
Westbound	RT	0.00	48	0	0.000	E-W(2):	0.147 *
	TH	1.00	61	1,600	0.106 *	V/C:	0.507
	LT	0.00	61	1,600	0.038	Lost Time:	0.100
Northbound	RT	0.00	26	0	0.000	ITS:	0.000
	TH	2.00	1,065	3,200	0.341 *	ICU:	0.607
	LT	1.00	27	1,600	0.017	LOS:	B
Eastbound	RT	0.00	62	0	0.000		
	TH	1.00	43	1,600	0.107		
	LT	0.00	66	1,600	0.041 *		

**Date/Time:** PM PEAK HOUR

APPROACH	MVMT	LANES	VOLUME	CAPACITY	V/C	ICU ANALYSIS	
Southbound	RT	0.00	37	0	0.000	N-S(1):	0.423 *
	TH	2.00	1,193	3,200	0.384	N-S(2):	0.408
	LT	1.00	30	1,600	0.019 *	E-W(1):	0.051
Westbound	RT	0.00	37	0	0.000	E-W(2):	0.075 *
	TH	1.00	31	1,600	0.063 *	V/C:	0.498
	LT	0.00	33	1,600	0.021	Lost Time:	0.100
Northbound	RT	0.00	31	0	0.000	ITS:	0.000
	TH	2.00	1,262	3,200	0.404 *	ICU:	0.598
	LT	1.00	39	1,600	0.024	LOS:	A
Eastbound	RT	0.00	13	0	0.000		
	TH	1.00	16	1,600	0.030		
	LT	0.00	19	1,600	0.012 *		

\* - Denotes critical movement

**Project Title:** BCHD-HLC  
**Intersection:** 17 - Prospect Av & Del Amo Bl  
**Description:** Future Base (2032)

Thru Lane: 1600 vph  
 Left Lane: 1600 vph  
 Double Lt Penalty: 10 %  
 ITS: 0 %

N-S Split Phase : N  
 E-W Split Phase : N  
 Lost Time (% of cycle) : 10  
 V/C Round Off (decs.) : 3

OLA Movements :  
 FF Movements:

**Date/Time:** AM PEAK HOUR

APPROACH	MVMT	LANES	VOLUME	CAPACITY	V/C	ICU ANALYSIS	
Southbound	RT	0.00	39	0	0.000	N-S(1):	0.432 *
	TH	2.00	584	3,200	0.195	N-S(2):	0.284
	LT	1.00	70	1,600	0.044 *	E-W(1):	0.314 *
Westbound	RT	1.00	276	1,600	0.151	E-W(2):	0.189
	TH	1.00	266	1,600	0.166	V/C:	0.746
	LT	1.00	277	1,600	0.173 *	Lost Time:	0.100
Northbound	RT	0.00	358	0	0.000	ITS:	0.000
	TH	2.00	884	3,200	0.388 *	ICU:	0.846
	LT	1.00	142	1,600	0.089	LOS:	D
Eastbound	RT	1.00	151	1,600	0.050		
	TH	1.00	225	1,600	0.141 *		
	LT	1.00	36	1,600	0.023		

**Date/Time:** PM PEAK HOUR

APPROACH	MVMT	LANES	VOLUME	CAPACITY	V/C	ICU ANALYSIS	
Southbound	RT	0.00	5	0	0.000	N-S(1):	0.390 *
	TH	2.00	901	3,200	0.283	N-S(2):	0.344
	LT	1.00	193	1,600	0.121 *	E-W(1):	0.315 *
Westbound	RT	1.00	212	1,600	0.072	E-W(2):	0.127
	TH	1.00	186	1,600	0.116	V/C:	0.705
	LT	1.00	331	1,600	0.207 *	Lost Time:	0.100
Northbound	RT	0.00	300	0	0.000	ITS:	0.000
	TH	2.00	562	3,200	0.269 *	ICU:	0.805
	LT	1.00	97	1,600	0.061	LOS:	D
Eastbound	RT	1.00	140	1,600	0.057		
	TH	1.00	172	1,600	0.108 *		
	LT	1.00	17	1,600	0.011		

\* - Denotes critical movement

**Project Title:** BCHD-HLC  
**Intersection:** 19 - Wayne Av & Del Amo BI  
**Description:** Future Base (2032)

Thru Lane: 1600 vph  
 Left Lane: 1600 vph  
 Double Lt Penalty: 10 %  
 ITS: 0 %

N-S Split Phase : N  
 E-W Split Phase : N  
 Lost Time (% of cycle) : 10  
 V/C Round Off (decs.) : 3

OLA Movements :  
 FF Movements:

**Date/Time:** AM PEAK HOUR

APPROACH	MVMT	LANES	VOLUME	CAPACITY	V/C	ICU ANALYSIS	
Southbound	RT	0.00	34	0	0.000	N-S(1):	0.116 *
	TH	1.00	30	1,600	0.063	N-S(2):	0.094
	LT	0.00	36	1,600	0.023 *	E-W(1):	0.227
Westbound	RT	0.00	15	0	0.000	E-W(2):	0.253 *
	TH	2.00	773	3,200	0.246 *	V/C:	0.369
	LT	1.00	20	1,600	0.013	Lost Time:	0.100
Northbound	RT	0.00	80	0	0.000	ITS:	0.000
	TH	1.00	19	1,600	0.093 *	ICU:	0.469
	LT	0.00	50	1,600	0.031	LOS:	A
Eastbound	RT	0.00	6	0	0.000		
	TH	2.00	680	3,200	0.214		
	LT	1.00	11	1,600	0.007 *		

**Date/Time:** PM PEAK HOUR

APPROACH	MVMT	LANES	VOLUME	CAPACITY	V/C	ICU ANALYSIS	
Southbound	RT	0.00	7	0	0.000	N-S(1):	0.049 *
	TH	1.00	9	1,600	0.028	N-S(2):	0.032
	LT	0.00	28	1,600	0.018 *	E-W(1):	0.254
Westbound	RT	0.00	23	0	0.000	E-W(2):	0.262 *
	TH	2.00	793	3,200	0.255 *	V/C:	0.311
	LT	1.00	32	1,600	0.020	Lost Time:	0.100
Northbound	RT	0.00	38	0	0.000	ITS:	0.000
	TH	1.00	5	1,600	0.031 *	ICU:	0.411
	LT	0.00	7	1,600	0.004	LOS:	A
Eastbound	RT	0.00	7	0	0.000		
	TH	2.00	742	3,200	0.234		
	LT	1.00	11	1,600	0.007 *		

\* - Denotes critical movement

**Project Title:** BCHD-HLC  
**Intersection:** 20 - Henrietta St & Del Amo Bl  
**Description:** Future Base (2032)

Thru Lane: 1600 vph  
 Left Lane: 1600 vph  
 Double Lt Penalty: 10 %  
 ITS: 0 %

N-S Split Phase : N  
 E-W Split Phase : N  
 Lost Time (% of cycle) : 10  
 V/C Round Off (decs.) : 3

OLA Movements :  
 FF Movements:

**Date/Time:** AM PEAK HOUR

APPROACH	MVMT	LANES	VOLUME	CAPACITY	V/C	ICU ANALYSIS
Southbound	RT	0.00	0	0	0.000	N-S(1): 0.048
	TH	0.00	0	0	0.000 *	N-S(2): 0.080 *
	LT	0.00	0	0	0.000	E-W(1): 0.355 *
Westbound	RT	0.00	0	0	0.000	E-W(2): 0.217
	TH	2.00	695	3,200	0.217	V/C: 0.435
	LT	1.00	169	1,600	0.106 *	Lost Time: 0.100
Northbound	RT	1.00	161	1,600	0.048	ITS: 0.000
	TH	0.00	0	0	0.000	
	LT	1.00	128	1,600	0.080 *	
Eastbound	RT	0.00	45	0	0.000	ICU: 0.535
	TH	2.00	753	3,200	0.249 *	
	LT	0.00	0	0	0.000	LOS: A

**Date/Time:** PM PEAK HOUR

APPROACH	MVMT	LANES	VOLUME	CAPACITY	V/C	ICU ANALYSIS
Southbound	RT	0.00	0	0	0.000	N-S(1): 0.036
	TH	0.00	0	0	0.000 *	N-S(2): 0.048 *
	LT	0.00	0	0	0.000	E-W(1): 0.344 *
Westbound	RT	0.00	0	0	0.000	E-W(2): 0.240
	TH	2.00	769	3,200	0.240	V/C: 0.392
	LT	1.00	150	1,600	0.094 *	Lost Time: 0.100
Northbound	RT	1.00	132	1,600	0.036	ITS: 0.000
	TH	0.00	0	0	0.000	
	LT	1.00	77	1,600	0.048 *	
Eastbound	RT	0.00	79	0	0.000	ICU: 0.492
	TH	2.00	721	3,200	0.250 *	
	LT	0.00	0	0	0.000	LOS: A

\* - Denotes critical movement

**Project Title:** BCHD-HLC  
**Intersection:** 21 - Entradero Av & Del Amo Bl  
**Description:** Future Base (2032)

Thru Lane:	1600 vph	N-S Split Phase :	N
Left Lane:	1600 vph	E-W Split Phase :	N
Double Lt Penalty:	10 %	Lost Time (% of cycle) :	10
ITS:	0 %	V/C Round Off (decs.) :	3
OLA Movements :			
FF Movements:			

**Date/Time:** AM PEAK HOUR

APPROACH	MVMT	LANES	VOLUME	CAPACITY	V/C	ICU ANALYSIS
Southbound	RT	0.54	224	859	0.214	N-S(1): 0.261 *
	TH	0.00	0	0	0.000	N-S(2): 0.214
	LT	0.46	193	741	0.261 *	E-W(1): 0.229
Westbound	RT	0.00	185	0	0.000	E-W(2): 0.363 *
	TH	2.00	679	3,200	0.270 *	V/C: 0.624
	LT	0.00	0	0	0.000	Lost Time: 0.100
Northbound	RT	0.00	0	0	0.000	ITS: 0.000
	TH	0.00	0	0	0.000 *	
	LT	0.00	0	0	0.000	
Eastbound	RT	0.00	0	0	0.000	ICU: 0.724
	TH	2.00	733	3,200	0.229	
	LT	1.00	148	1,600	0.093 *	LOS: C

**Date/Time:** PM PEAK HOUR

APPROACH	MVMT	LANES	VOLUME	CAPACITY	V/C	ICU ANALYSIS
Southbound	RT	0.48	91	774	0.096	N-S(1): 0.118 *
	TH	0.00	0	0	0.000	N-S(2): 0.096
	LT	0.52	97	826	0.118 *	E-W(1): 0.243
Westbound	RT	0.00	95	0	0.000	E-W(2): 0.337 *
	TH	2.00	843	3,200	0.293 *	V/C: 0.455
	LT	0.00	0	0	0.000	Lost Time: 0.100
Northbound	RT	0.00	0	0	0.000	ITS: 0.000
	TH	0.00	0	0	0.000 *	
	LT	0.00	0	0	0.000	
Eastbound	RT	0.00	0	0	0.000	ICU: 0.555
	TH	2.00	778	3,200	0.243	
	LT	1.00	70	1,600	0.044 *	LOS: A

\* - Denotes critical movement



**Project Title:** BCHD-HLC  
**Intersection:** 22 - Victor St & Del Amo Bl  
**Description:** Future Base (2032)

Thru Lane: 1600 vph  
 Left Lane: 1600 vph  
 Double Lt Penalty: 10 %  
 ITS: 0 %

N-S Split Phase : N  
 E-W Split Phase : N  
 Lost Time (% of cycle) : 10  
 V/C Round Off (decs.) : 3

OLA Movements :  
 FF Movements:

**Date/Time:** AM PEAK HOUR

APPROACH	MVMT	LANES	VOLUME	CAPACITY	V/C	ICU ANALYSIS	
Southbound	RT	0.00	0	0	0.000	N-S(1):	0.103 *
	TH	0.00	0	0	0.000	N-S(2):	0.078
	LT	0.00	0	0	0.000 *	E-W(1):	0.368 *
Westbound	RT	0.00	0	0	0.000	E-W(2):	0.177
	TH	2.00	567	3,200	0.177	V/C:	0.471
	LT	1.00	137	1,600	0.086 *	Lost Time:	0.100
Northbound	RT	1.00	233	1,600	0.103 *	ITS:	0.000
	TH	0.00	0	0	0.000	ICU:	0.571
	LT	1.00	124	1,600	0.078	LOS:	A
Eastbound	RT	0.00	177	0	0.000		
	TH	2.00	726	3,200	0.282 *		
	LT	0.00	0	0	0.000		

**Date/Time:** PM PEAK HOUR

APPROACH	MVMT	LANES	VOLUME	CAPACITY	V/C	ICU ANALYSIS	
Southbound	RT	0.00	0	0	0.000	N-S(1):	0.038 *
	TH	0.00	0	0	0.000	N-S(2):	0.030
	LT	0.00	0	0	0.000 *	E-W(1):	0.317 *
Westbound	RT	0.00	0	0	0.000	E-W(2):	0.280
	TH	2.00	897	3,200	0.280	V/C:	0.355
	LT	1.00	71	1,600	0.044 *	Lost Time:	0.100
Northbound	RT	1.00	96	1,600	0.038 *	ITS:	0.000
	TH	0.00	0	0	0.000	ICU:	0.455
	LT	1.00	48	1,600	0.030	LOS:	A
Eastbound	RT	0.00	59	0	0.000		
	TH	2.00	814	3,200	0.273 *		
	LT	0.00	0	0	0.000		

\* - Denotes critical movement

**Project Title:** BCHD-HLC  
**Intersection:** 23 - Anza Av & Del Amo Bl  
**Description:** Future Base (2032)

Thru Lane: 1600 vph  
 Left Lane: 1600 vph  
 Double Lt Penalty: 10 %  
 ITS: 0 %

N-S Split Phase : N  
 E-W Split Phase : N  
 Lost Time (% of cycle) : 10  
 V/C Round Off (decs.) : 3

OLA Movements :  
 FF Movements:

**Date/Time:** AM PEAK HOUR

APPROACH	MVMT	LANES	VOLUME	CAPACITY	V/C	ICU ANALYSIS	
Southbound	RT	0.00	138	0	0.000	N-S(1):	0.357
	TH	2.00	772	3,200	0.284 *	N-S(2):	0.360 *
	LT	1.00	170	1,600	0.106	E-W(1):	0.343
Westbound	RT	0.00	136	0	0.000	E-W(2):	0.347 *
	TH	2.00	633	3,200	0.240 *	V/C:	0.707
	LT	1.00	147	1,600	0.092	Lost Time:	0.100
Northbound	RT	1.00	221	1,600	0.092	ITS:	0.000
	TH	2.00	802	3,200	0.251	ICU:	0.807
	LT	1.00	121	1,600	0.076 *	LOS:	D
Eastbound	RT	1.00	124	1,600	0.040		
	TH	2.00	802	3,200	0.251		
	LT	1.00	171	1,600	0.107 *		

**Date/Time:** PM PEAK HOUR

APPROACH	MVMT	LANES	VOLUME	CAPACITY	V/C	ICU ANALYSIS	
Southbound	RT	0.00	117	0	0.000	N-S(1):	0.393
	TH	2.00	1,014	3,200	0.353 *	N-S(2):	0.464 *
	LT	1.00	113	1,600	0.071	E-W(1):	0.332
Westbound	RT	0.00	171	0	0.000	E-W(2):	0.409 *
	TH	2.00	745	3,200	0.286 *	V/C:	0.873
	LT	1.00	230	1,600	0.144	Lost Time:	0.100
Northbound	RT	1.00	146	1,600	0.019	ITS:	0.000
	TH	2.00	1,031	3,200	0.322	ICU:	0.973
	LT	1.00	178	1,600	0.111 *	LOS:	E
Eastbound	RT	1.00	141	1,600	0.033		
	TH	2.00	600	3,200	0.188		
	LT	1.00	197	1,600	0.123 *		

\* - Denotes critical movement

**Project Title: BCHD-HLC**  
**Intersection: 24 - Hawthorne BI & Del Amo BI**  
**Description: Future Base (2032)**

Thru Lane: 1600 vph  
 Left Lane: 1600 vph  
 Double Lt Penalty: 10 %  
 ITS: 0 %

N-S Split Phase : N  
 E-W Split Phase : N  
 Lost Time (% of cycle) : 10  
 V/C Round Off (decs.) : 3

OLA Movements :  
 FF Movements:

**Date/Time: AM PEAK HOUR**

APPROACH	MVMT	LANES	VOLUME	CAPACITY	V/C	ICU ANALYSIS	
Southbound	RT	0.00	193	0	0.000	N-S(1):	0.380
	TH	4.00	2,165	6,400	0.368 *	N-S(2):	0.465 *
	LT	2.00	138	2,880	0.048	E-W(1):	0.368 *
Westbound	RT	1.00	87	1,600	0.030	E-W(2):	0.342
	TH	2.00	759	3,200	0.237	V/C:	0.833
	LT	2.00	244	2,880	0.085 *	Lost Time:	0.100
Northbound	RT	0.00	212	0	0.000	ITS:	0.000
	TH	4.00	1,915	6,400	0.332	ICU:	0.933
	LT	1.00	155	1,600	0.097 *	LOS:	E
Eastbound	RT	1.00	68	1,600	0.000		
	TH	2.00	907	3,200	0.283 *		
	LT	2.00	301	2,880	0.105		

**Date/Time: PM PEAK HOUR**

APPROACH	MVMT	LANES	VOLUME	CAPACITY	V/C	ICU ANALYSIS	
Southbound	RT	0.00	215	0	0.000	N-S(1):	0.415
	TH	4.00	2,064	6,400	0.356 *	N-S(2):	0.449 *
	LT	2.00	153	2,880	0.053	E-W(1):	0.324
Westbound	RT	1.00	202	1,600	0.100	E-W(2):	0.420 *
	TH	2.00	979	3,200	0.306 *	V/C:	0.869
	LT	2.00	300	2,880	0.104	Lost Time:	0.100
Northbound	RT	0.00	112	0	0.000	ITS:	0.000
	TH	4.00	2,207	6,400	0.362	ICU:	0.969
	LT	1.00	148	1,600	0.093 *	LOS:	E
Eastbound	RT	1.00	132	1,600	0.036		
	TH	2.00	703	3,200	0.220		
	LT	2.00	329	2,880	0.114 *		

\* - Denotes critical movement

**Project Title: BCHD-HLC**  
**Intersection: 25 - Prospect Av & Torrance Bl**  
**Description: Future Base (2032)**

Thru Lane: 1600 vph  
 Left Lane: 1600 vph  
 Double Lt Penalty: 10 %  
 ITS: 0 %

N-S Split Phase : N  
 E-W Split Phase : N  
 Lost Time (% of cycle) : 10  
 V/C Round Off (decs.) : 3

OLA Movements :  
 FF Movements:

**Date/Time: AM PEAK HOUR**

APPROACH	MVMT	LANES	VOLUME	CAPACITY	V/C	ICU ANALYSIS	
Southbound	RT	0.00	92	0	0.000	N-S(1):	0.409 *
	TH	2.00	586	3,200	0.212	N-S(2):	0.253
	LT	1.00	185	1,600	0.116 *	E-W(1):	0.200
Westbound	RT	0.00	182	0	0.000	E-W(2):	0.236 *
	TH	3.00	567	4,800	0.156 *	V/C:	0.645
	LT	1.00	130	1,600	0.081	Lost Time:	0.100
Northbound	RT	0.00	214	0	0.000	ITS:	0.000
	TH	2.00	725	3,200	0.293 *	ICU:	0.745
	LT	1.00	66	1,600	0.041	LOS:	C
Eastbound	RT	0.00	28	0	0.000		
	TH	3.00	541	4,800	0.119		
	LT	1.00	128	1,600	0.080 *		

**Date/Time: PM PEAK HOUR**

APPROACH	MVMT	LANES	VOLUME	CAPACITY	V/C	ICU ANALYSIS	
Southbound	RT	0.00	141	0	0.000	N-S(1):	0.392 *
	TH	2.00	854	3,200	0.311	N-S(2):	0.340
	LT	1.00	251	1,600	0.157 *	E-W(1):	0.239
Westbound	RT	0.00	204	0	0.000	E-W(2):	0.265 *
	TH	3.00	677	4,800	0.184 *	V/C:	0.657
	LT	1.00	164	1,600	0.103	Lost Time:	0.100
Northbound	RT	0.00	109	0	0.000	ITS:	0.000
	TH	2.00	643	3,200	0.235 *	ICU:	0.757
	LT	1.00	46	1,600	0.029	LOS:	C
Eastbound	RT	0.00	43	0	0.000		
	TH	3.00	608	4,800	0.136		
	LT	1.00	129	1,600	0.081 *		

\* - Denotes critical movement

Intersection	
Intersection Delay, s/veh	143
Intersection LOS	F

Movement	EBL	EBT	EBR	WBL	WBT	WBR	NBL	NBT	NBR	SBL	SBT	SBR
Lane Configurations		↔↔			↔↔		↗	↑	↖		↖	↗
Traffic Vol, veh/h	49	523	8	35	728	1	57	244	67	111	197	216
Future Vol, veh/h	49	523	8	35	728	1	57	244	67	111	197	216
Peak Hour Factor	0.90	0.90	0.90	0.90	0.90	0.90	0.90	0.90	0.90	0.90	0.90	0.90
Heavy Vehicles, %	2	2	2	2	2	2	2	2	2	2	2	2
Mvmt Flow	54	581	9	39	809	1	63	271	74	123	219	240
Number of Lanes	0	2	0	0	2	0	1	1	1	0	1	1

Approach	EB	WB	NB	SB
Opposing Approach	WB	EB	SB	NB
Opposing Lanes	2	2	2	3
Conflicting Approach Left	SB	NB	EB	WB
Conflicting Lanes Left	2	3	2	2
Conflicting Approach Right	NB	SB	WB	EB
Conflicting Lanes Right	3	2	2	2
HCM Control Delay	112.5	230.9	67	102.1
HCM LOS	F	F	F	F

Lane	NBLn1	NBLn2	NBLn3	EBLn1	EBLn2	WBLn1	WBLn2	SBLn1	SBLn2
Vol Left, %	100%	0%	0%	16%	0%	9%	0%	36%	0%
Vol Thru, %	0%	100%	0%	84%	97%	91%	100%	64%	0%
Vol Right, %	0%	0%	100%	0%	3%	0%	0%	0%	100%
Sign Control	Stop	Stop	Stop	Stop	Stop	Stop	Stop	Stop	Stop
Traffic Vol by Lane	57	244	67	311	270	399	365	308	216
LT Vol	57	0	0	49	0	35	0	111	0
Through Vol	0	244	0	262	262	364	364	197	0
RT Vol	0	0	67	0	8	0	1	0	216
Lane Flow Rate	63	271	74	345	299	443	406	342	240
Geometry Grp	8	8	8	8	8	8	8	8	8
Degree of Util (X)	0.233	0.959	0.249	1.141	0.983	1.465	1.324	1.16	0.755
Departure Headway (Hd)	15.579	15.053	14.316	12.888	12.783	12.488	12.44	13.202	12.271
Convergence, Y/N	Yes	Yes	Yes	Yes	Yes	Yes	Yes	Yes	Yes
Cap	232	244	252	283	287	297	296	277	298
Service Time	13.279	12.753	12.016	10.588	10.483	10.188	10.14	10.902	9.971
HCM Lane V/C Ratio	0.272	1.111	0.294	1.219	1.042	1.492	1.372	1.235	0.805
HCM Control Delay	22.9	89.7	21.7	134.6	87	258.3	200.9	142.4	44.7
HCM Lane LOS	C	F	C	F	F	F	F	F	E
HCM 95th-tile Q	0.9	8.7	1	13.7	9.9	23.5	19.2	14	5.7

**Intersection**

Intersection Delay, s/veh 132.9

Intersection LOS F

Movement	EBL	EBT	EBR	WBL	WBT	WBR	NBL	NBT	NBR	SBL	SBT	SBR
Lane Configurations	↖	↗		↖	↗			↕			↕	
Traffic Vol, veh/h	143	602	8	23	511	6	15	20	28	10	8	268
Future Vol, veh/h	143	602	8	23	511	6	15	20	28	10	8	268
Peak Hour Factor	0.85	0.85	0.85	0.85	0.85	0.85	0.85	0.85	0.85	0.85	0.85	0.85
Heavy Vehicles, %	2	2	2	2	2	2	2	2	2	2	2	2
Mvmt Flow	168	708	9	27	601	7	18	24	33	12	9	315
Number of Lanes	1	1	0	1	1	0	0	1	0	0	1	0

Approach	EB	WB	NB	SB
Opposing Approach	WB	EB	SB	NB
Opposing Lanes	2	2	1	1
Conflicting Approach Left	SB	NB	EB	WB
Conflicting Lanes Left	1	1	2	2
Conflicting Approach Right	NB	SB	WB	EB
Conflicting Lanes Right	1	1	2	2
HCM Control Delay	180.9	137.5	14.7	23.8
HCM LOS	F	F	B	C

Lane	NBLn1	EBLn1	EBLn2	WBLn1	WBLn2	SBLn1
Vol Left, %	24%	100%	0%	100%	0%	3%
Vol Thru, %	32%	0%	99%	0%	99%	3%
Vol Right, %	44%	0%	1%	0%	1%	94%
Sign Control	Stop	Stop	Stop	Stop	Stop	Stop
Traffic Vol by Lane	63	143	610	23	517	286
LT Vol	15	143	0	23	0	10
Through Vol	20	0	602	0	511	8
RT Vol	28	0	8	0	6	268
Lane Flow Rate	74	168	718	27	608	336
Geometry Grp	2	7	7	7	7	2
Degree of Util (X)	0.174	0.356	1.415	0.058	1.223	0.645
Departure Headway (Hd)	9.706	8.038	7.513	8.309	7.784	7.749
Convergence, Y/N	Yes	Yes	Yes	Yes	Yes	Yes
Cap	372	451	488	434	474	471
Service Time	7.706	5.738	5.213	6.009	5.484	5.749
HCM Lane V/C Ratio	0.199	0.373	1.471	0.062	1.283	0.713
HCM Control Delay	14.7	15.1	219.8	11.5	143.1	23.8
HCM Lane LOS	B	C	F	B	F	C
HCM 95th-tile Q	0.6	1.6	32.6	0.2	22.4	4.5

Intersection

Intersection Delay, s/veh 92.7

Intersection LOS F

Movement	EBL	EBT	EBR	WBL	WBT	WBR	NBL	NBT	NBR	SBL	SBT	SBR
Lane Configurations												
Traffic Vol, veh/h	141	467	42	10	375	9	16	165	50	9	74	139
Future Vol, veh/h	141	467	42	10	375	9	16	165	50	9	74	139
Peak Hour Factor	0.85	0.85	0.85	0.85	0.85	0.85	0.85	0.85	0.85	0.85	0.85	0.85
Heavy Vehicles, %	2	2	2	2	2	2	2	2	2	2	2	2
Mvmt Flow	166	549	49	12	441	11	19	194	59	11	87	164
Number of Lanes	1	1	0	0	1	0	0	1	0	0	1	1

Approach	EB	WB	NB	SB
Opposing Approach	WB	EB	SB	NB
Opposing Lanes	1	2	2	1
Conflicting Approach Left SB		NB	EB	WB
Conflicting Lanes Left	2	1	2	1
Conflicting Approach Right NB		SB	WB	EB
Conflicting Lanes Right	1	2	1	2
HCM Control Delay	143.5	88.6	30.1	16.6
HCM LOS	F	F	D	C

Lane	NBLn1	EBLn1	EBLn2	WBLn1	SBLn1	SBLn2
Vol Left, %	7%	100%	0%	3%	11%	0%
Vol Thru, %	71%	0%	92%	95%	89%	0%
Vol Right, %	22%	0%	8%	2%	0%	100%
Sign Control	Stop	Stop	Stop	Stop	Stop	Stop
Traffic Vol by Lane	231	141	509	394	83	139
LT Vol	16	141	0	10	9	0
Through Vol	165	0	467	375	74	0
RT Vol	50	0	42	9	0	139
Lane Flow Rate	272	166	599	464	98	164
Geometry Grp	6	7	7	6	7	7
Degree of Util (X)	0.67	0.389	1.309	1.052	0.247	0.379
Departure Headway (Hd)	9.603	8.745	8.167	8.698	9.781	8.99
Convergence, Y/N	Yes	Yes	Yes	Yes	Yes	Yes
Cap	378	415	449	422	369	402
Service Time	7.603	6.445	5.867	6.698	7.481	6.69
HCM Lane V/C Ratio	0.72	0.4	1.334	1.1	0.266	0.408
HCM Control Delay	30.1	16.9	178.6	88.6	15.7	17.1
HCM Lane LOS	D	C	F	F	C	C
HCM 95th-tile Q	4.7	1.8	25.5	14.2	1	1.7

HCM 6th TWSC  
12: Prospect Av & BCHD North Driveway

02/22/2021

Intersection						
Int Delay, s/veh	0.1					
Movement	WBL	WBR	NBT	NBR	SBL	SBT
Lane Configurations		↗	↕			↕
Traffic Vol, veh/h	0	19	1133	7	0	942
Future Vol, veh/h	0	19	1133	7	0	942
Conflicting Peds, #/hr	0	0	0	0	0	0
Sign Control	Stop	Stop	Free	Free	Free	Free
RT Channelized	-	None	-	None	-	None
Storage Length	-	0	-	-	-	-
Veh in Median Storage, #	0	-	0	-	-	0
Grade, %	0	-	0	-	-	0
Peak Hour Factor	85	85	85	85	85	85
Heavy Vehicles, %	2	2	2	2	2	2
Mvmt Flow	0	22	1333	8	0	1108

Major/Minor	Minor1	Major1	Major2			
Conflicting Flow All	-	671	0	0	-	-
Stage 1	-	-	-	-	-	-
Stage 2	-	-	-	-	-	-
Critical Hdwy	-	6.94	-	-	-	-
Critical Hdwy Stg 1	-	-	-	-	-	-
Critical Hdwy Stg 2	-	-	-	-	-	-
Follow-up Hdwy	-	3.32	-	-	-	-
Pot Cap-1 Maneuver	0	399	-	-	0	-
Stage 1	0	-	-	-	0	-
Stage 2	0	-	-	-	0	-
Platoon blocked, %			-	-		-
Mov Cap-1 Maneuver	-	399	-	-	-	-
Mov Cap-2 Maneuver	-	-	-	-	-	-
Stage 1	-	-	-	-	-	-
Stage 2	-	-	-	-	-	-

Approach	WB	NB	SB
HCM Control Delay, s	14.6	0	0
HCM LOS	B		

Minor Lane/Major Mvmt	NBT	NBRWBLn1	SBT
Capacity (veh/h)	-	-	399
HCM Lane V/C Ratio	-	-	0.056
HCM Control Delay (s)	-	-	14.6
HCM Lane LOS	-	-	B
HCM 95th %tile Q(veh)	-	-	0.2



HCM 6th TWSC  
 14: BCHD South Driveway & Prospect Av

02/22/2021

Intersection						
Int Delay, s/veh	0.1					
Movement	WBL	WBR	NBT	NBR	SBL	SBT
Lane Configurations		↗	↕			↕
Traffic Vol, veh/h	0	15	1194	91	0	838
Future Vol, veh/h	0	15	1194	91	0	838
Conflicting Peds, #/hr	0	0	0	0	0	0
Sign Control	Stop	Stop	Free	Free	Free	Free
RT Channelized	-	None	-	None	-	None
Storage Length	-	0	-	-	-	-
Veh in Median Storage, #	0	-	0	-	-	0
Grade, %	0	-	0	-	-	0
Peak Hour Factor	85	85	85	85	85	85
Heavy Vehicles, %	2	2	2	2	2	2
Mvmt Flow	0	18	1405	107	0	986

Major/Minor	Minor1	Major1	Major2		
Conflicting Flow All	-	756	0	0	-
Stage 1	-	-	-	-	-
Stage 2	-	-	-	-	-
Critical Hdwy	-	6.94	-	-	-
Critical Hdwy Stg 1	-	-	-	-	-
Critical Hdwy Stg 2	-	-	-	-	-
Follow-up Hdwy	-	3.32	-	-	-
Pot Cap-1 Maneuver	0	351	-	-	0
Stage 1	0	-	-	-	0
Stage 2	0	-	-	-	0
Platoon blocked, %			-	-	-
Mov Cap-1 Maneuver	-	351	-	-	-
Mov Cap-2 Maneuver	-	-	-	-	-
Stage 1	-	-	-	-	-
Stage 2	-	-	-	-	-

Approach	WB	NB	SB
HCM Control Delay, s	15.8	0	0
HCM LOS	C		

Minor Lane/Major Mvmt	NBT	NBRWBLn1	SBT
Capacity (veh/h)	-	-	351
HCM Lane V/C Ratio	-	-	0.05
HCM Control Delay (s)	-	-	15.8
HCM Lane LOS	-	-	C
HCM 95th %tile Q(veh)	-	-	0.2

Intersection						
Int Delay, s/veh	7.1					
Movement	EBL	EBT	WBT	WBR	SBL	SBR
Lane Configurations	↖	↕	↕		↖	↖
Traffic Vol, veh/h	53	607	783	112	68	47
Future Vol, veh/h	53	607	783	112	68	47
Conflicting Peds, #/hr	0	0	0	0	0	0
Sign Control	Free	Free	Free	Free	Stop	Stop
RT Channelized	-	None	-	None	-	None
Storage Length	100	-	-	-	0	50
Veh in Median Storage, #	-	0	0	-	0	-
Grade, %	-	0	0	-	0	-
Peak Hour Factor	80	80	80	80	80	80
Heavy Vehicles, %	2	2	2	2	2	2
Mvmt Flow	66	759	979	140	85	59

Major/Minor	Major1	Major2	Minor2		
Conflicting Flow All	1119	0	-	0	1561 560
Stage 1	-	-	-	-	1049 -
Stage 2	-	-	-	-	512 -
Critical Hdwy	4.14	-	-	-	6.84 6.94
Critical Hdwy Stg 1	-	-	-	-	5.84 -
Critical Hdwy Stg 2	-	-	-	-	5.84 -
Follow-up Hdwy	2.22	-	-	-	3.52 3.32
Pot Cap-1 Maneuver	620	-	-	-	103 472
Stage 1	-	-	-	-	298 -
Stage 2	-	-	-	-	567 -
Platoon blocked, %		-	-	-	
Mov Cap-1 Maneuver	620	-	-	-	92 472
Mov Cap-2 Maneuver	-	-	-	-	92 -
Stage 1	-	-	-	-	266 -
Stage 2	-	-	-	-	567 -

Approach	EB	WB	SB
HCM Control Delay, s	0.9	0	97.7
HCM LOS			F

Minor Lane/Major Mvmt	EBL	EBT	WBT	WBR	SBLn1	SBLn2
Capacity (veh/h)	620	-	-	-	92	472
HCM Lane V/C Ratio	0.107	-	-	-	0.924	0.124
HCM Control Delay (s)	11.5	-	-	-	155.7	13.7
HCM Lane LOS	B	-	-	-	F	B
HCM 95th %tile Q(veh)	0.4	-	-	-	5.2	0.4

Intersection	
Intersection Delay, s/veh	82
Intersection LOS	F

Movement	EBL	EBT	EBR	WBL	WBT	WBR	NBL	NBT	NBR	SBL	SBT	SBR
Lane Configurations		↔↔			↔↔		↔	↑	↔		↔	↔
Traffic Vol, veh/h	80	597	23	41	594	0	26	139	47	136	164	126
Future Vol, veh/h	80	597	23	41	594	0	26	139	47	136	164	126
Peak Hour Factor	0.95	0.95	0.95	0.95	0.95	0.95	0.95	0.95	0.95	0.95	0.95	0.95
Heavy Vehicles, %	2	2	2	2	2	2	2	2	2	2	2	2
Mvmt Flow	84	628	24	43	625	0	27	146	49	143	173	133
Number of Lanes	0	2	0	0	2	0	1	1	1	0	1	1

Approach	EB	WB	NB	SB
Opposing Approach	WB	EB	SB	NB
Opposing Lanes	2	2	2	3
Conflicting Approach Left	SB	NB	EB	WB
Conflicting Lanes Left	2	3	2	2
Conflicting Approach Right	NB	SB	WB	EB
Conflicting Lanes Right	3	2	2	2
HCM Control Delay	97.3	102.3	22.5	56.4
HCM LOS	F	F	C	F

Lane	NBLn1	NBLn2	NBLn3	EBLn1	EBLn2	WBLn1	WBLn2	SBLn1	SBLn2
Vol Left, %	100%	0%	0%	21%	0%	17%	0%	45%	0%
Vol Thru, %	0%	100%	0%	79%	93%	83%	100%	55%	0%
Vol Right, %	0%	0%	100%	0%	7%	0%	0%	0%	100%
Sign Control	Stop	Stop	Stop	Stop	Stop	Stop	Stop	Stop	Stop
Traffic Vol by Lane	26	139	47	379	322	239	396	300	126
LT Vol	26	0	0	80	0	41	0	136	0
Through Vol	0	139	0	299	299	198	396	164	0
RT Vol	0	0	47	0	23	0	0	0	126
Lane Flow Rate	27	146	49	398	338	252	417	316	133
Geometry Grp	8	8	8	8	8	8	8	8	8
Degree of Util (X)	0.093	0.475	0.151	1.13	0.945	0.723	1.188	0.943	0.362
Departure Headway (Hd)	12.863	12.335	11.596	10.61	10.448	10.665	10.575	11.436	10.46
Convergence, Y/N	Yes	Yes	Yes	Yes	Yes	Yes	Yes	Yes	Yes
Cap	280	294	311	347	349	342	346	319	346
Service Time	10.563	10.035	9.296	8.31	8.148	8.365	8.275	9.136	8.16
HCM Lane V/C Ratio	0.096	0.497	0.158	1.147	0.968	0.737	1.205	0.991	0.384
HCM Control Delay	16.9	25.7	16.3	121.6	68.6	36.8	141.8	72.1	19
HCM Lane LOS	C	D	C	F	F	E	F	F	C
HCM 95th-tile Q	0.3	2.4	0.5	15.1	9.9	5.4	16.9	9.5	1.6

Intersection

Intersection Delay, s/veh67.7

Intersection LOS F

Movement	EBL	EBT	EBR	WBL	WBT	WBR	NBL	NBT	NBR	SBL	SBT	SBR
Lane Configurations	↖	↗		↖	↗			↕			↕	
Traffic Vol, veh/h	91	580	23	53	458	27	38	32	59	19	24	123
Future Vol, veh/h	91	580	23	53	458	27	38	32	59	19	24	123
Peak Hour Factor	0.95	0.95	0.95	0.95	0.95	0.95	0.95	0.95	0.95	0.95	0.95	0.95
Heavy Vehicles, %	2	2	2	2	2	2	2	2	2	2	2	2
Mvmt Flow	96	611	24	56	482	28	40	34	62	20	25	129
Number of Lanes	1	1	0	1	1	0	0	1	0	0	1	0

Approach	EB	WB	NB	SB
Opposing Approach	WB	EB	SB	NB
Opposing Lanes	2	2	1	1
Conflicting Approach Left SB		NB	EB	WB
Conflicting Lanes Left	1	1	2	2
Conflicting Approach Right NB		SB	WB	EB
Conflicting Lanes Right	1	1	2	2
HCM Control Delay	104.8	48.9	14.2	14.7
HCM LOS	F	E	B	B

Lane	NBLn1	EBLn1	EBLn2	WBLn1	WBLn2	SBLn1
Vol Left, %	29%	100%	0%	100%	0%	11%
Vol Thru, %	25%	0%	96%	0%	94%	14%
Vol Right, %	46%	0%	4%	0%	6%	74%
Sign Control	Stop	Stop	Stop	Stop	Stop	Stop
Traffic Vol by Lane	129	91	603	53	485	166
LT Vol	38	91	0	53	0	19
Through Vol	32	0	580	0	458	24
RT Vol	59	0	23	0	27	123
Lane Flow Rate	136	96	635	56	511	175
Geometry Grp	2	7	7	7	7	2
Degree of Util (X)	0.285	0.191	1.171	0.112	0.944	0.349
Departure Headway (Hd)	8.025	7.178	6.639	7.542	6.989	7.631
Convergence, Y/N	Yes	Yes	Yes	Yes	Yes	Yes
Cap	451	496	546	478	521	474
Service Time	6.025	4.973	4.433	5.242	4.689	5.631
HCM Lane V/C Ratio	0.302	0.194	1.163	0.117	0.981	0.369
HCM Control Delay	14.2	11.7	118.8	11.2	53	14.7
HCM Lane LOS	B	B	F	B	F	B
HCM 95th-tile Q	1.2	0.7	22.1	0.4	11.8	1.5

Intersection

Intersection Delay, s/veh 50.7

Intersection LOS F

Movement	EBL	EBT	EBR	WBL	WBT	WBR	NBL	NBT	NBR	SBL	SBT	SBR
Lane Configurations												
Traffic Vol, veh/h	114	522	59	19	407	10	22	44	18	23	81	96
Future Vol, veh/h	114	522	59	19	407	10	22	44	18	23	81	96
Peak Hour Factor	0.95	0.95	0.95	0.95	0.95	0.95	0.95	0.95	0.95	0.95	0.95	0.95
Heavy Vehicles, %	2	2	2	2	2	2	2	2	2	2	2	2
Mvmt Flow	120	549	62	20	428	11	23	46	19	24	85	101
Number of Lanes	1	1	0	0	1	0	0	1	0	0	1	1

Approach	EB	WB	NB	SB
Opposing Approach	WB	EB	SB	NB
Opposing Lanes	1	2	2	1
Conflicting Approach Left SB		NB	EB	WB
Conflicting Lanes Left	2	1	2	1
Conflicting Approach Right NB		SB	WB	EB
Conflicting Lanes Right	1	2	1	2
HCM Control Delay	74	37.9	13.8	12.8
HCM LOS	F	E	B	B

Lane	NBLn1	EBLn1	EBLn2	WBLn1	SBLn1	SBLn2
Vol Left, %	26%	100%	0%	4%	22%	0%
Vol Thru, %	52%	0%	90%	93%	78%	0%
Vol Right, %	21%	0%	10%	2%	0%	100%
Sign Control	Stop	Stop	Stop	Stop	Stop	Stop
Traffic Vol by Lane	84	114	581	436	104	96
LT Vol	22	114	0	19	23	0
Through Vol	44	0	522	407	81	0
RT Vol	18	0	59	10	0	96
Lane Flow Rate	88	120	612	459	109	101
Geometry Grp	6	7	7	6	7	7
Degree of Util (X)	0.202	0.232	1.081	0.852	0.242	0.201
Departure Headway (Hd)	8.622	6.948	6.366	6.897	8.275	7.437
Convergence, Y/N	Yes	Yes	Yes	Yes	Yes	Yes
Cap	419	515	569	528	437	486
Service Time	6.622	4.719	4.137	4.897	5.975	5.137
HCM Lane V/C Ratio	0.21	0.233	1.076	0.869	0.249	0.208
HCM Control Delay	13.8	11.8	86.2	37.9	13.6	12
HCM Lane LOS	B	B	F	E	B	B
HCM 95th-tile Q	0.7	0.9	18.2	9	0.9	0.7

HCM 6th TWSC  
 12: Prospect Av & BCHD North Driveway

02/19/2021

Intersection						
Int Delay, s/veh	0.4					
Movement	WBL	WBR	NBT	NBR	SBL	SBT
Lane Configurations		↗	↕			↕
Traffic Vol, veh/h	0	58	905	0	0	1091
Future Vol, veh/h	0	58	905	0	0	1091
Conflicting Peds, #/hr	0	0	0	0	0	0
Sign Control	Stop	Stop	Free	Free	Free	Free
RT Channelized	-	None	-	None	-	None
Storage Length	-	0	-	-	-	-
Veh in Median Storage, #	0	-	0	-	-	0
Grade, %	0	-	0	-	-	0
Peak Hour Factor	95	95	95	95	95	95
Heavy Vehicles, %	2	2	2	2	2	2
Mvmt Flow	0	61	953	0	0	1148

Major/Minor	Minor1	Major1	Major2		
Conflicting Flow All	-	477	0	0	-
Stage 1	-	-	-	-	-
Stage 2	-	-	-	-	-
Critical Hdwy	-	6.94	-	-	-
Critical Hdwy Stg 1	-	-	-	-	-
Critical Hdwy Stg 2	-	-	-	-	-
Follow-up Hdwy	-	3.32	-	-	-
Pot Cap-1 Maneuver	0	534	-	-	0
Stage 1	0	-	-	-	0
Stage 2	0	-	-	-	0
Platoon blocked, %			-	-	-
Mov Cap-1 Maneuver	-	534	-	-	-
Mov Cap-2 Maneuver	-	-	-	-	-
Stage 1	-	-	-	-	-
Stage 2	-	-	-	-	-

Approach	WB	NB	SB
HCM Control Delay, s	12.6	0	0
HCM LOS	B		

Minor Lane/Major Mvmt	NBT	NBRWBLn1	SBT
Capacity (veh/h)	-	-	534
HCM Lane V/C Ratio	-	-	0.114
HCM Control Delay (s)	-	-	12.6
HCM Lane LOS	-	-	B
HCM 95th %tile Q(veh)	-	-	0.4

HCM 6th TWSC  
 14: BCHD South Driveway & Prospect Av

02/19/2021

Intersection						
Int Delay, s/veh	0.3					
Movement	WBL	WBR	NBT	NBR	SBL	SBT
Lane Configurations		↗	↕			↕
Traffic Vol, veh/h	0	44	795	38	0	1150
Future Vol, veh/h	0	44	795	38	0	1150
Conflicting Peds, #/hr	0	0	0	0	0	0
Sign Control	Stop	Stop	Free	Free	Free	Free
RT Channelized	-	None	-	None	-	None
Storage Length	-	0	-	-	-	-
Veh in Median Storage, #	0	-	0	-	-	0
Grade, %	0	-	0	-	-	0
Peak Hour Factor	95	95	95	95	95	95
Heavy Vehicles, %	2	2	2	2	2	2
Mvmt Flow	0	46	837	40	0	1211

Major/Minor	Minor1	Major1	Major2		
Conflicting Flow All	-	439	0	0	-
Stage 1	-	-	-	-	-
Stage 2	-	-	-	-	-
Critical Hdwy	-	6.94	-	-	-
Critical Hdwy Stg 1	-	-	-	-	-
Critical Hdwy Stg 2	-	-	-	-	-
Follow-up Hdwy	-	3.32	-	-	-
Pot Cap-1 Maneuver	0	566	-	-	0
Stage 1	0	-	-	-	0
Stage 2	0	-	-	-	0
Platoon blocked, %			-	-	-
Mov Cap-1 Maneuver	-	566	-	-	-
Mov Cap-2 Maneuver	-	-	-	-	-
Stage 1	-	-	-	-	-
Stage 2	-	-	-	-	-

Approach	WB	NB	SB
HCM Control Delay, s	11.9	0	0
HCM LOS	B		

Minor Lane/Major Mvmt	NBT	NBRWBLn1	SBT
Capacity (veh/h)	-	-	566
HCM Lane V/C Ratio	-	-	0.082
HCM Control Delay (s)	-	-	11.9
HCM Lane LOS	-	-	B
HCM 95th %tile Q(veh)	-	-	0.3

Intersection						
Int Delay, s/veh	3.3					
Movement	EBL	EBT	WBT	WBR	SBL	SBR
Lane Configurations	↖	↑↑	↑↑		↖	↖
Traffic Vol, veh/h	16	656	726	101	97	23
Future Vol, veh/h	16	656	726	101	97	23
Conflicting Peds, #/hr	0	0	0	0	0	0
Sign Control	Free	Free	Free	Free	Stop	Stop
RT Channelized	-	None	-	None	-	None
Storage Length	100	-	-	-	0	50
Veh in Median Storage, #	-	0	0	-	0	-
Grade, %	-	0	0	-	0	-
Peak Hour Factor	95	95	95	95	95	95
Heavy Vehicles, %	2	2	2	2	2	2
Mvmt Flow	17	691	764	106	102	24

Major/Minor	Major1	Major2	Minor2		
Conflicting Flow All	870	0	-	0	1197 435
Stage 1	-	-	-	-	817 -
Stage 2	-	-	-	-	380 -
Critical Hdwy	4.14	-	-	-	6.84 6.94
Critical Hdwy Stg 1	-	-	-	-	5.84 -
Critical Hdwy Stg 2	-	-	-	-	5.84 -
Follow-up Hdwy	2.22	-	-	-	3.52 3.32
Pot Cap-1 Maneuver	770	-	-	-	179 569
Stage 1	-	-	-	-	395 -
Stage 2	-	-	-	-	661 -
Platoon blocked, %		-	-	-	
Mov Cap-1 Maneuver	770	-	-	-	175 569
Mov Cap-2 Maneuver	-	-	-	-	175 -
Stage 1	-	-	-	-	386 -
Stage 2	-	-	-	-	661 -

Approach	EB	WB	SB
HCM Control Delay, s	0.2	0	43.4
HCM LOS			E

Minor Lane/Major Mvmt	EBL	EBT	WBT	WBR	SBLn1	SBLn2
Capacity (veh/h)	770	-	-	-	175	569
HCM Lane V/C Ratio	0.022	-	-	-	0.583	0.043
HCM Control Delay (s)	9.8	-	-	-	51	11.6
HCM Lane LOS	A	-	-	-	F	B
HCM 95th %tile Q(veh)	0.1	-	-	-	3.1	0.1



# **Cumulative (2032) Plus Project Conditions**

**Project Title:** BCHD-HLC  
**Intersection:** 1 - Prospect Av & Anita St  
**Description:** Future + Project

Thru Lane: 1600 vph  
 Left Lane: 1600 vph  
 Double Lt Penalty: 10 %  
 ITS: 0 %

N-S Split Phase : N  
 E-W Split Phase : N  
 Lost Time (% of cycle) : 10  
 V/C Round Off (decs.) : 3

OLA Movements :  
 FF Movements:

**Date/Time:** AM PEAK HOUR

APPROACH	MVMT	LANES	VOLUME	CAPACITY	V/C	ICU ANALYSIS	
Southbound	RT	0.00	33	0	0.000	N-S(1):	0.302 *
	TH	2.00	358	3,200	0.122	N-S(2):	0.287
	LT	1.00	63	1,600	0.039 *	E-W(1):	0.249
Westbound	RT	0.00	74	0	0.000	E-W(2):	0.275 *
	TH	2.00	752	3,200	0.258 *	V/C:	0.577
	LT	1.00	155	1,600	0.097	Lost Time:	0.100
Northbound	RT	1.00	210	1,600	0.083	ITS:	0.000
	TH	1.00	421	1,600	0.263 *	ICU:	0.677
	LT	1.00	263	1,600	0.165	LOS:	B
Eastbound	RT	0.00	83	0	0.000		
	TH	2.00	402	3,200	0.152		
	LT	1.00	27	1,600	0.017 *		

**Date/Time:** PM PEAK HOUR

APPROACH	MVMT	LANES	VOLUME	CAPACITY	V/C	ICU ANALYSIS	
Southbound	RT	0.00	40	0	0.000	N-S(1):	0.261 *
	TH	2.00	559	3,200	0.187 *	N-S(2):	0.261 *
	LT	1.00	73	1,600	0.046 *	E-W(1):	0.305 *
Westbound	RT	0.00	85	0	0.000	E-W(2):	0.247
	TH	2.00	628	3,200	0.223	V/C:	0.566
	LT	1.00	127	1,600	0.079 *	Lost Time:	0.100
Northbound	RT	1.00	94	1,600	0.019	ITS:	0.000
	TH	1.00	344	1,600	0.215 *	ICU:	0.666
	LT	1.00	119	1,600	0.074 *	LOS:	B
Eastbound	RT	0.00	121	0	0.000		
	TH	2.00	604	3,200	0.226 *		
	LT	1.00	39	1,600	0.024		

\* - Denotes critical movement

**Project Title:** BCHD-HLC  
**Intersection:** 2 - Harkness Ln & Anita St  
**Description:** Future + Project

Thru Lane: 1600 vph  
 Left Lane: 1600 vph  
 Double Lt Penalty: 10 %  
 ITS: 0 %

N-S Split Phase : N  
 E-W Split Phase : N  
 Lost Time (% of cycle) : 10  
 V/C Round Off (decs.) : 3

OLA Movements :  
 FF Movements:

**Date/Time:** AM PEAK HOUR

APPROACH	MVMT	LANES	VOLUME	CAPACITY	V/C	ICU ANALYSIS	
Southbound	RT	0.00	69	0	0.000	N-S(1):	0.132
	TH	1.00	118	1,600	0.138 *	N-S(2):	0.249 *
	LT	0.00	33	1,600	0.021	E-W(1):	0.238
Westbound	RT	0.00	22	0	0.000	E-W(2):	0.310 *
	TH	2.00	861	3,200	0.276 *	V/C:	0.559
	LT	1.00	121	1,600	0.075	Lost Time:	0.100
Northbound	RT	1.00	27	1,600	0.000	ITS:	0.000
	TH	0.78	138	1,247	0.111	ICU:	0.659
	LT	0.22	39	353	0.111 *	LOS:	B
Eastbound	RT	1.00	21	1,600	0.000		
	TH	2.00	523	3,200	0.163		
	LT	1.00	54	1,600	0.034 *		

**Date/Time:** PM PEAK HOUR

APPROACH	MVMT	LANES	VOLUME	CAPACITY	V/C	ICU ANALYSIS	
Southbound	RT	0.00	49	0	0.000	N-S(1):	0.064
	TH	1.00	97	1,600	0.106 *	N-S(2):	0.155 *
	LT	0.00	24	1,600	0.015	E-W(1):	0.238
Westbound	RT	0.00	9	0	0.000	E-W(2):	0.252 *
	TH	2.00	697	3,200	0.221 *	V/C:	0.407
	LT	1.00	37	1,600	0.023	Lost Time:	0.100
Northbound	RT	1.00	5	1,600	0.000	ITS:	0.000
	TH	0.84	66	1,337	0.049	ICU:	0.507
	LT	0.16	13	263	0.049 *	LOS:	A
Eastbound	RT	1.00	44	1,600	0.003		
	TH	2.00	688	3,200	0.215		
	LT	1.00	49	1,600	0.031 *		

\* - Denotes critical movement

**Project Title:** BCHD-HLC  
**Intersection:** 4 - Beryl St/Blossom Ln & 190th St  
**Description:** Future + Project

Thru Lane: 1600 vph  
 Left Lane: 1600 vph  
 Double Lt Penalty: 10 %  
 ITS: 0 %

N-S Split Phase : N  
 E-W Split Phase : N  
 Lost Time (% of cycle) : 10  
 V/C Round Off (decs.) : 3

OLA Movements :  
 FF Movements:

**Date/Time:** AM PEAK HOUR

APPROACH	MVMT	LANES	VOLUME	CAPACITY	V/C	ICU ANALYSIS	
Southbound	RT	1.00	23	1,600	0.008	N-S(1):	0.220 *
	TH	0.43	30	685	0.044	N-S(2):	0.050
	LT	0.57	40	915	0.044 *	E-W(1):	0.437 *
Westbound	RT	0.00	42	0	0.000	E-W(2):	0.273
	TH	2.00	793	3,200	0.261	V/C:	0.657
	LT	1.00	355	1,600	0.222 *	Lost Time:	0.100
Northbound	RT	1.00	459	1,600	0.176 *	ITS:	0.000
	TH	1.00	101	1,600	0.063	ICU:	0.757
	LT	1.00	9	1,600	0.006	LOS:	C
Eastbound	RT	1.00	10	1,600	0.003		
	TH	2.00	688	3,200	0.215 *		
	LT	1.00	19	1,600	0.012		

**Date/Time:** PM PEAK HOUR

APPROACH	MVMT	LANES	VOLUME	CAPACITY	V/C	ICU ANALYSIS	
Southbound	RT	1.00	17	1,600	0.007	N-S(1):	0.225 *
	TH	0.67	45	1,077	0.042	N-S(2):	0.045
	LT	0.33	22	523	0.042 *	E-W(1):	0.490 *
Westbound	RT	0.00	43	0	0.000	E-W(2):	0.269
	TH	2.00	792	3,200	0.261	V/C:	0.715
	LT	1.00	393	1,600	0.245 *	Lost Time:	0.100
Northbound	RT	1.00	490	1,600	0.183 *	ITS:	0.000
	TH	1.00	99	1,600	0.062	ICU:	0.815
	LT	1.00	4	1,600	0.003	LOS:	D
Eastbound	RT	1.00	13	1,600	0.007		
	TH	2.00	784	3,200	0.245 *		
	LT	1.00	13	1,600	0.008		

\* - Denotes critical movement

**Project Title:** BCHD-HLC  
**Intersection:** 5 - Entradero Av/Meyer Ln & 190th St  
**Description:** Future + Project

Thru Lane: 1600 vph  
 Left Lane: 1600 vph  
 Double Lt Penalty: 10 %  
 ITS: 0 %

N-S Split Phase : N  
 E-W Split Phase : N  
 Lost Time (% of cycle) : 10  
 V/C Round Off (decs.) : 3

OLA Movements :  
 FF Movements:

**Date/Time:** AM PEAK HOUR

APPROACH	MVMT	LANES	VOLUME	CAPACITY	V/C	ICU ANALYSIS	
Southbound	RT	0.00	27	0	0.000	N-S(1):	0.258 *
	TH	1.00	83	1,600	0.139	N-S(2):	0.186
	LT	0.00	112	1,600	0.070 *	E-W(1):	0.458 *
Westbound	RT	1.00	106	1,600	0.031	E-W(2):	0.416
	TH	2.00	1,269	3,200	0.397	V/C:	0.716
	LT	1.00	100	1,600	0.063 *	Lost Time:	0.100
Northbound	RT	0.00	113	0	0.000	ITS:	0.000
	TH	1.00	113	1,600	0.188 *	ICU:	0.816
	LT	0.00	75	1,600	0.047	LOS:	D
Eastbound	RT	1.00	49	1,600	0.007		
	TH	2.00	1,264	3,200	0.395 *		
	LT	1.00	31	1,600	0.019		

**Date/Time:** PM PEAK HOUR

APPROACH	MVMT	LANES	VOLUME	CAPACITY	V/C	ICU ANALYSIS	
Southbound	RT	0.00	31	0	0.000	N-S(1):	0.180 *
	TH	1.00	71	1,600	0.120	N-S(2):	0.148
	LT	0.00	89	1,600	0.056 *	E-W(1):	0.476 *
Westbound	RT	1.00	109	1,600	0.040	E-W(2):	0.457
	TH	2.00	1,359	3,200	0.425	V/C:	0.656
	LT	1.00	83	1,600	0.052 *	Lost Time:	0.100
Northbound	RT	0.00	94	0	0.000	ITS:	0.000
	TH	1.00	61	1,600	0.124 *	ICU:	0.756
	LT	0.00	44	1,600	0.028	LOS:	C
Eastbound	RT	1.00	88	1,600	0.041		
	TH	2.00	1,357	3,200	0.424 *		
	LT	1.00	51	1,600	0.032		

\* - Denotes critical movement

**Project Title:** BCHD-HLC  
**Intersection:** 6 - Anza Av & 190th St  
**Description:** Future + Project

Thru Lane: 1600 vph  
 Left Lane: 1600 vph  
 Double Lt Penalty: 10 %  
 ITS: 0 %

N-S Split Phase : N  
 E-W Split Phase : N  
 Lost Time (% of cycle) : 10  
 V/C Round Off (decs.) : 3

OLA Movements :  
 FF Movements:

**Date/Time:** AM PEAK HOUR

APPROACH	MVMT	LANES	VOLUME	CAPACITY	V/C	ICU ANALYSIS	
Southbound	RT	0.00	0	0	0.000	N-S(1):	0.255 *
	TH	0.00	0	0	0.000	N-S(2):	0.200
	LT	0.00	0	0	0.000 *	E-W(1):	0.484 *
Westbound	RT	0.00	0	0	0.000	E-W(2):	0.289
	TH	2.00	924	3,200	0.289	V/C:	0.739
	LT	2.00	485	2,880	0.168 *	Lost Time:	0.100
Northbound	RT	1.00	542	1,600	0.255 *	ITS:	0.000
	TH	0.00	0	0	0.000	ICU:	0.839
	LT	2.00	577	2,880	0.200	LOS:	D
Eastbound	RT	1.00	366	1,600	0.229		
	TH	2.00	1,010	3,200	0.316 *		
	LT	0.00	0	0	0.000		

**Date/Time:** PM PEAK HOUR

APPROACH	MVMT	LANES	VOLUME	CAPACITY	V/C	ICU ANALYSIS	
Southbound	RT	0.00	0	0	0.000	N-S(1):	0.236 *
	TH	0.00	0	0	0.000	N-S(2):	0.217
	LT	0.00	0	0	0.000 *	E-W(1):	0.545 *
Westbound	RT	0.00	0	0	0.000	E-W(2):	0.301
	TH	2.00	962	3,200	0.301	V/C:	0.781
	LT	2.00	602	2,880	0.209 *	Lost Time:	0.100
Northbound	RT	1.00	545	1,600	0.236 *	ITS:	0.000
	TH	0.00	0	0	0.000	ICU:	0.881
	LT	2.00	625	2,880	0.217	LOS:	D
Eastbound	RT	1.00	521	1,600	0.326		
	TH	2.00	1,076	3,200	0.336 *		
	LT	0.00	0	0	0.000		

\* - Denotes critical movement

**Project Title:** BCHD-HLC  
**Intersection:** 7 - Inglewood Ave & 190th St  
**Description:** Future + Project

Thru Lane: 1600 vph  
 Left Lane: 1600 vph  
 Double Lt Penalty: 10 %  
 ITS: 0 %

N-S Split Phase : N  
 E-W Split Phase : N  
 Lost Time (% of cycle) : 10  
 V/C Round Off (decs.) : 3

OLA Movements :  
 FF Movements:

**Date/Time:** AM PEAK HOUR

APPROACH	MVMT	LANES	VOLUME	CAPACITY	V/C	ICU ANALYSIS
Southbound	RT	1.00	573	1,600	0.253 *	N-S(1): 0.260
	TH	0.11	33	175	0.189	N-S(2): 0.263 *
	LT	0.89	269	1,425	0.189	E-W(1): 0.308
Westbound	RT	0.00	181	0	0.000	E-W(2): 0.425 *
	TH	3.00	855	4,800	0.216 *	V/C: 0.688
	LT	1.00	20	1,600	0.013	Lost Time: 0.100
Northbound	RT	0.00	29	0	0.000	ITS: 0.000
	TH	1.00	68	1,600	0.071	
	LT	0.00	16	1,600	0.010 *	
Eastbound	RT	0.00	5	0	0.000	ICU: 0.788
	TH	2.00	939	3,200	0.295	
	LT	2.00	603	2,880	0.209 *	LOS: C

**Date/Time:** PM PEAK HOUR

APPROACH	MVMT	LANES	VOLUME	CAPACITY	V/C	ICU ANALYSIS
Southbound	RT	1.00	595	1,600	0.257	N-S(1): 0.317 *
	TH	0.21	73	336	0.218	N-S(2): 0.278
	LT	0.79	275	1,264	0.218 *	E-W(1): 0.333
Westbound	RT	0.00	219	0	0.000	E-W(2): 0.487 *
	TH	3.00	1,014	4,800	0.257 *	V/C: 0.804
	LT	1.00	59	1,600	0.037	Lost Time: 0.100
Northbound	RT	0.00	16	0	0.000	ITS: 0.000
	TH	1.00	109	1,600	0.099 *	
	LT	0.00	34	1,600	0.021	
Eastbound	RT	0.00	15	0	0.000	ICU: 0.904
	TH	2.00	933	3,200	0.296	
	LT	2.00	661	2,880	0.230 *	LOS: E

\* - Denotes critical movement

**Project Title:** BCHD-HLC  
**Intersection:** 8 - Hawthorne Bl & 190th St  
**Description:** Future + Project

Thru Lane: 1600 vph  
 Left Lane: 1600 vph  
 Double Lt Penalty: 10 %  
 ITS: 0 %

N-S Split Phase : N  
 E-W Split Phase : N  
 Lost Time (% of cycle) : 10  
 V/C Round Off (decs.) : 3

OLA Movements :  
 FF Movements:

**Date/Time:** AM PEAK HOUR

APPROACH	MVMT	LANES	VOLUME	CAPACITY	V/C	ICU ANALYSIS	
Southbound	RT	1.00	175	1,600	0.078	N-S(1):	0.333
	TH	4.00	2,137	6,400	0.334 *	N-S(2):	0.394 *
	LT	2.00	92	2,880	0.032	E-W(1):	0.372 *
Westbound	RT	1.00	163	1,600	0.086	E-W(2):	0.295
	TH	2.00	740	3,200	0.231	V/C:	0.766
	LT	2.00	277	2,880	0.096 *	Lost Time:	0.100
Northbound	RT	1.00	210	1,600	0.083	ITS:	0.000
	TH	4.00	1,925	6,400	0.301	ICU:	0.866
	LT	2.00	174	2,880	0.060 *	LOS:	D
Eastbound	RT	1.00	249	1,600	0.125		
	TH	2.00	885	3,200	0.276 *		
	LT	2.00	184	2,880	0.064		

**Date/Time:** PM PEAK HOUR

APPROACH	MVMT	LANES	VOLUME	CAPACITY	V/C	ICU ANALYSIS	
Southbound	RT	1.00	194	1,600	0.096	N-S(1):	0.402 *
	TH	4.00	1,745	6,400	0.273	N-S(2):	0.380
	LT	2.00	175	2,880	0.061 *	E-W(1):	0.358 *
Westbound	RT	1.00	166	1,600	0.073	E-W(2):	0.333
	TH	2.00	901	3,200	0.282	V/C:	0.760
	LT	2.00	324	2,880	0.113 *	Lost Time:	0.100
Northbound	RT	1.00	415	1,600	0.203	ITS:	0.000
	TH	4.00	2,182	6,400	0.341 *	ICU:	0.860
	LT	2.00	309	2,880	0.107	LOS:	D
Eastbound	RT	1.00	321	1,600	0.147		
	TH	2.00	785	3,200	0.245 *		
	LT	2.00	148	2,880	0.051		

\* - Denotes critical movement



**Project Title:** BCHD-HLC  
**Intersection:** 9 - Prospect Av & Beryl St  
**Description:** Future + Project

Thru Lane: 1600 vph  
 Left Lane: 1600 vph  
 Double Lt Penalty: 10 %  
 ITS: 0 %

N-S Split Phase : N  
 E-W Split Phase : N  
 Lost Time (% of cycle) : 10  
 V/C Round Off (decs.) : 3

OLA Movements :  
 FF Movements:

**Date/Time:** AM PEAK HOUR

APPROACH	MVMT	LANES	VOLUME	CAPACITY	V/C	ICU ANALYSIS	
Southbound	RT	0.00	116	0	0.000	N-S(1):	0.344 *
	TH	2.00	482	3,200	0.187	N-S(2):	0.228
	LT	1.00	17	1,600	0.011 *	E-W(1):	0.379 *
Westbound	RT	1.00	18	1,600	0.006	E-W(2):	0.305
	TH	1.00	389	1,600	0.243	V/C:	0.723
	LT	1.00	368	1,600	0.230 *	Lost Time:	0.100
Northbound	RT	0.00	322	0	0.000	ITS:	0.000
	TH	2.00	744	3,200	0.333 *	ICU:	0.823
	LT	1.00	65	1,600	0.041	LOS:	D
Eastbound	RT	0.00	51	0	0.000		
	TH	2.00	427	3,200	0.149 *		
	LT	1.00	99	1,600	0.062		

**Date/Time:** PM PEAK HOUR

APPROACH	MVMT	LANES	VOLUME	CAPACITY	V/C	ICU ANALYSIS	
Southbound	RT	0.00	57	0	0.000	N-S(1):	0.276
	TH	2.00	704	3,200	0.238 *	N-S(2):	0.297 *
	LT	1.00	40	1,600	0.025	E-W(1):	0.309 *
Westbound	RT	1.00	32	1,600	0.008	E-W(2):	0.209
	TH	1.00	298	1,600	0.186	V/C:	0.606
	LT	1.00	294	1,600	0.184 *	Lost Time:	0.100
Northbound	RT	0.00	296	0	0.000	ITS:	0.000
	TH	2.00	508	3,200	0.251	ICU:	0.706
	LT	1.00	94	1,600	0.059 *	LOS:	C
Eastbound	RT	0.00	44	0	0.000		
	TH	2.00	356	3,200	0.125 *		
	LT	1.00	37	1,600	0.023		

\* - Denotes critical movement

**Project Title:** BCHD-HLC  
**Intersection:** 13 - Prospect Av & Middle Campus Driveway  
**Description:** Future + Project

Thru Lane: 1600 vph  
 Left Lane: 1600 vph  
 Double Lt Penalty: 10 %  
 ITS: 0 %

N-S Split Phase : N  
 E-W Split Phase : N  
 Lost Time (% of cycle) : 10  
 V/C Round Off (decs.) : 3

OLA Movements :  
 FF Movements:

**Date/Time:** AM PEAK HOUR

APPROACH	MVMT	LANES	VOLUME	CAPACITY	V/C	ICU ANALYSIS	
Southbound	RT	0.20	0	320	0.000	N-S(1):	0.432
	TH	0.80	805	1,280	0.629 *	N-S(2):	0.629 *
	LT	1.00	102	1,600	0.064	E-W(1):	0.079 *
Westbound	RT	1.00	32	1,600	0.000	E-W(2):	0.000
	TH	0.00	0	0	0.000	V/C:	0.708
	LT	1.00	127	1,600	0.079 *	Lost Time:	0.100
Northbound	RT	0.00	62	0	0.000	ITS:	0.000
	TH	2.00	1,116	3,200	0.368	ICU:	0.808
	LT	1.00	0	1,600	0.000 *	LOS:	D
Eastbound	RT	0.00	0	0	0.000		
	TH	1.00	0	1,600	0.000 *		
	LT	0.00	0	0	0.000		

**Date/Time:** PM PEAK HOUR

APPROACH	MVMT	LANES	VOLUME	CAPACITY	V/C	ICU ANALYSIS	
Southbound	RT	0.00	0	0	0.000	N-S(1):	0.278
	TH	2.00	1,043	3,200	0.326 *	N-S(2):	0.327 *
	LT	1.00	40	1,600	0.025	E-W(1):	0.074 *
Westbound	RT	1.00	93	1,600	0.045	E-W(2):	0.045
	TH	0.00	0	0	0.000	V/C:	0.401
	LT	1.00	119	1,600	0.074 *	Lost Time:	0.100
Northbound	RT	0.00	13	0	0.000	ITS:	0.000
	TH	2.00	798	3,200	0.253	ICU:	0.501
	LT	1.00	2	1,600	0.001 *	LOS:	A
Eastbound	RT	0.00	0	0	0.000		
	TH	1.00	0	1,600	0.000 *		
	LT	0.00	0	0	0.000		

\* - Denotes critical movement

**Project Title:** BCHD-HLC  
**Intersection:** 15 - Prospect Av & Diamond St  
**Description:** Future + Project

Thru Lane: 1600 vph  
 Left Lane: 1600 vph  
 Double Lt Penalty: 10 %  
 ITS: 0 %

N-S Split Phase : N  
 E-W Split Phase : N  
 Lost Time (% of cycle) : 10  
 V/C Round Off (decs.) : 3

OLA Movements :  
 FF Movements:

**Date/Time:** AM PEAK HOUR

APPROACH	MVMT	LANES	VOLUME	CAPACITY	V/C	ICU ANALYSIS	
Southbound	RT	0.00	199	0	0.000	N-S(1):	0.354 *
	TH	2.00	645	3,200	0.264	N-S(2):	0.302
	LT	1.00	7	1,600	0.004 *	E-W(1):	0.066
Westbound	RT	1.00	3	1,600	0.000	E-W(2):	0.072 *
	TH	1.00	0	1,600	0.000 *	V/C:	0.426
	LT	1.00	1	1,600	0.001	Lost Time:	0.100
Northbound	RT	0.00	0	0	0.000	ITS:	0.000
	TH	2.00	1,119	3,200	0.350 *	ICU:	0.526
	LT	1.00	61	1,600	0.038	LOS:	A
Eastbound	RT	0.00	69	0	0.000		
	TH	0.67	0	1,070	0.065		
	LT	1.33	137	1,917	0.072 *		

**Date/Time:** PM PEAK HOUR

APPROACH	MVMT	LANES	VOLUME	CAPACITY	V/C	ICU ANALYSIS	
Southbound	RT	0.00	68	0	0.000	N-S(1):	0.244
	TH	2.00	1,080	3,200	0.359 *	N-S(2):	0.365 *
	LT	1.00	13	1,600	0.008	E-W(1):	0.025
Westbound	RT	1.00	2	1,600	0.001 *	E-W(2):	0.028 *
	TH	1.00	0	1,600	0.000	V/C:	0.393
	LT	1.00	0	1,600	0.000	Lost Time:	0.100
Northbound	RT	0.00	3	0	0.000	ITS:	0.000
	TH	2.00	751	3,200	0.236	ICU:	0.493
	LT	1.00	9	1,600	0.006 *	LOS:	A
Eastbound	RT	0.00	23	0	0.000		
	TH	0.58	0	932	0.025		
	LT	1.42	56	2,042	0.027 *		

\* - Denotes critical movement

**Project Title:** BCHD-HLC  
**Intersection:** 16 - Hallison St & Anza Av  
**Description:** Future + Project

Thru Lane: 1600 vph  
 Left Lane: 1600 vph  
 Double Lt Penalty: 10 %  
 ITS: 0 %

N-S Split Phase : N  
 E-W Split Phase : N  
 Lost Time (% of cycle) : 10  
 V/C Round Off (decs.) : 3

OLA Movements :  
 FF Movements:

**Date/Time:** AM PEAK HOUR

APPROACH	MVMT	LANES	VOLUME	CAPACITY	V/C	ICU ANALYSIS	
Southbound	RT	0.00	23	0	0.000	N-S(1):	0.360 *
	TH	2.00	971	3,200	0.311	N-S(2):	0.328
	LT	1.00	30	1,600	0.019 *	E-W(1):	0.145
Westbound	RT	0.00	48	0	0.000	E-W(2):	0.147 *
	TH	1.00	61	1,600	0.106 *	V/C:	0.507
	LT	0.00	61	1,600	0.038	Lost Time:	0.100
Northbound	RT	0.00	26	0	0.000	ITS:	0.000
	TH	2.00	1,065	3,200	0.341 *	ICU:	0.607
	LT	1.00	27	1,600	0.017	LOS:	B
Eastbound	RT	0.00	62	0	0.000		
	TH	1.00	43	1,600	0.107		
	LT	0.00	66	1,600	0.041 *		

**Date/Time:** PM PEAK HOUR

APPROACH	MVMT	LANES	VOLUME	CAPACITY	V/C	ICU ANALYSIS	
Southbound	RT	0.00	37	0	0.000	N-S(1):	0.423 *
	TH	2.00	1,193	3,200	0.384	N-S(2):	0.408
	LT	1.00	30	1,600	0.019 *	E-W(1):	0.051
Westbound	RT	0.00	37	0	0.000	E-W(2):	0.075 *
	TH	1.00	31	1,600	0.063 *	V/C:	0.498
	LT	0.00	33	1,600	0.021	Lost Time:	0.100
Northbound	RT	0.00	31	0	0.000	ITS:	0.000
	TH	2.00	1,262	3,200	0.404 *	ICU:	0.598
	LT	1.00	39	1,600	0.024	LOS:	A
Eastbound	RT	0.00	13	0	0.000		
	TH	1.00	16	1,600	0.030		
	LT	0.00	19	1,600	0.012 *		

\* - Denotes critical movement

**Project Title:** BCHD-HLC  
**Intersection:** 17 - Prospect Av & Del Amo Bl  
**Description:** Future + Project

Thru Lane: 1600 vph  
 Left Lane: 1600 vph  
 Double Lt Penalty: 10 %  
 ITS: 0 %

N-S Split Phase : N  
 E-W Split Phase : N  
 Lost Time (% of cycle) : 10  
 V/C Round Off (decs.) : 3

OLA Movements :  
 FF Movements:

**Date/Time:** AM PEAK HOUR

APPROACH	MVMT	LANES	VOLUME	CAPACITY	V/C	ICU ANALYSIS	
Southbound	RT	0.00	39	0	0.000	N-S(1):	0.433 *
	TH	2.00	589	3,200	0.196	N-S(2):	0.285
	LT	1.00	76	1,600	0.048 *	E-W(1):	0.314 *
Westbound	RT	1.00	261	1,600	0.139	E-W(2):	0.189
	TH	1.00	266	1,600	0.166	V/C:	0.747
	LT	1.00	277	1,600	0.173 *	Lost Time:	0.100
Northbound	RT	0.00	358	0	0.000	ITS:	0.000
	TH	2.00	874	3,200	0.385 *	ICU:	0.847
	LT	1.00	142	1,600	0.089	LOS:	D
Eastbound	RT	1.00	151	1,600	0.050		
	TH	1.00	225	1,600	0.141 *		
	LT	1.00	36	1,600	0.023		

**Date/Time:** PM PEAK HOUR

APPROACH	MVMT	LANES	VOLUME	CAPACITY	V/C	ICU ANALYSIS	
Southbound	RT	0.00	5	0	0.000	N-S(1):	0.390 *
	TH	2.00	903	3,200	0.284	N-S(2):	0.345
	LT	1.00	196	1,600	0.122 *	E-W(1):	0.315 *
Westbound	RT	1.00	203	1,600	0.066	E-W(2):	0.127
	TH	1.00	186	1,600	0.116	V/C:	0.705
	LT	1.00	331	1,600	0.207 *	Lost Time:	0.100
Northbound	RT	0.00	300	0	0.000	ITS:	0.000
	TH	2.00	556	3,200	0.268 *	ICU:	0.805
	LT	1.00	97	1,600	0.061	LOS:	D
Eastbound	RT	1.00	140	1,600	0.057		
	TH	1.00	172	1,600	0.108 *		
	LT	1.00	17	1,600	0.011		

\* - Denotes critical movement

**Project Title: BCHD-HLC**  
**Intersection: 19 - Wayne Av & Del Amo BI**  
**Description: Future + Project**

Thru Lane: 1600 vph  
 Left Lane: 1600 vph  
 Double Lt Penalty: 10 %  
 ITS: 0 %

N-S Split Phase : N  
 E-W Split Phase : N  
 Lost Time (% of cycle) : 10  
 V/C Round Off (decs.) : 3

OLA Movements :  
 FF Movements:

**Date/Time: AM PEAK HOUR**

APPROACH	MVMT	LANES	VOLUME	CAPACITY	V/C	ICU ANALYSIS	
Southbound	RT	0.00	34	0	0.000	N-S(1):	0.116 *
	TH	1.00	30	1,600	0.063	N-S(2):	0.094
	LT	0.00	36	1,600	0.023 *	E-W(1):	0.229
Westbound	RT	0.00	15	0	0.000	E-W(2):	0.248 *
	TH	2.00	758	3,200	0.241 *	V/C:	0.364
	LT	1.00	20	1,600	0.013	Lost Time:	0.100
Northbound	RT	0.00	80	0	0.000	ITS:	0.000
	TH	1.00	19	1,600	0.093 *	ICU:	0.464
	LT	0.00	50	1,600	0.031	LOS:	A
Eastbound	RT	0.00	6	0	0.000		
	TH	2.00	686	3,200	0.216		
	LT	1.00	11	1,600	0.007 *		

**Date/Time: PM PEAK HOUR**

APPROACH	MVMT	LANES	VOLUME	CAPACITY	V/C	ICU ANALYSIS	
Southbound	RT	0.00	7	0	0.000	N-S(1):	0.049 *
	TH	1.00	9	1,600	0.028	N-S(2):	0.032
	LT	0.00	28	1,600	0.018 *	E-W(1):	0.255
Westbound	RT	0.00	23	0	0.000	E-W(2):	0.259 *
	TH	2.00	784	3,200	0.252 *	V/C:	0.308
	LT	1.00	32	1,600	0.020	Lost Time:	0.100
Northbound	RT	0.00	38	0	0.000	ITS:	0.000
	TH	1.00	5	1,600	0.031 *	ICU:	0.408
	LT	0.00	7	1,600	0.004	LOS:	A
Eastbound	RT	0.00	7	0	0.000		
	TH	2.00	745	3,200	0.235		
	LT	1.00	11	1,600	0.007 *		

\* - Denotes critical movement

**Project Title:** BCHD-HLC  
**Intersection:** 20 - Henrietta St & Del Amo Bl  
**Description:** Future + Project

Thru Lane: 1600 vph  
 Left Lane: 1600 vph  
 Double Lt Penalty: 10 %  
 ITS: 0 %

N-S Split Phase : N  
 E-W Split Phase : N  
 Lost Time (% of cycle) : 10  
 V/C Round Off (decs.) : 3

OLA Movements :  
 FF Movements:

**Date/Time:** AM PEAK HOUR

APPROACH	MVMT	LANES	VOLUME	CAPACITY	V/C	ICU ANALYSIS	
Southbound	RT	0.00	0	0	0.000	N-S(1):	0.048
	TH	0.00	0	0	0.000 *	N-S(2):	0.079 *
	LT	0.00	0	0	0.000	E-W(1):	0.357 *
Westbound	RT	0.00	0	0	0.000	E-W(2):	0.213
	TH	2.00	681	3,200	0.213	V/C:	0.436
	LT	1.00	169	1,600	0.106 *	Lost Time:	0.100
Northbound	RT	1.00	161	1,600	0.048	ITS:	0.000
	TH	0.00	0	0	0.000	ICU:	0.536
	LT	1.00	126	1,600	0.079 *	LOS:	A
Eastbound	RT	0.00	45	0	0.000		
	TH	2.00	759	3,200	0.251 *		
	LT	0.00	0	0	0.000		

**Date/Time:** PM PEAK HOUR

APPROACH	MVMT	LANES	VOLUME	CAPACITY	V/C	ICU ANALYSIS	
Southbound	RT	0.00	0	0	0.000	N-S(1):	0.036
	TH	0.00	0	0	0.000 *	N-S(2):	0.048 *
	LT	0.00	0	0	0.000	E-W(1):	0.345 *
Westbound	RT	0.00	0	0	0.000	E-W(2):	0.238
	TH	2.00	761	3,200	0.238	V/C:	0.393
	LT	1.00	150	1,600	0.094 *	Lost Time:	0.100
Northbound	RT	1.00	132	1,600	0.036	ITS:	0.000
	TH	0.00	0	0	0.000	ICU:	0.493
	LT	1.00	76	1,600	0.048 *	LOS:	A
Eastbound	RT	0.00	79	0	0.000		
	TH	2.00	724	3,200	0.251 *		
	LT	0.00	0	0	0.000		

\* - Denotes critical movement

**Project Title:** BCHD-HLC  
**Intersection:** 21 - Entradero Av & Del Amo Bl  
**Description:** Future + Project

Thru Lane: 1600 vph  
 Left Lane: 1600 vph  
 Double Lt Penalty: 10 %  
 ITS: 0 %

N-S Split Phase : N  
 E-W Split Phase : N  
 Lost Time (% of cycle) : 10  
 V/C Round Off (decs.) : 3

OLA Movements :  
 FF Movements:

**Date/Time:** AM PEAK HOUR

APPROACH	MVMT	LANES	VOLUME	CAPACITY	V/C	ICU ANALYSIS
Southbound	RT	0.54	224	859	0.214	N-S(1): 0.261 *
	TH	0.00	0	0	0.000	N-S(2): 0.214
	LT	0.46	193	741	0.261 *	E-W(1): 0.231
Westbound	RT	0.00	185	0	0.000	E-W(2): 0.359 *
	TH	2.00	665	3,200	0.266 *	V/C: 0.620
	LT	0.00	0	0	0.000	Lost Time: 0.100
Northbound	RT	0.00	0	0	0.000	ITS: 0.000
	TH	0.00	0	0	0.000 *	
	LT	0.00	0	0	0.000	
Eastbound	RT	0.00	0	0	0.000	ICU: 0.720
	TH	2.00	739	3,200	0.231	
	LT	1.00	148	1,600	0.093 *	LOS: C

**Date/Time:** PM PEAK HOUR

APPROACH	MVMT	LANES	VOLUME	CAPACITY	V/C	ICU ANALYSIS
Southbound	RT	0.48	91	774	0.096	N-S(1): 0.118 *
	TH	0.00	0	0	0.000	N-S(2): 0.096
	LT	0.52	97	826	0.118 *	E-W(1): 0.244
Westbound	RT	0.00	95	0	0.000	E-W(2): 0.335 *
	TH	2.00	835	3,200	0.291 *	V/C: 0.453
	LT	0.00	0	0	0.000	Lost Time: 0.100
Northbound	RT	0.00	0	0	0.000	ITS: 0.000
	TH	0.00	0	0	0.000 *	
	LT	0.00	0	0	0.000	
Eastbound	RT	0.00	0	0	0.000	ICU: 0.553
	TH	2.00	781	3,200	0.244	
	LT	1.00	70	1,600	0.044 *	LOS: A

\* - Denotes critical movement



**Project Title:** BCHD-HLC  
**Intersection:** 22 - Victor St & Del Amo BI  
**Description:** Future + Project

Thru Lane: 1600 vph  
 Left Lane: 1600 vph  
 Double Lt Penalty: 10 %  
 ITS: 0 %

N-S Split Phase : N  
 E-W Split Phase : N  
 Lost Time (% of cycle) : 10  
 V/C Round Off (decs.) : 3

OLA Movements :  
 FF Movements:

**Date/Time:** AM PEAK HOUR

APPROACH	MVMT	LANES	VOLUME	CAPACITY	V/C	ICU ANALYSIS	
Southbound	RT	0.00	0	0	0.000	N-S(1):	0.103 *
	TH	0.00	0	0	0.000	N-S(2):	0.077
	LT	0.00	0	0	0.000 *	E-W(1):	0.370 *
Westbound	RT	0.00	0	0	0.000	E-W(2):	0.173
	TH	2.00	555	3,200	0.173	V/C:	0.473
	LT	1.00	137	1,600	0.086 *	Lost Time:	0.100
Northbound	RT	1.00	233	1,600	0.103 *	ITS:	0.000
	TH	0.00	0	0	0.000	ICU:	0.573
	LT	1.00	122	1,600	0.077	LOS:	A
Eastbound	RT	0.00	177	0	0.000		
	TH	2.00	732	3,200	0.284 *		
	LT	0.00	0	0	0.000		

**Date/Time:** PM PEAK HOUR

APPROACH	MVMT	LANES	VOLUME	CAPACITY	V/C	ICU ANALYSIS	
Southbound	RT	0.00	0	0	0.000	N-S(1):	0.038 *
	TH	0.00	0	0	0.000	N-S(2):	0.029
	LT	0.00	0	0	0.000 *	E-W(1):	0.318 *
Westbound	RT	0.00	0	0	0.000	E-W(2):	0.278
	TH	2.00	890	3,200	0.278	V/C:	0.356
	LT	1.00	71	1,600	0.044 *	Lost Time:	0.100
Northbound	RT	1.00	96	1,600	0.038 *	ITS:	0.000
	TH	0.00	0	0	0.000	ICU:	0.456
	LT	1.00	47	1,600	0.029	LOS:	A
Eastbound	RT	0.00	59	0	0.000		
	TH	2.00	817	3,200	0.274 *		
	LT	0.00	0	0	0.000		

\* - Denotes critical movement

**Project Title:** BCHD-HLC  
**Intersection:** 23 - Anza Av & Del Amo Bl  
**Description:** Future + Project

Thru Lane: 1600 vph  
 Left Lane: 1600 vph  
 Double Lt Penalty: 10 %  
 ITS: 0 %

N-S Split Phase : N  
 E-W Split Phase : N  
 Lost Time (% of cycle) : 10  
 V/C Round Off (decs.) : 3

OLA Movements :  
 FF Movements:

**Date/Time:** AM PEAK HOUR

APPROACH	MVMT	LANES	VOLUME	CAPACITY	V/C	ICU ANALYSIS	
Southbound	RT	0.00	138	0	0.000	N-S(1):	0.357
	TH	2.00	772	3,200	0.284 *	N-S(2):	0.359 *
	LT	1.00	170	1,600	0.106	E-W(1):	0.344 *
Westbound	RT	0.00	136	0	0.000	E-W(2):	0.344 *
	TH	2.00	622	3,200	0.237 *	V/C:	0.703
	LT	1.00	147	1,600	0.092 *	Lost Time:	0.100
Northbound	RT	1.00	221	1,600	0.092	ITS:	0.000
	TH	2.00	802	3,200	0.251	ICU:	0.803
	LT	1.00	119	1,600	0.075 *	LOS:	D
Eastbound	RT	1.00	124	1,600	0.040		
	TH	2.00	807	3,200	0.252 *		
	LT	1.00	171	1,600	0.107 *		

**Date/Time:** PM PEAK HOUR

APPROACH	MVMT	LANES	VOLUME	CAPACITY	V/C	ICU ANALYSIS	
Southbound	RT	0.00	117	0	0.000	N-S(1):	0.393
	TH	2.00	1,014	3,200	0.353 *	N-S(2):	0.464 *
	LT	1.00	113	1,600	0.071	E-W(1):	0.332
Westbound	RT	0.00	171	0	0.000	E-W(2):	0.407 *
	TH	2.00	738	3,200	0.284 *	V/C:	0.871
	LT	1.00	230	1,600	0.144	Lost Time:	0.100
Northbound	RT	1.00	146	1,600	0.019	ITS:	0.000
	TH	2.00	1,031	3,200	0.322	ICU:	0.971
	LT	1.00	177	1,600	0.111 *	LOS:	E
Eastbound	RT	1.00	141	1,600	0.033		
	TH	2.00	603	3,200	0.188		
	LT	1.00	197	1,600	0.123 *		

\* - Denotes critical movement

**Project Title:** BCHD-HLC  
**Intersection:** 24 - Hawthorne BI & Del Amo BI  
**Description:** Future + Project

Thru Lane: 1600 vph  
 Left Lane: 1600 vph  
 Double Lt Penalty: 10 %  
 ITS: 0 %

N-S Split Phase : N  
 E-W Split Phase : N  
 Lost Time (% of cycle) : 10  
 V/C Round Off (decs.) : 3

OLA Movements :  
 FF Movements:

**Date/Time:** AM PEAK HOUR

APPROACH	MVMT	LANES	VOLUME	CAPACITY	V/C	ICU ANALYSIS	
Southbound	RT	0.00	193	0	0.000	N-S(1):	0.380
	TH	4.00	2,165	6,400	0.368 *	N-S(2):	0.462 *
	LT	2.00	138	2,880	0.048	E-W(1):	0.369 *
Westbound	RT	1.00	87	1,600	0.030	E-W(2):	0.340
	TH	2.00	753	3,200	0.235	V/C:	0.831
	LT	2.00	244	2,880	0.085 *	Lost Time:	0.100
Northbound	RT	0.00	212	0	0.000	ITS:	0.000
	TH	4.00	1,915	6,400	0.332	ICU:	0.931
	LT	1.00	150	1,600	0.094 *	LOS:	E
Eastbound	RT	1.00	71	1,600	0.000		
	TH	2.00	910	3,200	0.284 *		
	LT	2.00	301	2,880	0.105		

**Date/Time:** PM PEAK HOUR

APPROACH	MVMT	LANES	VOLUME	CAPACITY	V/C	ICU ANALYSIS	
Southbound	RT	0.00	215	0	0.000	N-S(1):	0.415
	TH	4.00	2,064	6,400	0.356 *	N-S(2):	0.447 *
	LT	2.00	153	2,880	0.053	E-W(1):	0.324
Westbound	RT	1.00	202	1,600	0.100	E-W(2):	0.419 *
	TH	2.00	976	3,200	0.305 *	V/C:	0.866
	LT	2.00	300	2,880	0.104	Lost Time:	0.100
Northbound	RT	0.00	112	0	0.000	ITS:	0.000
	TH	4.00	2,207	6,400	0.362	ICU:	0.966
	LT	1.00	145	1,600	0.091 *	LOS:	E
Eastbound	RT	1.00	133	1,600	0.038		
	TH	2.00	704	3,200	0.220		
	LT	2.00	329	2,880	0.114 *		

\* - Denotes critical movement

**Project Title:** BCHD-HLC  
**Intersection:** 25 - Prospect Av & Torrance Bl  
**Description:** Future + Project

Thru Lane: 1600 vph  
 Left Lane: 1600 vph  
 Double Lt Penalty: 10 %  
 ITS: 0 %

N-S Split Phase : N  
 E-W Split Phase : N  
 Lost Time (% of cycle) : 10  
 V/C Round Off (decs.) : 3

OLA Movements :  
 FF Movements:

**Date/Time:** AM PEAK HOUR

APPROACH	MVMT	LANES	VOLUME	CAPACITY	V/C	ICU ANALYSIS	
Southbound	RT	0.00	93	0	0.000	N-S(1):	0.410 *
	TH	2.00	588	3,200	0.213	N-S(2):	0.254
	LT	1.00	188	1,600	0.117 *	E-W(1):	0.200
Westbound	RT	0.00	176	0	0.000	E-W(2):	0.234 *
	TH	3.00	567	4,800	0.155 *	V/C:	0.644
	LT	1.00	130	1,600	0.081	Lost Time:	0.100
Northbound	RT	0.00	214	0	0.000	ITS:	0.000
	TH	2.00	722	3,200	0.293 *	ICU:	0.744
	LT	1.00	66	1,600	0.041	LOS:	C
Eastbound	RT	0.00	28	0	0.000		
	TH	3.00	541	4,800	0.119		
	LT	1.00	127	1,600	0.079 *		

**Date/Time:** PM PEAK HOUR

APPROACH	MVMT	LANES	VOLUME	CAPACITY	V/C	ICU ANALYSIS	
Southbound	RT	0.00	141	0	0.000	N-S(1):	0.392 *
	TH	2.00	855	3,200	0.311	N-S(2):	0.340
	LT	1.00	252	1,600	0.158 *	E-W(1):	0.239
Westbound	RT	0.00	200	0	0.000	E-W(2):	0.263 *
	TH	3.00	677	4,800	0.183 *	V/C:	0.655
	LT	1.00	164	1,600	0.103	Lost Time:	0.100
Northbound	RT	0.00	109	0	0.000	ITS:	0.000
	TH	2.00	641	3,200	0.234 *	ICU:	0.755
	LT	1.00	46	1,600	0.029	LOS:	C
Eastbound	RT	0.00	43	0	0.000		
	TH	3.00	608	4,800	0.136		
	LT	1.00	128	1,600	0.080 *		

\* - Denotes critical movement

Intersection	
Intersection Delay, s/veh	142.8
Intersection LOS	F

Movement	EBL	EBT	EBR	WBL	WBT	WBR	NBL	NBT	NBR	SBL	SBT	SBR
Lane Configurations		↔↔			↔↔		↗	↑	↖		↖	↗
Traffic Vol, veh/h	49	525	8	35	724	1	57	245	67	111	194	217
Future Vol, veh/h	49	525	8	35	724	1	57	245	67	111	194	217
Peak Hour Factor	0.90	0.90	0.90	0.90	0.90	0.90	0.90	0.90	0.90	0.90	0.90	0.90
Heavy Vehicles, %	2	2	2	2	2	2	2	2	2	2	2	2
Mvmt Flow	54	583	9	39	804	1	63	272	74	123	216	241
Number of Lanes	0	2	0	0	2	0	1	1	1	0	1	1

Approach	EB	WB	NB	SB
Opposing Approach	WB	EB	SB	NB
Opposing Lanes	2	2	2	3
Conflicting Approach Left	SB	NB	EB	WB
Conflicting Lanes Left	2	3	2	2
Conflicting Approach Right	NB	SB	WB	EB
Conflicting Lanes Right	3	2	2	2
HCM Control Delay	113.9	230.8	67.8	100.1
HCM LOS	F	F	F	F

Lane	NBLn1	NBLn2	NBLn3	EBLn1	EBLn2	WBLn1	WBLn2	SBLn1	SBLn2
Vol Left, %	100%	0%	0%	16%	0%	9%	0%	36%	0%
Vol Thru, %	0%	100%	0%	84%	97%	91%	100%	64%	0%
Vol Right, %	0%	0%	100%	0%	3%	0%	0%	0%	100%
Sign Control	Stop	Stop	Stop	Stop	Stop	Stop	Stop	Stop	Stop
Traffic Vol by Lane	57	245	67	312	271	397	363	305	217
LT Vol	57	0	0	49	0	35	0	111	0
Through Vol	0	245	0	263	263	362	362	194	0
RT Vol	0	0	67	0	8	0	1	0	217
Lane Flow Rate	63	272	74	346	301	441	403	339	241
Geometry Grp	8	8	8	8	8	8	8	8	8
Degree of Util (X)	0.233	0.964	0.249	1.146	0.987	1.46	1.329	1.15	0.76
Departure Headway (Hd)	15.596	15.07	14.333	12.887	12.783	12.496	12.447	13.22	12.286
Convergence, Y/N	Yes	Yes	Yes	Yes	Yes	Yes	Yes	Yes	Yes
Cap	232	242	252	284	286	296	294	278	297
Service Time	13.296	12.77	12.033	10.587	10.483	10.196	10.147	10.92	9.986
HCM Lane V/C Ratio	0.272	1.124	0.294	1.218	1.052	1.49	1.371	1.219	0.811
HCM Control Delay	23	90.9	21.7	136.3	88	256.3	202.9	139	45.4
HCM Lane LOS	C	F	C	F	F	F	F	F	E
HCM 95th-tile Q	0.9	8.8	1	13.8	10	23.3	19.3	13.7	5.7

**Intersection**

Intersection Delay, s/veh 134.9

Intersection LOS F

Movement	EBL	EBT	EBR	WBL	WBT	WBR	NBL	NBT	NBR	SBL	SBT	SBR
Lane Configurations												
Traffic Vol, veh/h	143	617	8	23	492	6	15	20	28	15	8	268
Future Vol, veh/h	143	617	8	23	492	6	15	20	28	15	8	268
Peak Hour Factor	0.85	0.85	0.85	0.85	0.85	0.85	0.85	0.85	0.85	0.85	0.85	0.85
Heavy Vehicles, %	2	2	2	2	2	2	2	2	2	2	2	2
Mvmt Flow	168	726	9	27	579	7	18	24	33	18	9	315
Number of Lanes	1	1	0	1	1	0	0	1	0	0	1	0

Approach	EB	WB	NB	SB
Opposing Approach	WB	EB	SB	NB
Opposing Lanes	2	2	1	1
Conflicting Approach Left	SB	NB	EB	WB
Conflicting Lanes Left	1	1	2	2
Conflicting Approach Right	NB	SB	WB	EB
Conflicting Lanes Right	1	1	2	2
HCM Control Delay	195	122.5	14.8	24.4
HCM LOS	F	F	B	C

Lane	NBLn1	EBLn1	EBLn2	WBLn1	WBLn2	SBLn1
Vol Left, %		24%	100%	0%	100%	0%
Vol Thru, %		32%	0%	99%	0%	99%
Vol Right, %		44%	0%	1%	0%	1%
Sign Control		Stop	Stop	Stop	Stop	Stop
Traffic Vol by Lane		63	143	625	23	498
LT Vol		15	143	0	23	0
Through Vol		20	0	617	0	492
RT Vol		28	0	8	0	6
Lane Flow Rate		74	168	735	27	586
Geometry Grp		2	7	7	7	7
Degree of Util (X)		0.175	0.356	1.454	0.058	1.181
Departure Headway (Hd)		9.718	8.029	7.504	8.379	7.853
Convergence, Y/N		Yes	Yes	Yes	Yes	Yes
Cap		371	451	493	430	469
Service Time		7.718	5.729	5.204	6.079	5.553
HCM Lane V/C Ratio		0.199	0.373	1.491	0.063	1.249
HCM Control Delay		14.8	15.1	236.2	11.6	127.6
HCM Lane LOS		B	C	F	B	F
HCM 95th-tile Q		0.6	1.6	34.8	0.2	20.3

**Intersection**

Intersection Delay, s/veh95.2

Intersection LOS F

Movement	EBL	EBT	EBR	WBL	WBT	WBR	NBL	NBT	NBR	SBL	SBT	SBR
Lane Configurations												
Traffic Vol, veh/h	142	472	42	10	354	9	21	166	52	9	74	136
Future Vol, veh/h	142	472	42	10	354	9	21	166	52	9	74	136
Peak Hour Factor	0.85	0.85	0.85	0.85	0.85	0.85	0.85	0.85	0.85	0.85	0.85	0.85
Heavy Vehicles, %	2	2	2	2	2	2	2	2	2	2	2	2
Mvmt Flow	167	555	49	12	416	11	25	195	61	11	87	160
Number of Lanes	1	1	0	0	1	0	0	1	0	0	1	1

Approach	EB	WB	NB	SB
Opposing Approach	WB	EB	SB	NB
Opposing Lanes	1	2	2	1
Conflicting Approach Left SB		NB	EB	WB
Conflicting Lanes Left	2	1	2	1
Conflicting Approach Right NB		SB	WB	EB
Conflicting Lanes Right	1	2	1	2
HCM Control Delay	156.9	74.1	31.1	16.4
HCM LOS	F	F	D	C

Lane	NBLn1	EBLn1	EBLn2	WBLn1	SBLn1	SBLn2
Vol Left, %	9%	100%	0%	3%	11%	0%
Vol Thru, %	69%	0%	92%	95%	89%	0%
Vol Right, %	22%	0%	8%	2%	0%	100%
Sign Control	Stop	Stop	Stop	Stop	Stop	Stop
Traffic Vol by Lane	239	142	514	373	83	136
LT Vol	21	142	0	10	9	0
Through Vol	166	0	472	354	74	0
RT Vol	52	0	42	9	0	136
Lane Flow Rate	281	167	605	439	98	160
Geometry Grp	6	7	7	6	7	7
Degree of Util (X)	0.689	0.4	1.351	0.998	0.247	0.371
Departure Headway (Hd)	9.523	8.62	8.043	8.771	9.78	8.989
Convergence, Y/N	Yes	Yes	Yes	Yes	Yes	Yes
Cap	382	416	454	417	369	403
Service Time	7.523	6.396	5.82	6.771	7.48	6.689
HCM Lane V/C Ratio	0.736	0.401	1.333	1.053	0.266	0.397
HCM Control Delay	31.1	17.1	195.5	74.1	15.7	16.9
HCM Lane LOS	D	C	F	F	C	C
HCM 95th-tile Q	5	1.9	27.6	12.3	1	1.7

HCM 6th TWSC  
 12: Prospect Av & BCHD North Driveway

02/22/2021

Intersection						
Int Delay, s/veh	0.2					
Movement	WBL	WBR	NBT	NBR	SBL	SBT
Lane Configurations		↗	↕			↕
Traffic Vol, veh/h	0	22	1148	7	0	905
Future Vol, veh/h	0	22	1148	7	0	905
Conflicting Peds, #/hr	0	0	0	0	0	0
Sign Control	Stop	Stop	Free	Free	Free	Free
RT Channelized	-	None	-	None	-	None
Storage Length	-	0	-	-	-	-
Veh in Median Storage, #	0	-	0	-	-	0
Grade, %	0	-	0	-	-	0
Peak Hour Factor	85	85	85	85	85	85
Heavy Vehicles, %	2	2	2	2	2	2
Mvmt Flow	0	26	1351	8	0	1065

Major/Minor	Minor1	Major1	Major2			
Conflicting Flow All	-	680	0	0	-	-
Stage 1	-	-	-	-	-	-
Stage 2	-	-	-	-	-	-
Critical Hdwy	-	6.94	-	-	-	-
Critical Hdwy Stg 1	-	-	-	-	-	-
Critical Hdwy Stg 2	-	-	-	-	-	-
Follow-up Hdwy	-	3.32	-	-	-	-
Pot Cap-1 Maneuver	0	393	-	-	0	-
Stage 1	0	-	-	-	0	-
Stage 2	0	-	-	-	0	-
Platoon blocked, %			-	-		-
Mov Cap-1 Maneuver	-	393	-	-	-	-
Mov Cap-2 Maneuver	-	-	-	-	-	-
Stage 1	-	-	-	-	-	-
Stage 2	-	-	-	-	-	-

Approach	WB	NB	SB
HCM Control Delay, s	14.8	0	0
HCM LOS	B		

Minor Lane/Major Mvmt	NBT	NBRWBLn1	SBT
Capacity (veh/h)	-	-	393
HCM Lane V/C Ratio	-	-	0.066
HCM Control Delay (s)	-	-	14.8
HCM Lane LOS	-	-	B
HCM 95th %tile Q(veh)	-	-	0.2



HCM 6th TWSC  
 14: BCHD South Driveway & Prospect Av

02/22/2021

Intersection						
Int Delay, s/veh	0.1					
Movement	WBL	WBR	NBT	NBR	SBL	SBT
Lane Configurations		↗	↕			↕
Traffic Vol, veh/h	0	17	1168	91	0	850
Future Vol, veh/h	0	17	1168	91	0	850
Conflicting Peds, #/hr	0	0	0	0	0	0
Sign Control	Stop	Stop	Free	Free	Free	Free
RT Channelized	-	None	-	None	-	None
Storage Length	-	0	-	-	-	-
Veh in Median Storage, #	0	-	0	-	-	0
Grade, %	0	-	0	-	-	0
Peak Hour Factor	85	85	85	85	85	85
Heavy Vehicles, %	2	2	2	2	2	2
Mvmt Flow	0	20	1374	107	0	1000

Major/Minor	Minor1	Major1	Major2			
Conflicting Flow All	-	741	0	0	-	-
Stage 1	-	-	-	-	-	-
Stage 2	-	-	-	-	-	-
Critical Hdwy	-	6.94	-	-	-	-
Critical Hdwy Stg 1	-	-	-	-	-	-
Critical Hdwy Stg 2	-	-	-	-	-	-
Follow-up Hdwy	-	3.32	-	-	-	-
Pot Cap-1 Maneuver	0	359	-	-	0	-
Stage 1	0	-	-	-	0	-
Stage 2	0	-	-	-	0	-
Platoon blocked, %			-	-		-
Mov Cap-1 Maneuver	-	359	-	-	-	-
Mov Cap-2 Maneuver	-	-	-	-	-	-
Stage 1	-	-	-	-	-	-
Stage 2	-	-	-	-	-	-

Approach	WB	NB	SB
HCM Control Delay, s	15.6	0	0
HCM LOS	C		

Minor Lane/Major Mvmt	NBT	NBRWBLn1	SBT
Capacity (veh/h)	-	-	359
HCM Lane V/C Ratio	-	-	0.056
HCM Control Delay (s)	-	-	15.6
HCM Lane LOS	-	-	C
HCM 95th %tile Q(veh)	-	-	0.2

Intersection						
Int Delay, s/veh	6.8					
Movement	EBL	EBT	WBT	WBR	SBL	SBR
Lane Configurations	↘	↑↑	↑↑		↘	↘
Traffic Vol, veh/h	53	613	768	112	68	47
Future Vol, veh/h	53	613	768	112	68	47
Conflicting Peds, #/hr	0	0	0	0	0	0
Sign Control	Free	Free	Free	Free	Stop	Stop
RT Channelized	-	None	-	None	-	None
Storage Length	100	-	-	-	0	50
Veh in Median Storage, #	-	0	0	-	0	-
Grade, %	-	0	0	-	0	-
Peak Hour Factor	80	80	80	80	80	80
Heavy Vehicles, %	2	2	2	2	2	2
Mvmt Flow	66	766	960	140	85	59

Major/Minor	Major1	Major2	Minor2		
Conflicting Flow All	1100	0	-	0	1545 550
Stage 1	-	-	-	-	1030 -
Stage 2	-	-	-	-	515 -
Critical Hdwy	4.14	-	-	-	6.84 6.94
Critical Hdwy Stg 1	-	-	-	-	5.84 -
Critical Hdwy Stg 2	-	-	-	-	5.84 -
Follow-up Hdwy	2.22	-	-	-	3.52 3.32
Pot Cap-1 Maneuver	630	-	-	-	105 479
Stage 1	-	-	-	-	305 -
Stage 2	-	-	-	-	565 -
Platoon blocked, %		-	-	-	
Mov Cap-1 Maneuver	630	-	-	-	94 479
Mov Cap-2 Maneuver	-	-	-	-	94 -
Stage 1	-	-	-	-	273 -
Stage 2	-	-	-	-	565 -

Approach	EB	WB	SB
HCM Control Delay, s	0.9	0	93.3
HCM LOS			F

Minor Lane/Major Mvmt	EBL	EBT	WBT	WBR	SBLn1	SBLn2
Capacity (veh/h)	630	-	-	-	94	479
HCM Lane V/C Ratio	0.105	-	-	-	0.904	0.123
HCM Control Delay (s)	11.4	-	-	-	148.4	13.6
HCM Lane LOS	B	-	-	-	F	B
HCM 95th %tile Q(veh)	0.4	-	-	-	5.1	0.4

HCM 6th AWSC  
3: Flagler Ln & Anita St/190th St

02/26/2021

Intersection	
Intersection Delay, s/veh	80.9
Intersection LOS	F

Movement	EBL	EBT	EBR	WBL	WBT	WBR	NBL	NBT	NBR	SBL	SBT	SBR
Lane Configurations		↔↔			↔↔		↗	↑	↗		↖	↖
Traffic Vol, veh/h	80	597	23	41	591	0	26	140	47	136	162	126
Future Vol, veh/h	80	597	23	41	591	0	26	140	47	136	162	126
Peak Hour Factor	0.95	0.95	0.95	0.95	0.95	0.95	0.95	0.95	0.95	0.95	0.95	0.95
Heavy Vehicles, %	2	2	2	2	2	2	2	2	2	2	2	2
Mvmt Flow	84	628	24	43	622	0	27	147	49	143	171	133
Number of Lanes	0	2	0	0	2	0	1	1	1	0	1	1

Approach	EB	WB	NB	SB
Opposing Approach	WB	EB	SB	NB
Opposing Lanes	2	2	2	3
Conflicting Approach Left	SB	NB	EB	WB
Conflicting Lanes Left	2	3	2	2
Conflicting Approach Right	NB	SB	WB	EB
Conflicting Lanes Right	3	2	2	2
HCM Control Delay	96.5	100.5	22.5	55.4
HCM LOS	F	F	C	F

Lane	NBLn1	NBLn2	NBLn3	EBLn1	EBLn2	WBLn1	WBLn2	SBLn1	SBLn2
Vol Left, %	100%	0%	0%	21%	0%	17%	0%	46%	0%
Vol Thru, %	0%	100%	0%	79%	93%	83%	100%	54%	0%
Vol Right, %	0%	0%	100%	0%	7%	0%	0%	0%	100%
Sign Control	Stop	Stop	Stop	Stop	Stop	Stop	Stop	Stop	Stop
Traffic Vol by Lane	26	140	47	379	322	238	394	298	126
LT Vol	26	0	0	80	0	41	0	136	0
Through Vol	0	140	0	299	299	197	394	162	0
RT Vol	0	0	47	0	23	0	0	0	126
Lane Flow Rate	27	147	49	398	338	251	415	314	133
Geometry Grp	8	8	8	8	8	8	8	8	8
Degree of Util (X)	0.092	0.477	0.151	1.127	0.944	0.719	1.181	0.937	0.362
Departure Headway (Hd)	12.836	12.308	11.569	10.592	10.43	10.654	10.565	11.427	10.45
Convergence, Y/N	Yes	Yes	Yes	Yes	Yes	Yes	Yes	Yes	Yes
Cap	281	295	312	347	349	341	348	320	346
Service Time	10.536	10.008	9.269	8.292	8.13	8.354	8.265	9.127	8.15
HCM Lane V/C Ratio	0.096	0.498	0.157	1.147	0.968	0.736	1.193	0.981	0.384
HCM Control Delay	16.8	25.7	16.3	120.5	68.3	36.4	139.3	70.8	19
HCM Lane LOS	C	D	C	F	F	E	F	F	C
HCM 95th-tile Q	0.3	2.4	0.5	15	9.9	5.3	16.7	9.4	1.6

Intersection

Intersection Delay, s/veh68.1

Intersection LOS F

Movement	EBL	EBT	EBR	WBL	WBT	WBR	NBL	NBT	NBR	SBL	SBT	SBR
Lane Configurations	↖	↗		↖	↗			↕			↕	
Traffic Vol, veh/h	91	584	23	53	451	27	38	32	59	21	24	123
Future Vol, veh/h	91	584	23	53	451	27	38	32	59	21	24	123
Peak Hour Factor	0.95	0.95	0.95	0.95	0.95	0.95	0.95	0.95	0.95	0.95	0.95	0.95
Heavy Vehicles, %	2	2	2	2	2	2	2	2	2	2	2	2
Mvmt Flow	96	615	24	56	475	28	40	34	62	22	25	129
Number of Lanes	1	1	0	1	1	0	0	1	0	0	1	0

Approach	EB	WB	NB	SB
Opposing Approach	WB	EB	SB	NB
Opposing Lanes	2	2	1	1
Conflicting Approach Left SB		NB	EB	WB
Conflicting Lanes Left	1	1	2	2
Conflicting Approach Right NB		SB	WB	EB
Conflicting Lanes Right	1	1	2	2
HCM Control Delay	107.1	46.8	14.2	14.7
HCM LOS	F	E	B	B

Lane	NBLn1	EBLn1	EBLn2	WBLn1	WBLn2	SBLn1
Vol Left, %	29%	100%	0%	100%	0%	12%
Vol Thru, %	25%	0%	96%	0%	94%	14%
Vol Right, %	46%	0%	4%	0%	6%	73%
Sign Control	Stop	Stop	Stop	Stop	Stop	Stop
Traffic Vol by Lane	129	91	607	53	478	168
LT Vol	38	91	0	53	0	21
Through Vol	32	0	584	0	451	24
RT Vol	59	0	23	0	27	123
Lane Flow Rate	136	96	639	56	503	177
Geometry Grp	2	7	7	7	7	2
Degree of Util (X)	0.284	0.191	1.178	0.112	0.932	0.353
Departure Headway (Hd)	8.028	7.177	6.638	7.556	7.002	7.628
Convergence, Y/N	Yes	Yes	Yes	Yes	Yes	Yes
Cap	451	497	543	478	523	474
Service Time	6.028	4.968	4.429	5.256	4.702	5.628
HCM Lane V/C Ratio	0.302	0.193	1.177	0.117	0.962	0.373
HCM Control Delay	14.2	11.7	121.4	11.2	50.7	14.7
HCM Lane LOS	B	B	F	B	F	B
HCM 95th-tile Q	1.2	0.7	22.4	0.4	11.4	1.6

Intersection

Intersection Delay, s/veh 50.9

Intersection LOS F

Movement	EBL	EBT	EBR	WBL	WBT	WBR	NBL	NBT	NBR	SBL	SBT	SBR
Lane Configurations												
Traffic Vol, veh/h	114	522	59	19	395	10	29	45	21	23	81	94
Future Vol, veh/h	114	522	59	19	395	10	29	45	21	23	81	94
Peak Hour Factor	0.95	0.95	0.95	0.95	0.95	0.95	0.95	0.95	0.95	0.95	0.95	0.95
Heavy Vehicles, %	2	2	2	2	2	2	2	2	2	2	2	2
Mvmt Flow	120	549	62	20	416	11	31	47	22	24	85	99
Number of Lanes	1	1	0	0	1	0	0	1	0	0	1	1

Approach	EB	WB	NB	SB
Opposing Approach	WB	EB	SB	NB
Opposing Lanes	1	2	2	1
Conflicting Approach Left SB		NB	EB	WB
Conflicting Lanes Left	2	1	2	1
Conflicting Approach Right NB		SB	WB	EB
Conflicting Lanes Right	1	2	1	2
HCM Control Delay	75.8	36	14.1	12.9
HCM LOS	F	E	B	B

Lane	NBLn1	EBLn1	EBLn2	WBLn1	SBLn1	SBLn2
Vol Left, %		31%	100%	0%	4%	22%
Vol Thru, %		47%	0%	90%	93%	78%
Vol Right, %		22%	0%	10%	2%	0%
Sign Control		Stop	Stop	Stop	Stop	Stop
Traffic Vol by Lane		95	114	581	424	104
LT Vol		29	114	0	19	23
Through Vol		45	0	522	395	81
RT Vol		21	0	59	10	0
Lane Flow Rate		100	120	612	446	109
Geometry Grp		6	7	7	6	7
Degree of Util (X)		0.228	0.233	1.087	0.835	0.243
Departure Headway (Hd)		8.598	6.984	6.401	6.964	8.314
Convergence, Y/N		Yes	Yes	Yes	Yes	Yes
Cap		420	512	563	522	435
Service Time		6.598	4.758	4.175	4.964	6.014
HCM Lane V/C Ratio		0.238	0.234	1.087	0.854	0.251
HCM Control Delay		14.1	11.9	88.3	36	13.7
HCM Lane LOS		B	B	F	E	B
HCM 95th-tile Q		0.9	0.9	18.4	8.5	0.9

HCM 6th TWSC  
 12: Prospect Av & BCHD North Driveway

02/26/2021

Intersection						
Int Delay, s/veh	0.4					
Movement	WBL	WBR	NBT	NBR	SBL	SBT
Lane Configurations		↗	↕			↕
Traffic Vol, veh/h	0	58	908	0	0	1073
Future Vol, veh/h	0	58	908	0	0	1073
Conflicting Peds, #/hr	0	0	0	0	0	0
Sign Control	Stop	Stop	Free	Free	Free	Free
RT Channelized	-	None	-	None	-	None
Storage Length	-	0	-	-	-	-
Veh in Median Storage, #	0	-	0	-	-	0
Grade, %	0	-	0	-	-	0
Peak Hour Factor	95	95	95	95	95	95
Heavy Vehicles, %	2	2	2	2	2	2
Mvmt Flow	0	61	956	0	0	1129

Major/Minor	Minor1	Major1	Major2		
Conflicting Flow All	-	478	0	0	-
Stage 1	-	-	-	-	-
Stage 2	-	-	-	-	-
Critical Hdwy	-	6.94	-	-	-
Critical Hdwy Stg 1	-	-	-	-	-
Critical Hdwy Stg 2	-	-	-	-	-
Follow-up Hdwy	-	3.32	-	-	-
Pot Cap-1 Maneuver	0	534	-	-	0
Stage 1	0	-	-	-	0
Stage 2	0	-	-	-	0
Platoon blocked, %					
Mov Cap-1 Maneuver	-	534	-	-	-
Mov Cap-2 Maneuver	-	-	-	-	-
Stage 1	-	-	-	-	-
Stage 2	-	-	-	-	-

Approach	WB	NB	SB
HCM Control Delay, s	12.6	0	0
HCM LOS	B		

Minor Lane/Major Mvmt	NBT	NBRWBLn1	SBT
Capacity (veh/h)	-	-	534
HCM Lane V/C Ratio	-	-	0.114
HCM Control Delay (s)	-	-	12.6
HCM Lane LOS	-	-	B
HCM 95th %tile Q(veh)	-	-	0.4

HCM 6th TWSC  
 14: BCHD South Driveway & Prospect Av

02/26/2021

Intersection						
Int Delay, s/veh	0.3					
Movement	WBL	WBR	NBT	NBR	SBL	SBT
Lane Configurations		↗	↕			↕
Traffic Vol, veh/h	0	44	779	38	0	1155
Future Vol, veh/h	0	44	779	38	0	1155
Conflicting Peds, #/hr	0	0	0	0	0	0
Sign Control	Stop	Stop	Free	Free	Free	Free
RT Channelized	-	None	-	None	-	None
Storage Length	-	0	-	-	-	-
Veh in Median Storage, #	0	-	0	-	-	0
Grade, %	0	-	0	-	-	0
Peak Hour Factor	95	95	95	95	95	95
Heavy Vehicles, %	2	2	2	2	2	2
Mvmt Flow	0	46	820	40	0	1216

Major/Minor	Minor1	Major1	Major2		
Conflicting Flow All	-	430	0	0	-
Stage 1	-	-	-	-	-
Stage 2	-	-	-	-	-
Critical Hdwy	-	6.94	-	-	-
Critical Hdwy Stg 1	-	-	-	-	-
Critical Hdwy Stg 2	-	-	-	-	-
Follow-up Hdwy	-	3.32	-	-	-
Pot Cap-1 Maneuver	0	573	-	-	0
Stage 1	0	-	-	-	0
Stage 2	0	-	-	-	0
Platoon blocked, %			-	-	-
Mov Cap-1 Maneuver	-	573	-	-	-
Mov Cap-2 Maneuver	-	-	-	-	-
Stage 1	-	-	-	-	-
Stage 2	-	-	-	-	-

Approach	WB	NB	SB
HCM Control Delay, s	11.8	0	0
HCM LOS	B		

Minor Lane/Major Mvmt	NBT	NBRWBLn1	SBT
Capacity (veh/h)	-	-	573
HCM Lane V/C Ratio	-	-	0.081
HCM Control Delay (s)	-	-	11.8
HCM Lane LOS	-	-	B
HCM 95th %tile Q(veh)	-	-	0.3

Intersection						
Int Delay, s/veh	3.3					
Movement	EBL	EBT	WBT	WBR	SBL	SBR
Lane Configurations	↖	↑↑	↑↑		↖	↖
Traffic Vol, veh/h	16	659	717	101	97	23
Future Vol, veh/h	16	659	717	101	97	23
Conflicting Peds, #/hr	0	0	0	0	0	0
Sign Control	Free	Free	Free	Free	Stop	Stop
RT Channelized	-	None	-	None	-	None
Storage Length	100	-	-	-	0	50
Veh in Median Storage, #	-	0	0	-	0	-
Grade, %	-	0	0	-	0	-
Peak Hour Factor	95	95	95	95	95	95
Heavy Vehicles, %	2	2	2	2	2	2
Mvmt Flow	17	694	755	106	102	24

Major/Minor	Major1	Major2	Minor2		
Conflicting Flow All	861	0	-	0	1189 431
Stage 1	-	-	-	-	808 -
Stage 2	-	-	-	-	381 -
Critical Hdwy	4.14	-	-	-	6.84 6.94
Critical Hdwy Stg 1	-	-	-	-	5.84 -
Critical Hdwy Stg 2	-	-	-	-	5.84 -
Follow-up Hdwy	2.22	-	-	-	3.52 3.32
Pot Cap-1 Maneuver	776	-	-	-	181 573
Stage 1	-	-	-	-	399 -
Stage 2	-	-	-	-	660 -
Platoon blocked, %		-	-	-	
Mov Cap-1 Maneuver	776	-	-	-	177 573
Mov Cap-2 Maneuver	-	-	-	-	177 -
Stage 1	-	-	-	-	390 -
Stage 2	-	-	-	-	660 -

Approach	EB	WB	SB
HCM Control Delay, s	0.2	0	42.6
HCM LOS			E

Minor Lane/Major Mvmt	EBL	EBT	WBT	WBR	SBLn1	SBLn2
Capacity (veh/h)	776	-	-	-	177	573
HCM Lane V/C Ratio	0.022	-	-	-	0.577	0.042
HCM Control Delay (s)	9.7	-	-	-	49.9	11.6
HCM Lane LOS	A	-	-	-	E	B
HCM 95th %tile Q(veh)	0.1	-	-	-	3.1	0.1